

**SMC 2410
VALVE AND PLUMBING KIT INSTRUCTIONS
CASE I.H.**

MODEL	2WD	4WD	LESS CAB	WITH CAB
595	X		X	
695	X		X	
895	X		X	

Valve and plumbing kit can be installed using tools ordinarily available. Valve control handle has been factory preassembled for ease of installation. Shut off engine and engage brakes during installation.

NOTE: Apply sealant only to all tapered threads unless coupled with swivel adapters. When using teflon tape, wrap tape clockwise (as viewed from end) and wrap only twice. Keep sealant away from first two threads of tapered end to prevent contamination of hydraulic fluid. Do not use sealant on o-ring or flare adapter threads.

ATTACHING VALVE AND STAND TO TRACTOR (Figure 2)

1. Fasten valve bracket (2) to right mid mounting bracket using 1/2 x 2-1/2 cap screws (15), 1/2 flat washers (17) and 1/2 lock nuts (16).
2. Fasten valve (1) to bracket (2) using 3/8 x 2 cap screws (6) and 3/8 lock nuts (7).
3. Making sure surface is clean and dry attach decal (14) to upper rear side of right loader upright.



WARNING: Escaping hydraulic fluid under pressure can penetrate skin causing serious injury.

- DO NOT use your hands to check for leaks. Use a piece of cardboard or paper to search for leaks.
- Stop engine and relieve pressure before connecting or disconnecting lines.
- Tighten all connections before starting engine or pressurizing lines.

If any fluid is injected into skin, obtain medical attention immediately or gangrene may result.

PLUMBING CONTROL VALVE TO TRACTOR HYDRAULICS (Figure 2)

1. Install hydraulic plumbing kit (94070C1)(must be ordered from Case IH dealer). Follow instructions provided in kit for proper installation.
2. Install 7/8 x 1-1/16 90° elbow fittings (3) into inlet and outlet ports of valve (1).

NOTE: Do not use fittings provided in kit (94070C1) from dealer.

Connect pressure hose from tractor hydraulics to pressure port in valve (1). Connect return hose from tractor hydraulics to return port in valve (1).

3. Route hoses down along valve bracket (2) and secure with adjustable strap (9).

PLUMBING LOADER TO CONTROL VALVE (Figures 1 & 2)

1. Install 7/8 x 1/2 NPT 45° elbow fittings (4) to working ports of valve (1). Install 1/2 NPTF x 1/2 NPSM adapter fittings (10) to 45° elbow fittings (4). Install 1/2 female couplers (5) to each adapter fitting (10). Install one of each colored spiral bands (12) to female couplers.
2. Install 3/8 x 130 hoses (13) onto boom oil line tubes. Install and tighten hose fittings one at a time from bottom oil line up. Loosening closest oil line clamp will ease installation. Install male couplers (11) to free ends of hoses (13).
3. Connect hoses from boom oil lines to female quick couplers on control valve as shown (Figures 1 & 2). Top hose (Base of Bucket Cylinder) to port "C", second from top hose (Rod end of Bucket Cylinder) to port "D", third from top hose (Rod end of Lift Cylinder) to Port "A" and bottom hose (Base of Lift Cylinder) to port "B". Install colored spiral bands (12) onto male couplers (11) to match colors on female quick couplers (5).

BUNDLE 2-6160

PLUMBING LOADER TO CONTROL VALVE (Continued) (Figures 1 & 2)

4. Wrap one end of rubber strap (8) around hoses and hook it into itself. Hook other end to front of yoke. Use two plastic tie straps (9) to secure hoses together.
5. Start engine and slowly cycle lift and bucket cylinders several times to purge air out of system, then retract cylinders and shut off tractor engine. Add additional tractor hydraulic fluid as specified in the tractor owners manual to bring level of hydraulic fluid up to full.

NOTE: When cycling loader, operate loader according to operation decal (14) on box. If direction of control lever is wrong, or loader will not lower, re-check connections shown.

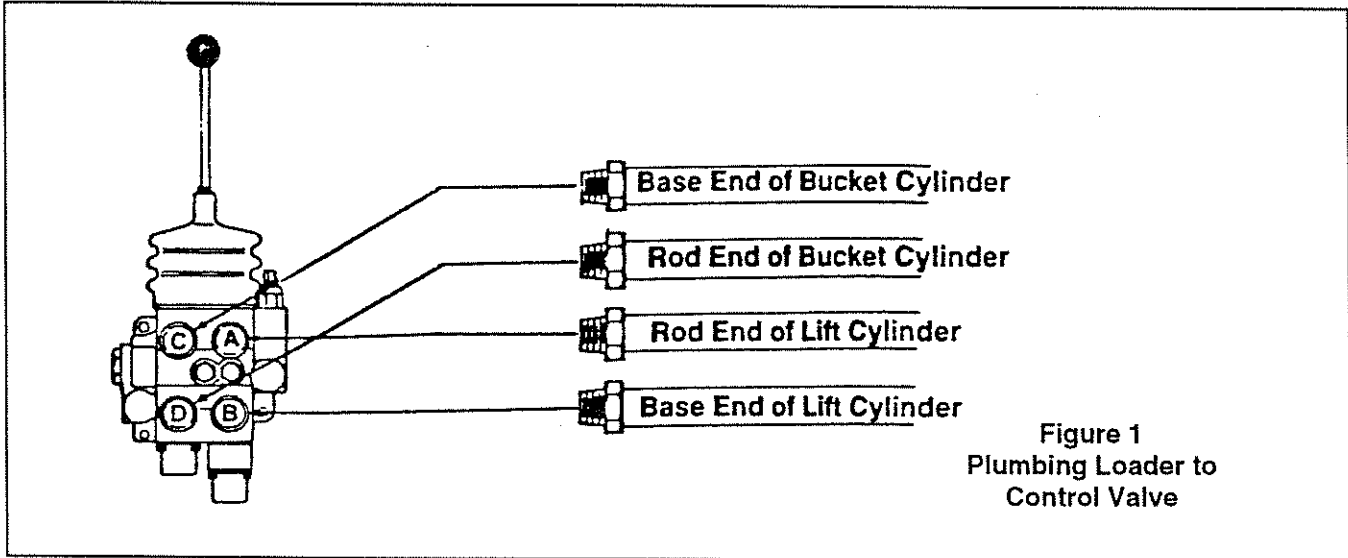

Figure 1
Plumbing Loader to
Control Valve

PARTS LIST - HYDRAULIC KIT

Item	Part No.	Description	Qty.
1	35904	VALVE, Prince, HC-V-K2 (Includes single control handle)	1
2	41705	BRACKET, Valve mounting	1
3	32845-4	FITTING, Elbow, 7/8-14 x 1 1/16-12 90°	2
4	8561-6	FITTING Adapter O-Ring 7/8-14 x 1/2 NPT 45°	4
5	6147-8	COUPLER, Female Quick attach 1/2-14	4
6	G180130	SCREW, Cap, 3/8-16 x 2	3
7	G9413534	NUT, Lock, 3/8-16	3
8	7438-1	STRAP, Rubber	1
9	8137-1	STRAP, Adjustable	3
10	6084-5	FITTING, Adapter, 1/2 NPTF x 1/2 NPSM	4
11	6137-6	COUPLER, Quick Attach, male 1/2-14	4
12	36240-9	BAND, Spiral, Blue	2
	36240-10	BAND, Spiral, Red	2
	36240-11	BAND, Spiral, Yellow	2
	36240-12	BAND, Spiral, Green	2
13	35623-2	HOSE, 3/8 x 130"	4
14	30797	DECAL, Joystick control	1
15	G180185	SCREW, Cap, 1/2-13 x 2-1/2	2
16	G9414074	NUT, Hex, Lock, 1/2	2
17	G120396	WASHER, Flat, 1/2	2

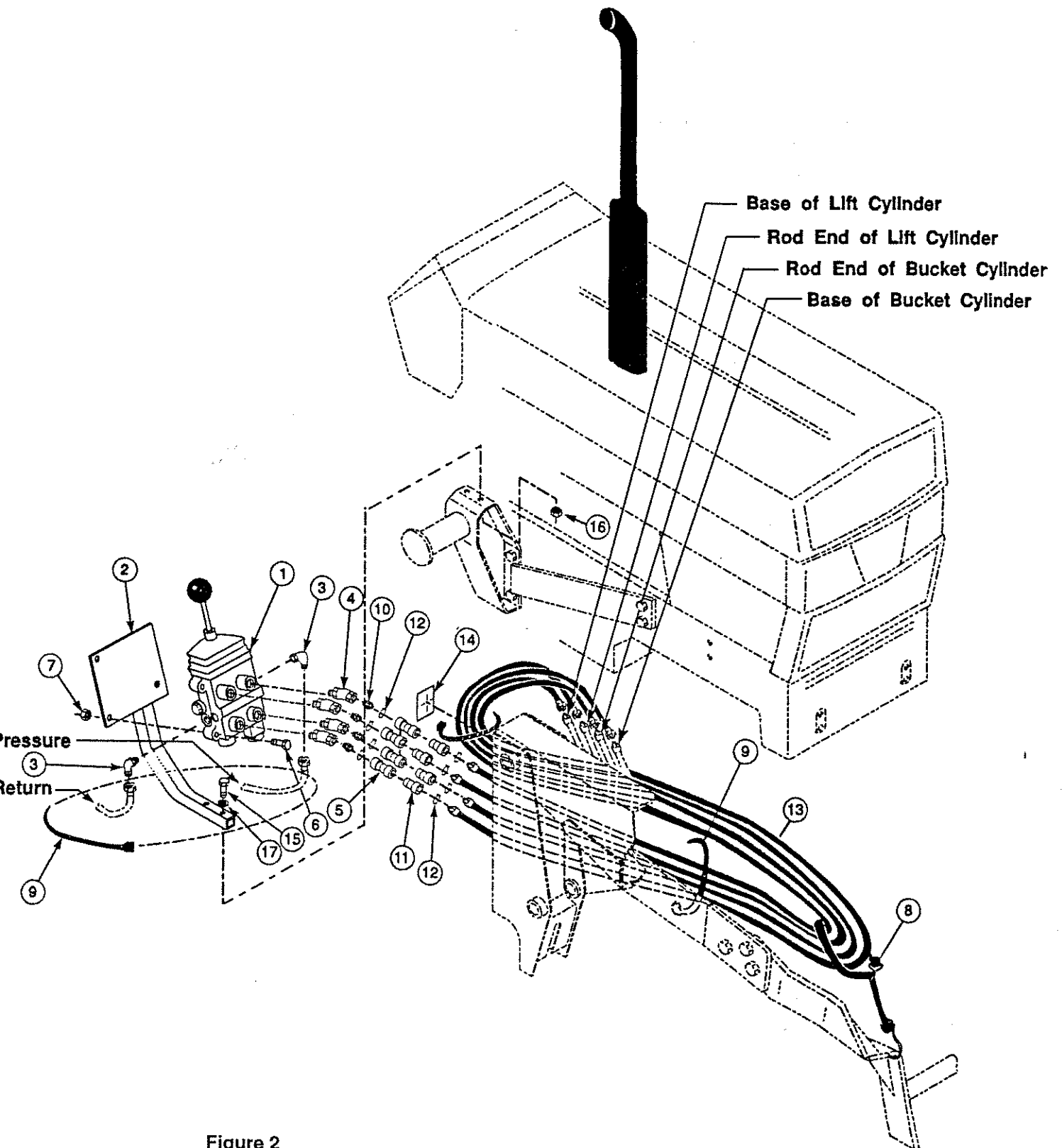

Figure 2
Plumbing Loader to Control
Valve and Tractor Hydraulics

BUNDLE 2-6160

PRINCE RD-5200 VALVE

The following is an outline of procedure for disassembling and reassembling valve.



WARNING: The valve has a valve relief setting pre-set at factory. Tampering with this setting can cause **SERIOUS INJURY** to operator and **DAMAGE** to tractor or loader. Unauthorized adjustments or service to valve relief will **VOID WARRANTY** of both loader and tractor. If adjustments or service to valve relief are required during warranty period, an authorized service department must be consulted for authorization.

NOTE: It is advisable to mark or tag all hoses and parts so they will be reinstalled in their proper location.

VALVE SPOOL SEAL REPLACEMENT

IMPORTANT: Replacement of spool seals is a delicate operation and must be carefully performed to prevent damage to new seals or scoring of spool bores. If spools or spool bores are scored or damaged in any way, complete valve must be replaced, because valve body and spools are not sold separately.

1. Slide molded bellows (53) off of retaining plate (46). Tap spring pins (43) out of spool adapters (42). Remove four screws (47) securing valve handle assembly to valve body (59).

2. Remove screws (38) and end cap (31) from valve body (59). Remove cap screws (37), washer (36), stop cup (35), centering spring (34), stop cup (33) and retainer plate (21) from valve spool.
3. Remove screws (32) and end cap (31) from valve body (59). Slowly remove float sleeve (30) while cupping hand around sleeve to catch detent balls (29) and springs (28). Remove detent retainer (27), retainer plate (26), float spacer (25), washer (24), centering spring (23), stop cup (22) and retainer plate (21) from valve spool.
4. Push spools into valve body (59) from rear until rear spool seals (20) and o-rings (19) are exposed. Remove seals and o-rings by using a wire hook and screwdriver. Push spools back into valve body from front until front spool seals and o-rings are exposed. Remove front spool seals and o-rings with wire hook and screwdriver.
5. Clean all parts in a suitable cleaning solvent and then use air pressure to blow any dirt or excess solvent from all parts. Examine all parts for wear or damage and replace if necessary.
6. Lubricate all o-rings and spools with oil to prevent **DAMAGE** when assembling.
7. Lubricate all detent and spring centering parts with a light coat of grease before assembling.
8. Reassemble all parts in reverse order of disassembly.

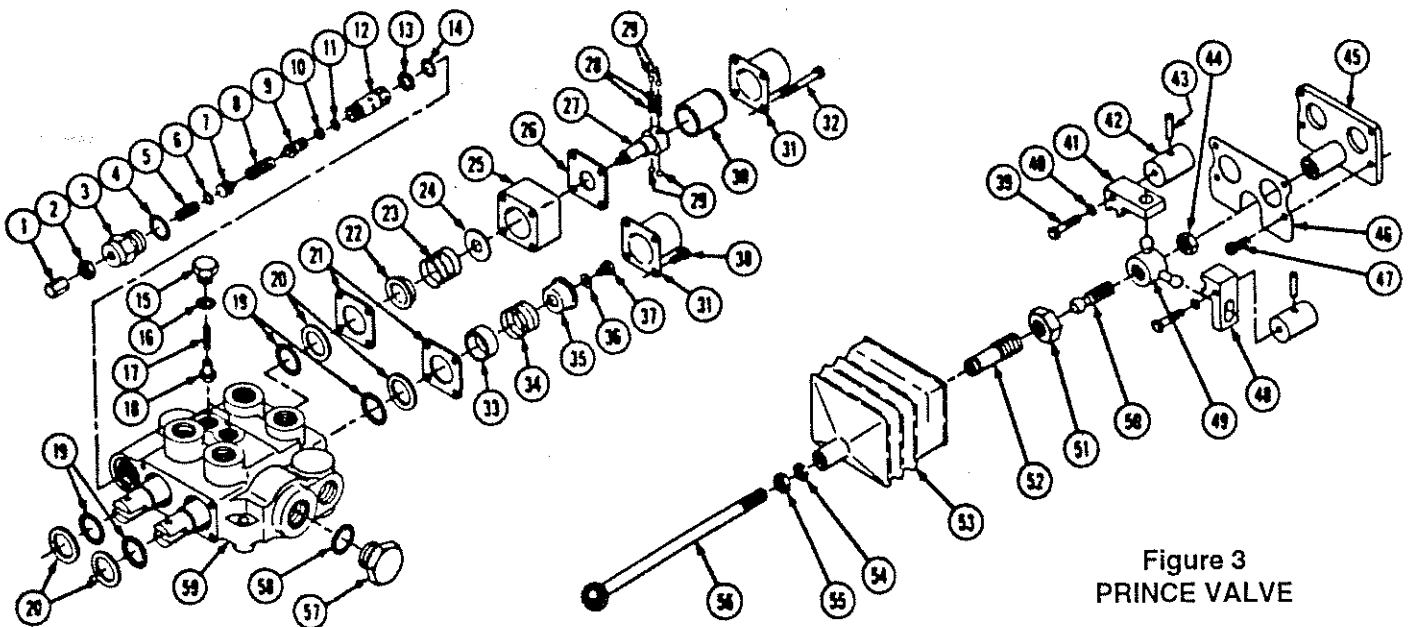

Figure 3
PRINCE VALVE

RELIEF VALVE

NOTE: *The relief valve and load check sections of control valve may be removed separately to clean, inspect or replace parts without removing valve spools.*

1. Remove retainer plug (3) from valve body. Unscrew relief cartridge (12) from retainer plug (3). Remove spring (8), spring retainer (7) and piston (9).



WARNING: *Do not remove or adjust acorn nut (1), jam nut (2) or set screw (5) on retainer plug (3).*

2. Remove o-ring (4) from retainer plug (3) and o-ring (6) from spring retainer (7). Remove o-ring (11) and backup (10) from piston (9). Remove o-ring (14) and backup (13) from relief cartridge (12).
3. Remove load check plugs (15), springs (17) and load check poppets (18). Remove o-rings (16) from load check plugs (15).
4. Clean all parts with a suitable solvent and then use air pressure to blow any dirt or excess solvent from all parts. Examine all parts for wear or damage and replace if necessary.
5. Lubricate all o-rings and seals with oil to prevent DAMAGE when assembling.
6. Reinstall load check poppets (18), springs (17), o-rings (16) and load check plugs (15) into top of valve body (59).
7. Install o-ring (4) onto retainer plug (3) and o-ring (6) onto spring retainer (7). Install backup (10) and o-ring (11) onto piston (9). Install backup (13) and o-ring (14) onto relief cartridge (12).
8. Install piston (9) and spring (8) into relief cartridge (12) and spring retainer (7) into retainer plug (3). Install relief cartridge into retainer plug and tighten to 10-20 ft.-lbs. of torque.
9. Install retainer plug (3) into valve body (59) and tighten.

SINGLE HANDLE CONTROL LEVER

1. Loosen nut (55) and unscrew handle (56). Remove molded bellows (53).
2. Loosen jam nut (51) and unscrew handle adapter (52) from center pivot (49).
3. Remove screws (39), lock washers (40) and slide blocks (41 & 48) from spool adapters 42).

4. Loosen jam nut (51) and unscrew handle adapter (52) from center pivot (49).
5. Clean all parts with a suitable cleaning solvent and then use air pressure to blow any dirt or excess solvent from all parts. Examine all parts for wear or damage and replace if necessary.
6. Grease ball and socket joints on slide blocks (41 & 48), center pivot (49), pivot stud (50) and handle adapter (52). Grease slot on slide block (48).
7. Fasten top slide block (41) to spool adapter (42) on relief side of valve with 1/4 x 1-1/2 cap screw (39) and lock washer (40). Fasten side slide block (48) to spool adapter (42) with 1/4 x 1-1/2 cap screw (39) and lock washer (40). Top slide block (41) must be in slot of side slide block (48).
8. Position center pivot (49) so spherical ends are in holes in slide blocks (41 & 48). Insert pivot stud (50) through center pivot (49) and install jam nut (44). Install pivot stud (50) into base plate (45) approximately one-half inch. Do not tighten jam nut (44).
9. Install jam nut (51) onto handle adapter (52). Install handle adapter (52) into center pivot (49) until contact is made with ball of pivot stud (50). Then turn handle adapter (52) out approximately 1/4 turn and tighten jam nut (51).

NOTE: *When installing handle into handle adapter and after securing jam nut, make sure valve is free to return to neutral position when activated.*



CAUTION: *Assembly of handle to adapter can cause handle adapter to press down on ball pivot causing linkage to stick in activated positions.*

10. Slide molded bellows (53) onto handle adapter (52). Install nut (55) and lock washer (54) onto handle (56). Install handle (56) into handle adapter (52) and lock with nut (55).
11. Adjust handle angle perpendicular to base plate (45) by turning pivot plate stud. Adjust with a standard screwdriver inserted in hole located on back side of base plate. After handle is adjusted, tighten jam nut (44).

NOTE: *Handle must return freely to neutral position from all working positions.*

12. Slide molded bellows (53) onto retaining plate (46).

BUNDLE 2-6160

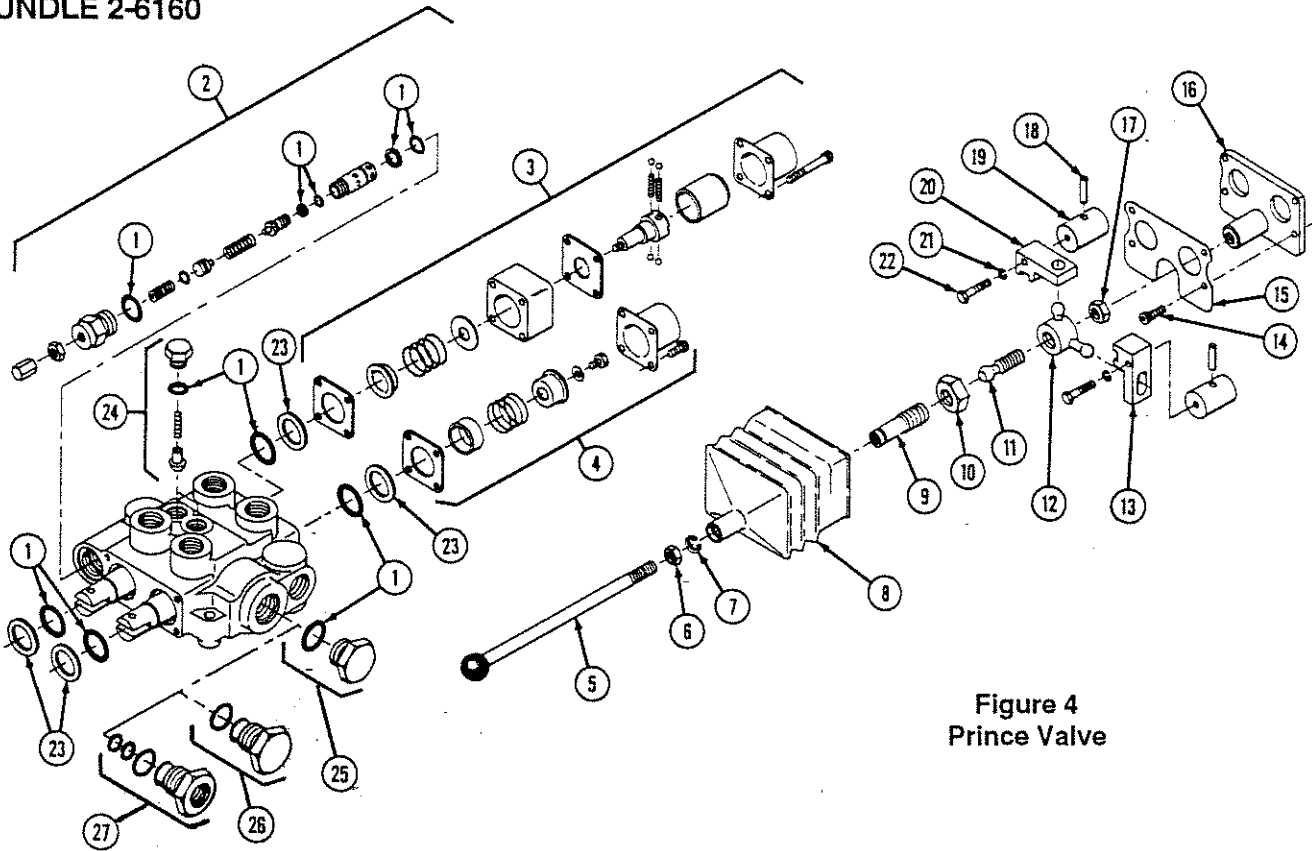

Figure 4
Prince Valve

PARTS LIST - PRINCE RD-5200 CONTROL VALVE, 35904

Item	Part No.	Description	Qty.
1	36071	REPAIR KIT, Seal	1
2	36072	REPAIR KIT, Relief Valve	1
3	36073	REPAIR KIT, Detent Spring Centering	1
4	36074	REPAIR KIT, Spring Centering	1
5	36075	HANDLE, Knob	1
	36076	REPLACEMENT, Handle Knob	1
6	G271506	NUT, Hex, 7/16-20	1
7	G120383	WASHER, Lock, 7/16	1
8	36077	BELLOWS, Molded	1
9	36078	ADAPTER, Handle	1
10	G427640	NUT, Jam, 3/4-16	1
11	36081	STUD, Pivot	1
12	36079	PIVOT, Center	1
13	36080	BLOCK, Side Slide	1
14	36082	SCREW, Hex Socket Head, 1/4-20 x 3/4	4
15	36083	PLATE, Retainer	1
16	36084	PLATE, Base	1
17	G124934	NUT, Jam, 1/2-20	1
18	G453670	PIN, Spring, 1/4 x 1-1/8	2
19	36085	ADAPTER, Spool	2
20	36086	BLOCK, Top Slide	1
21	G120380	WASHER, Lock, 1/4	2
22	G180034	SCREW, Cap, 1/4-20 x 1-1/2	2
23	36218	BACKUP, Spool Seal	4
24	36220	REPAIR KIT, Load Check	2
25	36219	PLUG, Open Center	1
26	38066	PLUG, Closed Center	1
27	38419	SLEEVE, Power Beyond	1