

# OPERATION AND ASSEMBLY MANUAL

Keep With Operator's Manual

## SMC & RHINO SSL COMPATIBLE BALE HUGGER

### CONTENTS

INTRODUCTION .....	1
OPERATION .....	1-2
ASSEMBLY.....	3
PARTS LIST .....	4-6
TORQUE SPECIFICATIONS .....	5
CYLINDER SERVICE .....	7
SAFETY DECALS.....	8

### INTRODUCTION

Bale hugger can be installed using tools ordinarily available.

A hydraulic third function kit is needed to operate bale hugger.

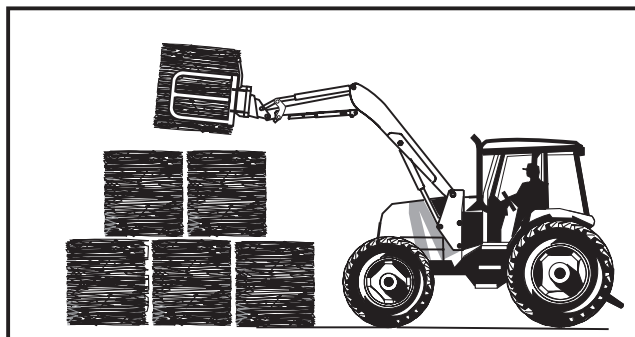

The bale hugger is designed to gently handle bales up to six feet in diameter without puncturing wrap. The bale hugger allows for easy on-end stacking of bales. By stacking bales on end the material in the bale is compressed and penetration of air and dampness is reduced.

### OPERATING BALE HUGGER

Be sure that your tractor is properly ballasted. Proper ballast should result in a minimum of 25% of the total weight of tractor, loader, and rated load on the rear wheels of tractor when attachment contains rated load and is in the maximum forward position.

Operation of your tractor and loader with bale hugger requires some same basic considerations as operation with a bucket, plus new requirements: you must operate a bale hugger while already operating your loader; and you must also take into account additional space re-

quirements (added length and height) needed because of attached bale hugger.

#### • GRASPING ROUND BALES

Although bales can be picked up many ways, the preferred method to grab a bale with the bale hugger is to grab around the round surface of the bale to provide maximum surface contact between the bale hugger and the bale.

Pick up the bale with the bottom tube of the bale hugger about 6" from the edge of the bale, see illustration below.

**NOTE:** *If the bale is very heavy and you are encountering difficulty rotating the bale up with the flat side parallel with the ground, you should open the bale hugger and move the tractor ahead slightly, regrasp the bale and rotate the bale so the flat surface of the bale is parallel with the ground. Set the bale on the ground and regrasp the bale allowing about 6" between the ground and the bottom tube on the bale hugger.*

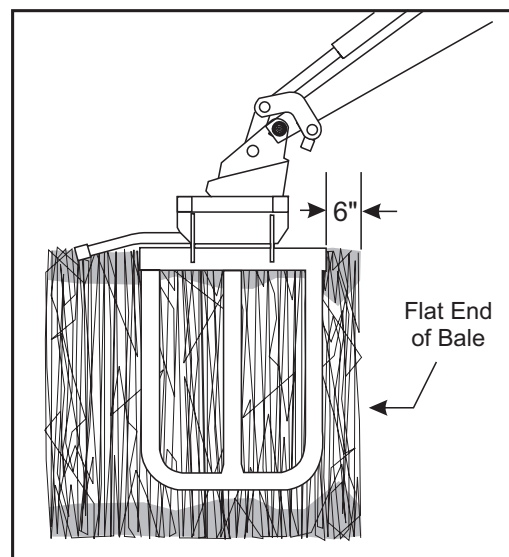

• **LIFTING AND CARRYING LOAD**

After grasping the bale lift and roll back the bale slightly.

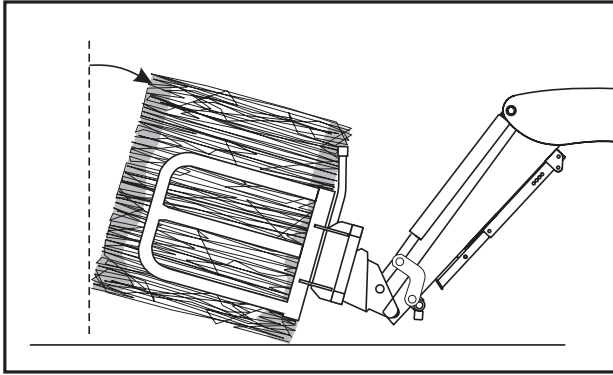

Position the loader low for maximum stability and visibility whether bale hugger is loaded or empty.

Use extreme care when operating loader on a slope. Carry load as low as possible. This keeps center of gravity for bale, tractor and loader low; helping to provide maximum tractor stability.

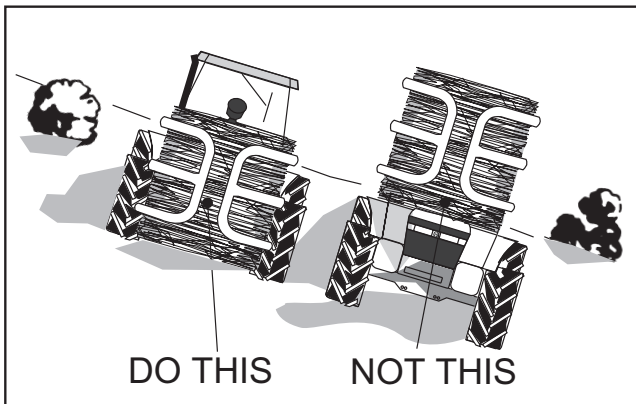

**CAUTION:** Operating a loader on a hillside is dangerous. Extreme care is recommended to avoid overturns.



**WARNING:** Keep bale hugger and loader boom clear of overhead lines. Allowing loader boom or any attachments to contact overhead power lines may electrify entire tractor and electrocute (kill) operator.

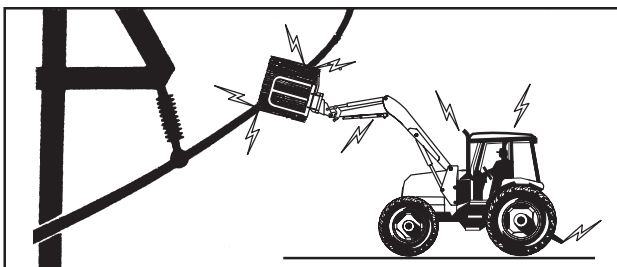

• **STACKING BALES**



**WARNING:** Because of size and weight of large bales, extreme care must be taken in handling them. Be aware of forces acting on stacked bales due to gravity and keep workers far from zones of potential hazard from shifting or falling bales. **DO NOT ALLOW BYSTANDERS!**

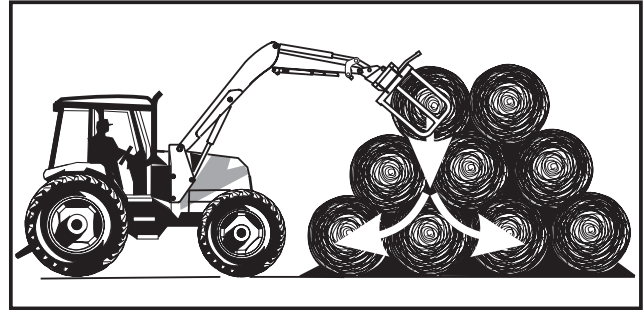

Use loader and bale hugger to gently position bale on stack. Slowly release pressure on bale hugger and back tractor and bale hugger away being careful not to upset bale.

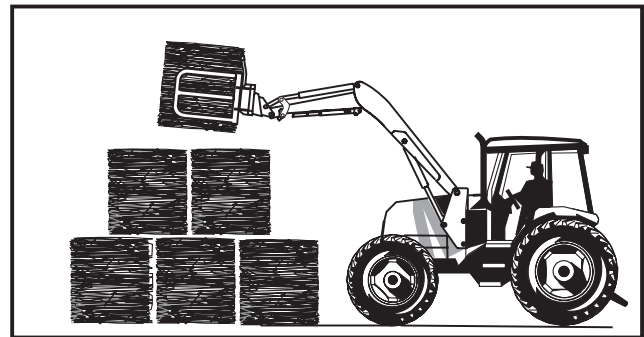

Stacking bales on end (flat side to flat side) allows the material in the bale to compress reducing penetration of air. If the bale is not wrapped, water penetration is reduced when the bales are stored with the rounded side toward the ground.

When unstacking bales, always remove the top bales on each row first and progress down to the lower bales.

**IMPORTANT:** The bale hugger is not designed to accommodate the forces capable of being generated by applying down pressure to either the loader lift or tilt cylinders with the frame of the bale hugger resting against an immovable object. Doing so can result in damage to the bale hugger.

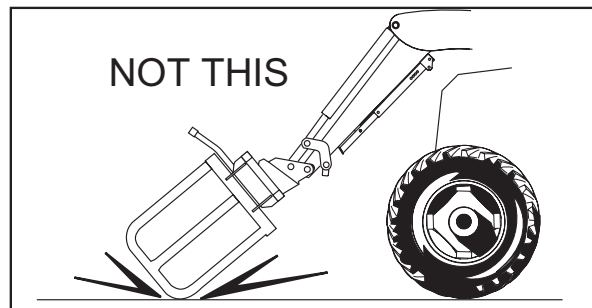

## ASSEMBLY

### • REMOVING BALE HUGGER FROM PALLET

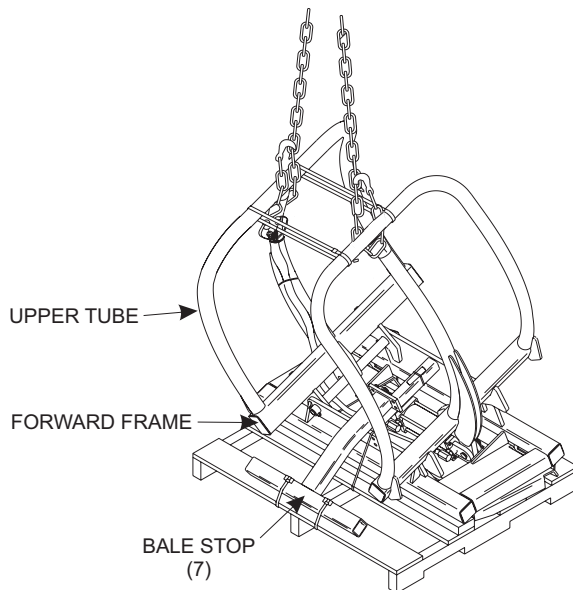

1. Cut banding securing bale stop (7) and remove from pallet. Remove parts bag.
2. Loop chain around upper tube on bale hugger forward frame. Cut banding securing bale hugger and lift with overhead hoist. Rotate down into mounting position.
3. Cut plastic ties securing bale hugger cylinder and hoses. Remove clevis pin from rod end of cylinder and attach cylinder to cylinder lug on right side forward frame.
4. Attach bale stop (7) to bale hugger using four 1/2 x 1-3/4 cap screws (8) and 1/2-13 lock nuts (9).



**DANGER:** Never operate bale hugger without bale stop in place. Operation without this guard in place could result in serious injury or death.

### • ATTACHING BALE HUGGER TO LOADER

No tools are needed to install bale hugger. Loader must be equipped with quick attach device (2-6599, 2-6683 or 2-7124).



**WARNING:** To avoid injury during attachment or detachment, do not allow bystanders within 10 feet of loader or attachment.

1. Locate tractor and attachment on level ground. Lower boom to rest on the ground. Extend the bucket

cylinders slightly, while raising the boom to provide three to five inches of ground clearance, drive the tractor ahead slowly toward the attachment, aligning the loader quick attach device.

2. While driving the tractor ahead slowly to maintain contact with the attachment, activate the lift cylinders to raise the loader until the quick attach engages under the attachment lip.
3. Then activate bucket cylinders to retract, continuing to roll the attachment back completely.
4. Place tractor in neutral, set parking brake, shut off tractor. Move latch pin handles to latch (down) position.
5. Connect hoses to third function kit on loader or skid loader. Rotate attachment making sure hoses are routed properly and do not become pinched or snagged by loader or skid loader parts. Fasten hoses securely so that they remain in correct position and do not drop down where they could be pinched or sheared. Rotate attachment to a slight downward angle so quick attach latch pins are visible. Visually inspect attachment mechanism to verify that pins are engaged through latch plate on back of attachment.

**NOTE:** If the attachment is not securely attached, follow the instructions for detaching it and repeat the above procedure.

### • DETACHING BALE HUGGER



**WARNING:** To avoid injury during installation of the loader attachment, do not allow bystanders within 10 feet of loader or attachment.

1. Locate tractor and loader on level ground.
2. Lower boom arms until the attachment is level and resting on ground.
3. Place tractor in neutral, set parking brake, shut off tractor engine and disengage quick attach device latch pins by moving handles to unlatch position.
4. Start tractor engine, release brake and extend bucket cylinders while slowly backing the tractor away from bale hugger, until quick attach disengages from attachment.

Figure 1  
Bale Hugger Assembly

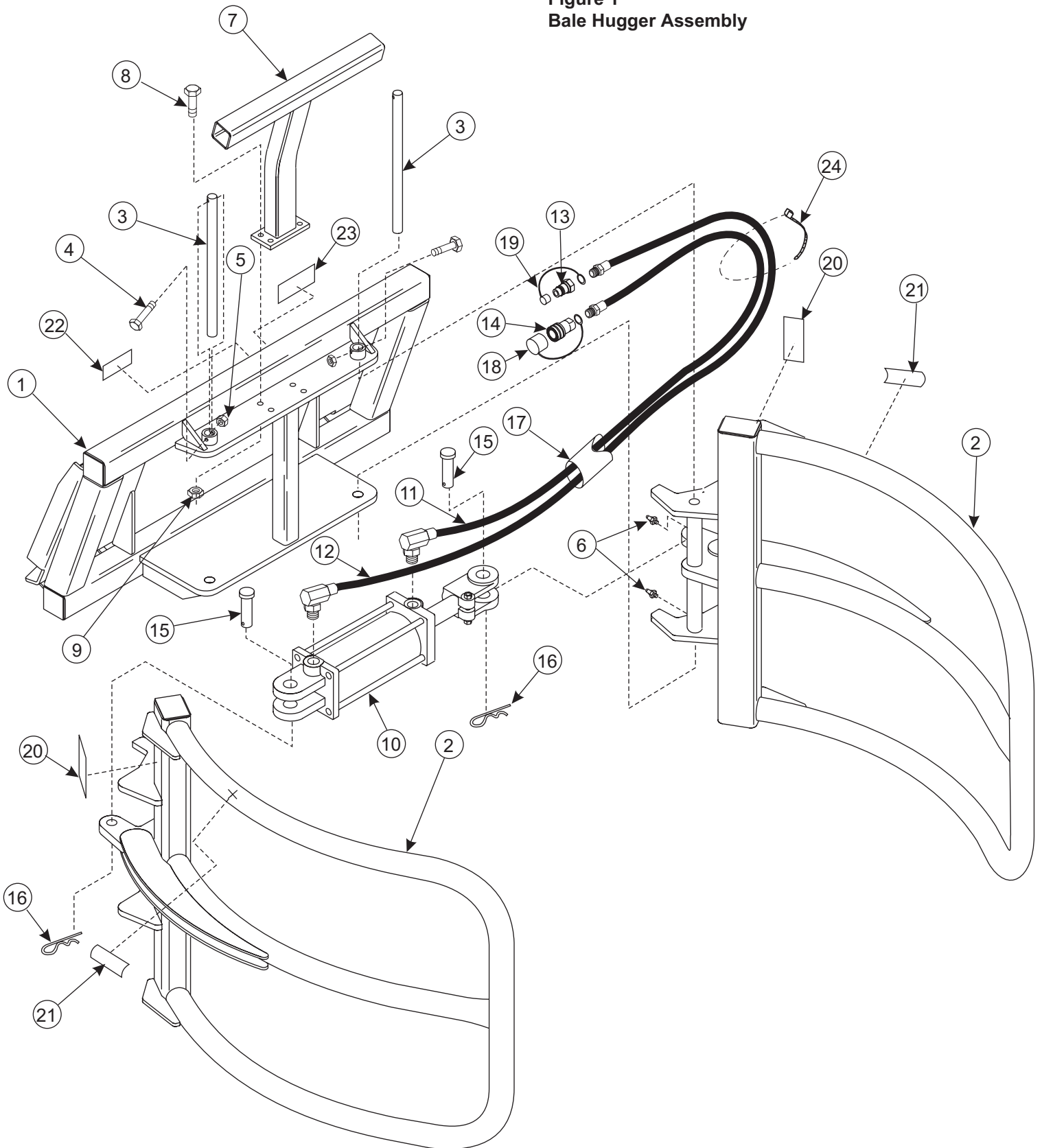

**PARTS LIST - BALE HUGGER (FIGURE 1)**

ITEM	PART NO.	DESCRIPTION	QTY.
1	49016	FRAME ASSEMBLY, Rear	1
2	48996	FRAME ASSEMBLY, Front	2
3	42409-2	PIN	2
4	41838-28	SCREW, Cap, 5/16-18 X 2	2
5	41840-2	NUT, Lock, 5/16 - 18	2
6	6075-4	GREASE FITTING, 1/4-28	4
7	48999	BALE STOP ASSEMBLY	1
8	41838-12	SCREW, Cap, 1/2-13 x 1-3/4	4
9	41840-5	NUT, Lock, 1/2-13	4
10	49041	CYLINDER ASSEMBLY	1
11	49020-1	HOSE, .375 I.D. X 48	1
12	49020-2	HOSE, .375 I.D. X 56	1
13	45292-2	COUPLER, Tip	1
14	45291-2	COUPLER, Body	1
15	41902-17	CLEVIS PIN	2
16	41903-3	COTTER PIN	2
17	34853-39	SLEEVE, NYLON	1
18	4838-15	DUST CAP	1
19	4838-16	DUST CAP	1
20	50527	DECAL, Caution	2
21	50528	DECAL, Warning	2
22	50529	DECAL, Capacity	1
23	50530	DECAL, Warning	1
24	8137-1	STRAP, Adjustable	3

**GENERAL TORQUE SPECIFICATIONS**

USE THE FOLLOWING TORQUES WHEN SPECIAL TORQUES ARE NOT GIVEN







AMERICAN STANDARD CAP SCREWS					METRIC CAP SCREWS														
SAE Grade		5			8			Metric Class		8.8				10.9					
										 				 					
Cap Screw		TORQUE				TORQUE				Cap Screw		TORQUE				TORQUE			
Size		FT-LBS		Nm		FT-LBS		Nm		Size		FT-LBS		Nm		FT-LBS		Nm	
Inches		MIN	MAX	MIN	MAX	MIN	MAX	MIN	MAX	Millimeters		MIN	MAX	MIN	MAX	MIN	MAX	MIN	MAX
1/4-20		6.25	7.25	8.5	10	8.25	9.5	11	13	M6x100		6	8	8	11	9	11	12	15
1/4-28		8	9	11	12	10.5	12	14	16	M8 x 1.25		16	20	215	27	23	27	31	36.5
5/16 - 18		14	15	19	20	18.5	20	25	27	M10 x 1.50		29	35	39	47	42	52	57	70
5/16 - 24		17.5	19	23	26	23	25	31	34	M12 x 1.75		52	62	70	84	75	91	102	123
3/8 - 16		26	28	35	38	35	37	47.5	50	M14 x 2.00		85	103	115	139	120	146	163	198
3/8 - 24		31	34	42	46	41	45	55.5	61	M16 x 2.50		130	158	176	214	176	216	238	293
7/16 - 14		41	45	555	61	55	60	74.5	81	M18 x 2.50		172	210	233	284	240	294	325	398
7/16 - 20		51	55	69	745	68	75	92	102	M20 x 2.50		247	301	335	408	343	426	465	577
1/2 - 13		65	72	88	975	86	96	116	130	M22 x 2.50		332	404	450	547	472	576	639	780
1/2 - 20		76	84	103	114	102	112	138	152	MM24 x 3.00		423	517	573	700	599	732	812	992
9/16 - 12		95	105	129	142	127	140	172	190	M27 x 3.00		637	779	863	1055	898	1098	1217	1488
9/16 - 18		111	123	150	167	148	164	200	222	M30 x 3.00		872	1066	1181	1444	1224	1496	1658	2027
5/8 - 11		126	139	171	188	168	185	228	251	<p><b>NOTE:</b> These values apply to fasteners as received from the supplier dry.</p>									
5/8 - 18		152	168	206	228	203	224	275	304										
3/4 - 10		238	262	322	355	318	350	431	474										
3/4 - 16		274	305	371	409	365	402	495	544										
7/8 - 9		350	386	474	523	466	515	631	698										
7/8 - 14		407	448	551	607	543	597	736	809										
1 - 8		537	592	728	802	716	790	970	1070										
1 - 14		670	740	908	1003	894	987	1211	1337										

Figure 2



## PARTS LIST - BALE HUGGER 3.50" CYLINDER, 49041

ITEM	PART NO.	DESCRIPTION	QTY.
1	49259	BASE, Cylinder	1
2	49262	TIE ROD	4
3	G9414074	NUT, Hex Thick 1/2-13	4
4	*	WASHER, Backup	2
5	*	O-Ring	2
6	49258	TUBE, Cylinder	1
7	6077-12	NUT, Lock 7/8-14	1
8	49261	PISTON	1
9	*	WASHER, Backup	2
10	*	O-RING	1
11	49260	HEAD, Cylinder	1
12	*	U-CUP	1
13	*	SEAL, Wiper	1
14	*	O-RING	1
15	49257	ROD, Cylinder	1
16	49264	CLEVIS ASSEMBLY, with nut and cap screw	1
17	G427589	SCREW, Cap 3/8-16 x 2-1/2, Grade 8	1
18	G120377	NUT, Hex, 3/8-16	1
19	49265	REPAIR KIT, (* Parts in Kit)	1

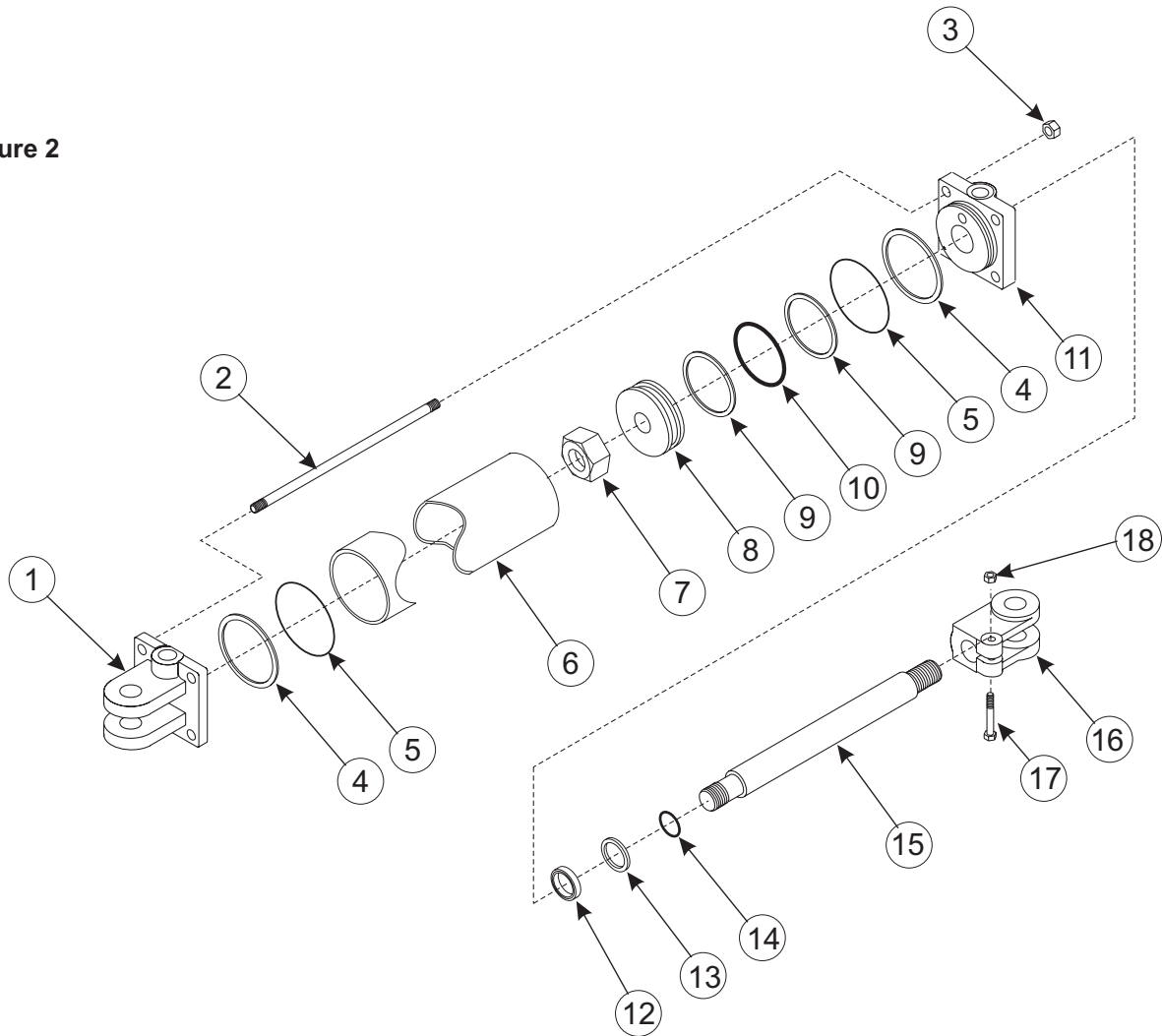
Figure 3

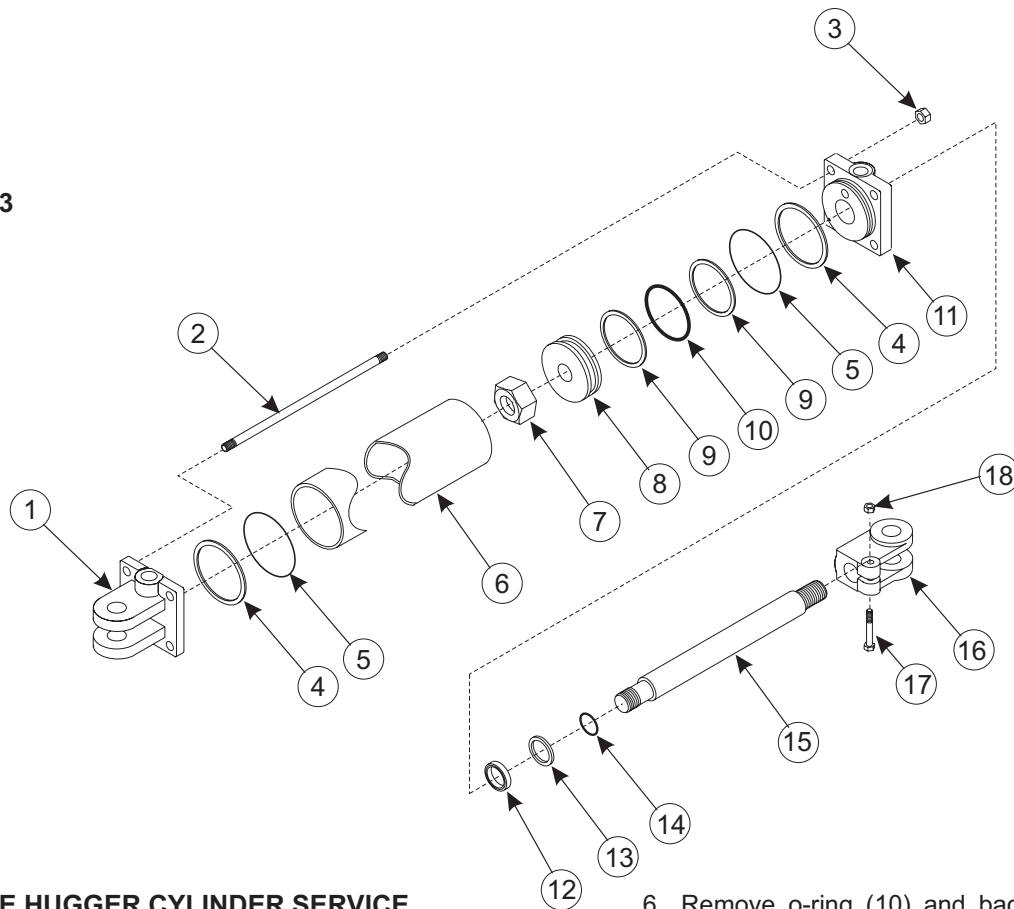

### BALE HUGGER CYLINDER SERVICE

The down pressure cylinder is designed to be reliable and easy to service. If it should malfunction in the warranty period, return the complete cylinder assembly, without disassembling, to an authorized service department or contact the authorized service department for instructions. Unauthorized disassembly of the cylinder in the warranty period will VOID WARRANTY.

The following is an outline of the procedure for disassembling and reassembling the cylinder.

**NOTE:** It is advisable to mark or tag all parts so they will be reassembled in their proper location.

#### • CYLINDER DISASSEMBLY

1. Remove the cylinder from bale hugger by removing cotter pin (16) and clevis pin (15) on rod and base ends (items 15 and 16 from figure 2, page 4).
2. Remove rod end clevis (16) from cylinder rod (15) by removing 3/8 x 2-1/2 cap screw (17) and lock nut (18).
3. Open cylinder by removing 1/2 nuts (3) from cylinder tie rods (2). Pull cylinder base (1), backup washer (4) and o-ring (5) off of base end of cylinder. Remove backup washer (4) and o-ring (5) from cylinder base (1).
4. Pull shaft (15) with all assembled parts out of cylinder tube (6). Remove lock nut (7) from end of shaft (15) and slide cylinder piston (8) and cylinder head (11) off the shaft.
5. Remove wiper seal (13) and u-cup (12) from inside of cylinder head. Remove backup washer (4) and o-ring (5).

6. Remove o-ring (10) and back-up washers (9) from outside of piston (8), and remove o-ring (14) from inside of piston.
7. Clean all parts including cylinder tube in a suitable solvent, then use air pressure to blow any dirt or excess solvent from all parts.
8. Examine all parts for wear or damage and replace if necessary.

#### • CYLINDER REASSEMBLY

**NOTE:** Be careful not to damage seals or o-rings on any sharp edges. Inspect all parts and remove any burrs or sharp edges if necessary before reassembling.

1. Place new u-cup (12), and wiper seal (13) into face of cylinder head (11). Install backup washer (4) and o-ring (5) onto cylinder head.
2. Place o-ring (10) and back-up washers (9) into groove on outside of cylinder piston (8). Place o-ring (14) into inside of cylinder piston.
3. Remove any sharp edges on threaded end of shaft (15). Lubricate wiper seal (13), and u-cup (12) in head and carefully slide head (11) onto shaft (15).
4. Lubricate o-ring (14) and carefully slide piston (17) onto shaft. Install lock nut (7).
5. Lubricate piston seals (9 & 10), o-ring (5) and backup washer (4) on head (11) and carefully slide piston (8) and head (11) into cylinder tube (6).
6. Lubricate o-ring (5) and backup washer (4) on cylinder base (1) and carefully slide cylinder base into other end of cylinder tube (6).
7. Fasten assembled cylinder together using tie rods (2) and nuts (3).

**NOTE:** Bale hugger safety decals are at locations listed below each decal part number. Replace decals if they are damaged or illegible. Replacement decals are available from your dealer

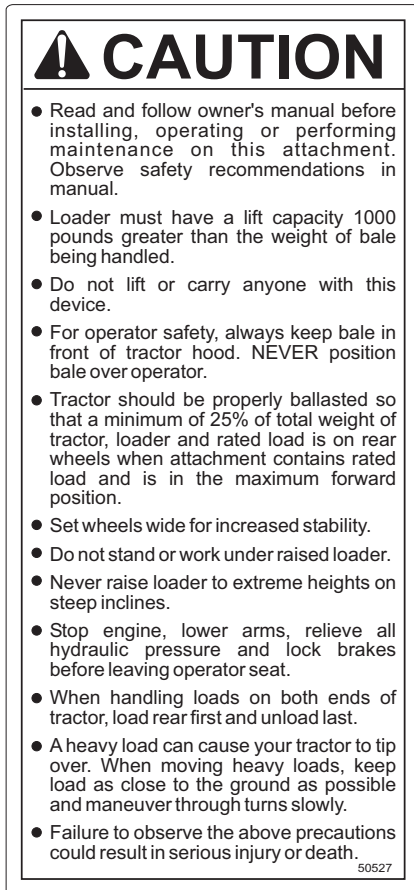

**DECAL P.N. 50527**

Location: Uprights of Front Frame



**DECAL P.N. 50528**

Location: Top Tubes of Front Frame



**DECAL P.N. 50529**

Location: Backside of Rear Frame



**DECAL P.N. 50530**

Location: Backside of Rear Frame