

OPERATION AND ASSEMBLY MANUAL

Keep With Operator's Manual

GRAPPLE FORK

CONTENTS

INTRODUCTION1

OPERATION2-4

ASSEMBLY5

PARTS LIST6-7

PLUMBING GRAPPLE FORK TO QUICK COUPLERS8

TORQUE SPECIFICATIONS9

GRAPPLE FORK CYLINDER SERVICE.....10-11

INTRODUCTION

Grapple fork kit can be installed using tools ordinarily available. Shut off tractor engine and engage tractor brakes during installation.

Grapple fork will not fit on manure fork or standard material buckets.

Tractor must be equipped with a valve which will be available for the grapple fork hydraulics. Loader needs to be equipped with hose kit to operate grapple using rear remotes 716847006 (2-6752), third function hose kit to mid mounted valve 716848006 (2-6750), or to *Faster* quick disconnect 716662036 (2-6755).

THE FOLLOWING INTENDED USE STATEMENTS ARE SUGGESTED TO HELP PREVENT ACCIDENTS

1. Using a front end loader without special attachments for handling large heavy objects, such as large round or rectangular bales, logs, fertilizer bags and liquid containers is **NOT RECOMMENDED**.
2. Handling large heavy objects can be extremely dangerous due to:
 - Danger of tractor tipping over.
 - Danger of upending tractor.
 - Danger of object falling or sliding down loader arms onto operator.

3. If you must perform above work, protect yourself by:
 - Using proper attachment.
 - Never lift loader higher than necessary to clear ground when moving.
 - Ballast tractor rear to compensate for load.
 - Move slowly and carefully avoiding rough terrain.
4. By properly balancing tractor and exercising caution, the loader with grapple fork attachment can be used to handle large round or rectangular bales and loose bulky material like hay and silage. Do not attempt to use loader to handle logs, bagged material or liquid containers, since such use is **NOT RECOMMENDED**.
5. Do not use grapple fork and loader bucket cylinders to apply downward force great enough to lift tractor tires off ground. This operation could damage grapple fork or make tractor unstable.

OPERATING GRAPPLE FORK

Operation of your tractor and loader with grapple fork option requires some same basic considerations as operation with a bucket, plus new requirements: you now have to operate a grapple fork while already operating your tractor and loader; and you must also take into account additional space requirements (added length and height) needed because of attached grapple fork.

GRASPING ROUND BALES

Approach bale with grapple fork open and bucket level. Use loader float position if bale is on ground.

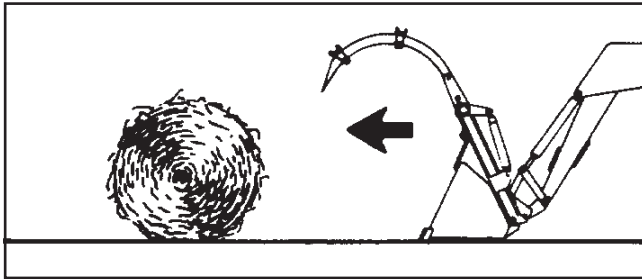

Ease valve control lever for grapple fork forward to close grapple fork around bale.

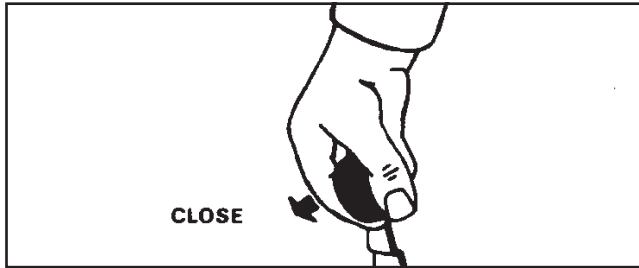

NOTE: While large round bales are best grasped as shown above, they may also be grasped from either side if necessary. **DO NOT ATTEMPT TO LIFT MORE THAN ONE LARGE ROUND BALE AT A TIME** as this can cause overloading of loader or tractor or cause unstable conditions.

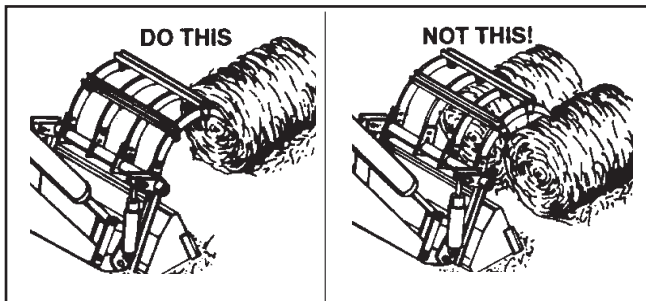

LIFTING AND CARRYING LOAD

Ease both loader control levers back to lift and roll bucket back.

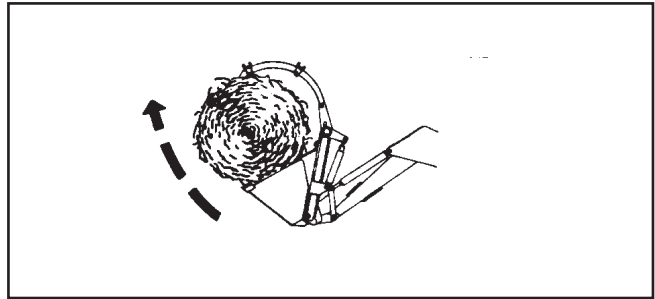

Position bucket low for maximum stability and visibility whether bucket is loaded or empty.

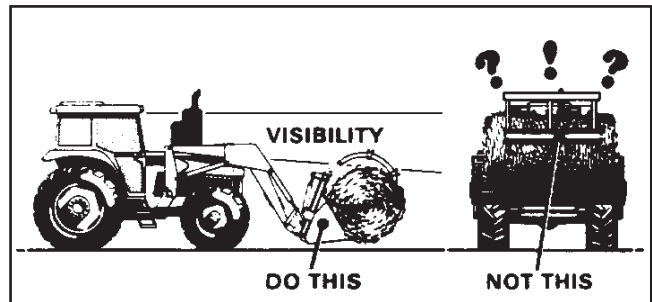

Use extreme care when operating loader on a slope. Carry load as low as possible. This keeps center of gravity for bale, tractor and loader low and will provide maximum tractor stability.



CAUTION: Operating a loader on a hillside is dangerous. Extreme care is recommended to avoid overturns.

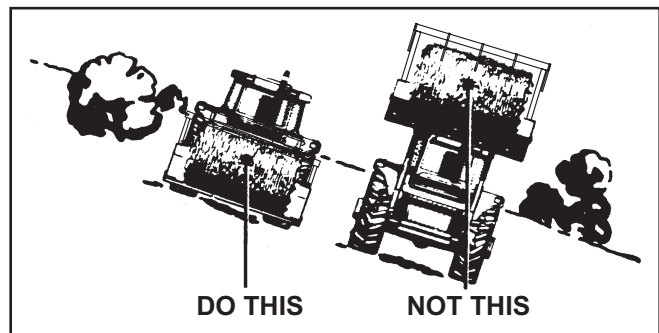

Even on level ground, transport bucket and load as low as possible to avoid tipping in case a wheel drops in a rut and to avoid power lines.

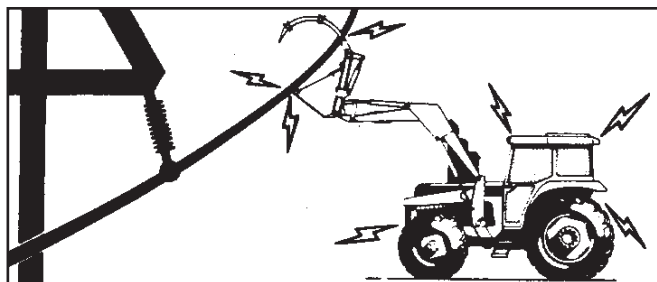

WARNING: Keep bucket, grapple fork and loader boom clear of overhead lines. Allowing loader boom or any attachments to contact overhead power lines may electrify entire tractor and electrocute (kill) operator.

• **LOADING INTO TUB GRINDER**

Lift bucket high enough to clear tub grinder sides. Move tractor toward tub grinder to position load near center. Extend bucket cylinders to position bucket in dump attitude.

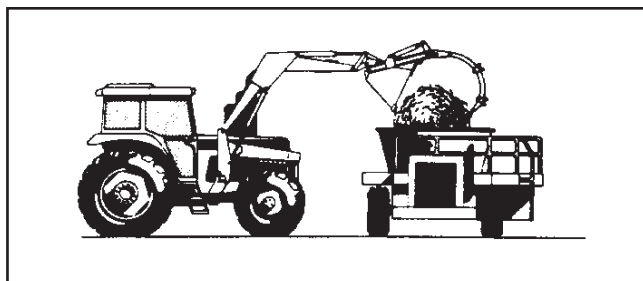

Gradually open grapple fork tines, allowing material to drop into tub grinder. For round bales it may be necessary to gradually set bale into tub grinder to avoid shock loading tub grinder due to bale weight and to avoid sudden load on grinder mechanism.

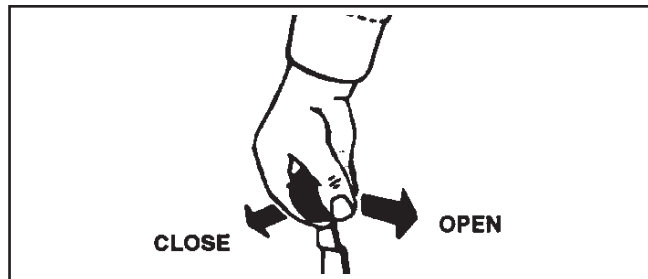

Roll bucket back, close grapple fork and back tractor away from tub grinder, then lower loader boom after dumping.

• **STACKING BALES**



WARNING: Because of size and weight of large bales, extreme care must be taken in handling them. Be aware of forces acting on stacked bales due to gravity and keep workers far from zones of potential hazard from shifting or falling bales. **DO NOT ALLOW BYSTANDERS!**

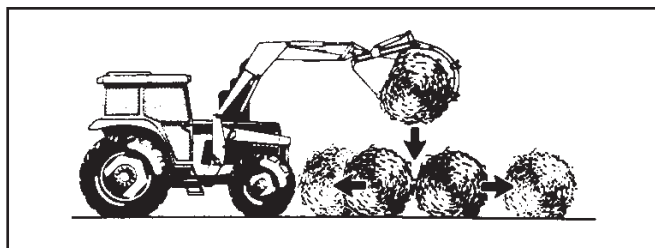

Use loader and grapple fork to gently position bale on stack, then release bale while removing bucket and fork.

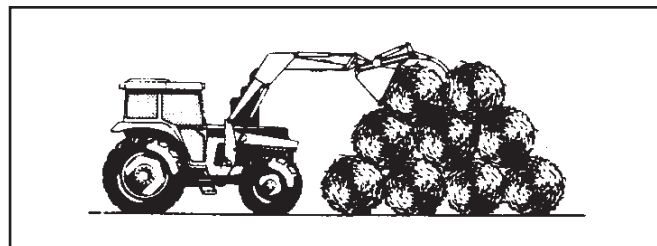

Slowly back tractor away from stack.

• **LOADING FROM A STACK, BUNKER SILO OR PIT SILO**

Choose a forward gear that provides sufficient ground speed for loading.

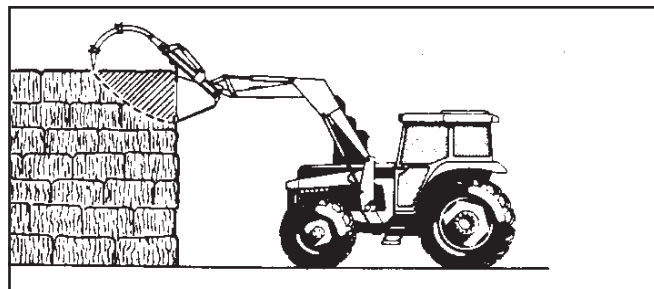

Touch pile as near as possible to top with bucket positioned in dump attitude and grapple fork open. Close grapple fork while maneuvering bucket to grasp loose material.



CAUTION: Loader lift and break-away capacity diminish as loader height is increased. Care must be taken not to grasp more material than your loader can safely support.

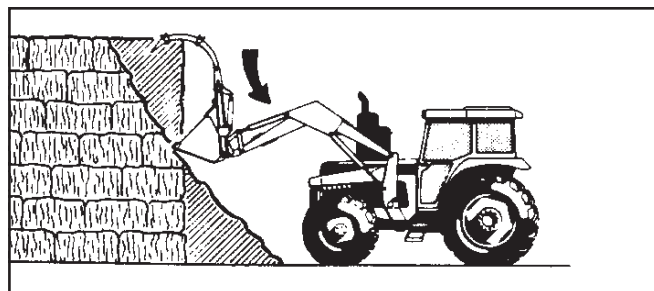

An alternative method is to use your loader and grapple fork to knock material down from top of pile so it can be loaded from ground.

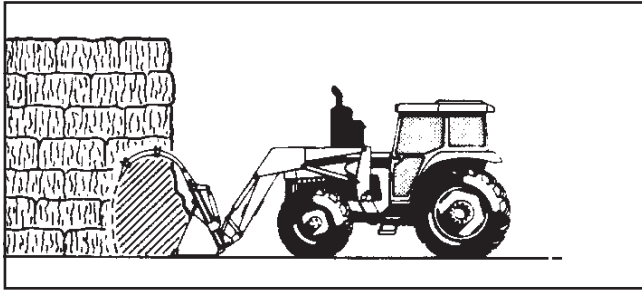

Exercise caution when undercutting a high pile. Avalanching material can be dangerous.

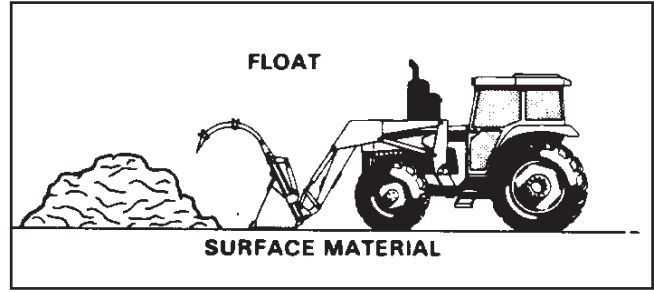

Keeping a level bucket and using loader float will reduce surface gouging and mixing surface material with stockpile material.

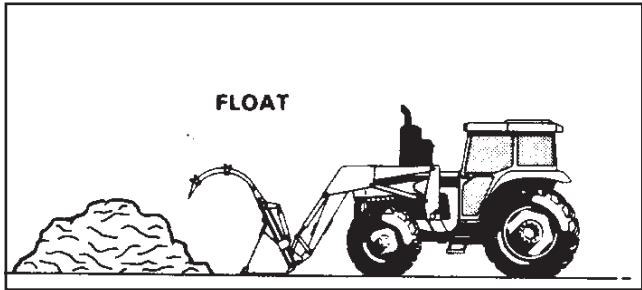

When loading material from ground, keep a level bucket and use lift control float position. If hydraulic down pressure is exerted on a bucket, it will wear faster than normal. Keep bucket level when approaching pile.

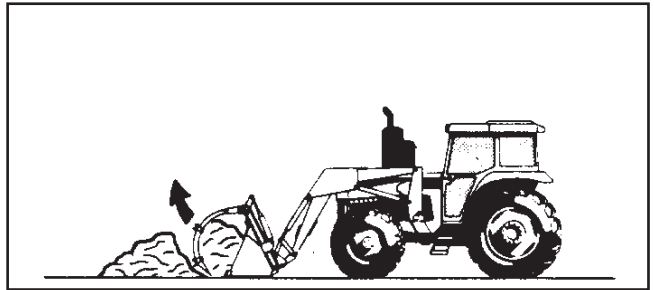

When a sufficient amount of material has accumulated in front of bucket, close grapple fork to grasp material and curl bucket.

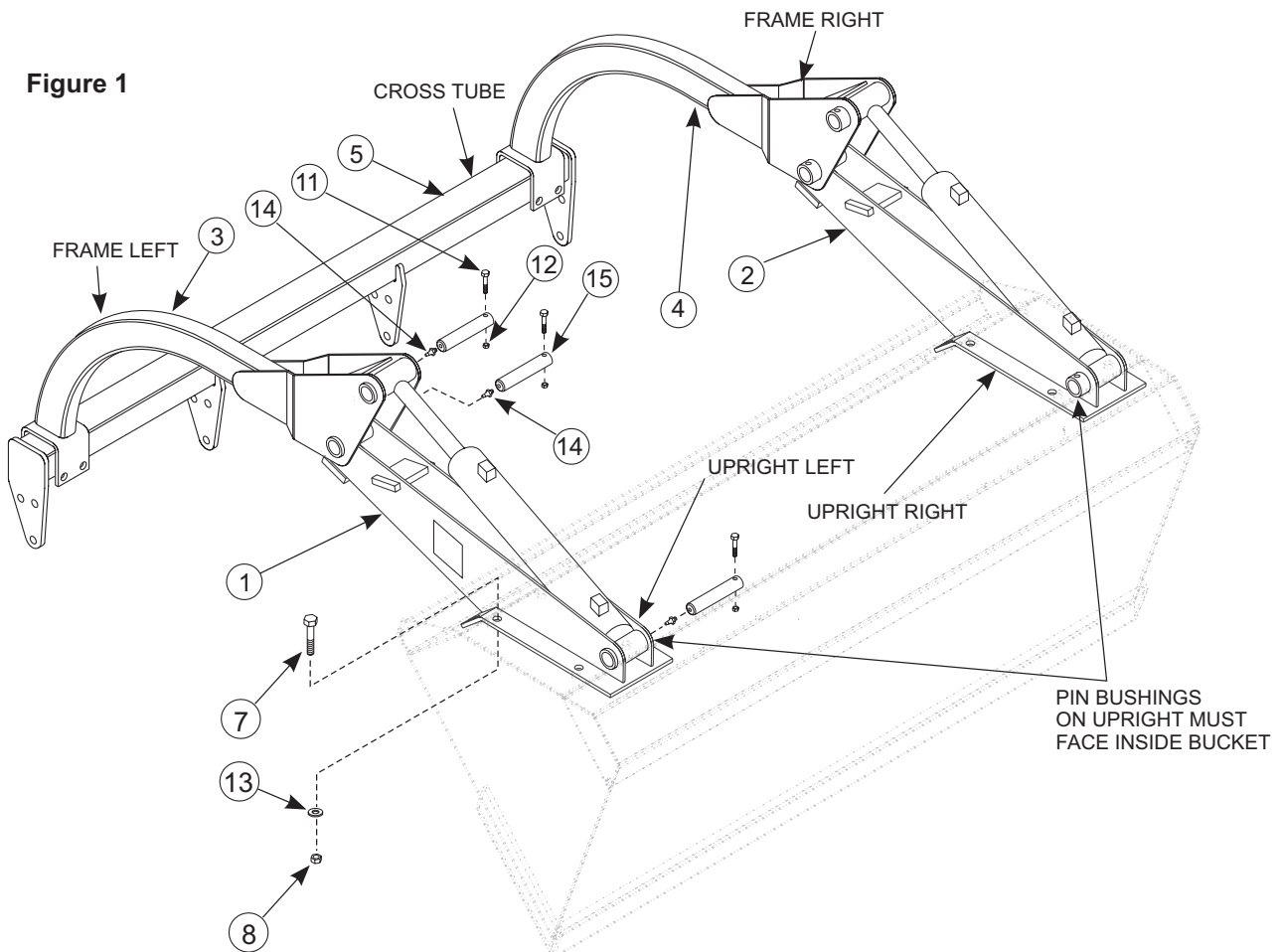

GRAPPLE FORK ASSEMBLY (Figures 1- 4)

NOTE: *It is not necessary to detach bucket from loader to install grapple fork.*

1. Remove top of pallet. Remove cap screw securing grapple tines to grapple uprights. Remove cap screws securing pins to grapple uprights, remove pins and cylinders.
2. With bucket attached to tractor rotate bucket until bucket back is parallel to ground. Place grapple uprights on bucket back. Holes-in bushings used to fasten pins should face toward center of bucket. Center uprights on bucket back center to center dimension of uprights should be 72" (See figures 4 & 5, Page 9).

NOTE: *Step 3 applies only to buckets not equipped with holes for mounting grapple. If the bucket already has mounting holes proceed to step 4.*

3. Using grapple uprights as a template mark and drill 12 - 13/16 (.81") diameter holes in the back of the bucket. Also drill 4 - 13/32 (.41) diameter holes. See figures 4 and 5 (page 9) for hole placement.

NOTE: *Hole location critical for proper grapple alignment.*

4. Install grapple uprights (1 & 2) to back of bucket using 12 - 3/4 x 2 cap screws (7) 16-3/4 flat washers (13) and 3/4 lock nuts (8) as shown in figure 1.
5. Attach grapple frame assemblies (3 & 4) to uprights (1 & 2) using 1-1/4 x 6.44 pins (15) and 3/8-16 x 2-1/4" cap screws (11) and 3/8-16 lock nuts (12). Again bushing securing pin should face towards center of bucket (See figure 1).
6. Attach grapple cylinders (17) to grapple uprights (1 & 2) and grapple frames (3 & 4) using 1-1/4 x 6.44 pins (15) and 3/8-16 x 2-1/4 cap screws (11) and 3/8-16 lock nuts (12). Ports on cylinders face rear or open side of grapple uprights. Remove plastic plugs from grapple cylinder ports.
7. Install grease fittings (14) into all pivot pins (15) as shown in figure 2.

8. Install 3/4 x 2 stop bolt (7) and jam nut (16) on grapple uprights (1 & 2).
9. Plumb grapple fork according to plumbing instructions and figure 3, page 8.

Start tractor and lift loader slightly. Rotate bucket until bucket bottom is level with ground. Install cross tube (5) to grapple frames using 3/4-10 x 5-1/2 cap screws (9) and 3/4 lock nuts (8). Cross tube installed with flat side of teeth brackets facing inside of bucket as shown in figure 2A. Adjust to center crosstube.

10. Tighten and torque all hardware. Cap screws securing cross tube (5) to grapple fork frames (3 & 4) are not torqued to maximum torque specification of 262 ft. lbs., but are tightened until clevis starts to deform.

NOTE: *Torque all other hardware to specifications from chart on page 9.*

11. Attach overhead to cross tube and remove slack. Attach teeth to cross tube as shown in illustration. Teeth are on inside surface of tooth brackets.
12. Remove overhead hoist. Adjust grapple stop bolt to prevent teeth from projecting below bucket cutting edge. (See figure 2B for various positions).
13. Attach hoses to third function kit. Start tractor and cycle grapple to purge air from system. Check hydraulic fluid level and replenish if necessary.

NOTE: *Torque all other hardware to specifications from chart on page 9.*

PARTS LIST - GRAPPLE FORK ASSEMBLY (Figures 1, 2 & 3)

Item	SMC Part No.	NH Part No.	Description	Qty.
1	48862-1	86583610	UPRIGHT ASSEMBLY, Left	1
2	48862-2	86583611	UPRIGHT ASSEMBLY, Right	1
3	48380-1	86583612	UPPER TUBE ASSEMBLY, Left	1
4	48380-2	86583613	UPPER TUBE ASSEMBLY, Right	1
5	48386	86583614	CROSS TUBE ASSEMBLY	1
6	47872	86583615	TINE	4
7	G271771	87403	SCREW,Cap, 3/4-10 x 2	22
8	G9414076	962598	NUT, Lock, 3/4-10	24
9	G9429887	86507002	SCREW,Cap, 3/4-10 x 5-1/2	4
10	G180126	88616	SCREW, Cap, 3/8-16 x 1-1/2	4
11	G180132	88011	SCREW, Cap, 3/8-16 x 2-1/4	6
12	G9413534	9637692	NUT, Lock, 3/8-16	10
13	G131000	249100	WASHER, Flat, 3/4	16
14	6075-2	PL	FITTING, Grease	6
15	46584	86583636	PIN, 1-1/4 x 6.44	6
16	G426897	84972	NUT, Jam, 3/4-10	2
17	47520	86583616	CYLINDER ASSEMBLY	2
18	43000-3	86583617	HOSE, 3/8 x 32 (See figure 3 - page 8)	1
19	43000-4	86583618	HOSE, 3/8 x 36 (See figure 3 - page 8)	1
20	43000-5	86583619	HOSE, 3/8 x 50 (See figure 3 - page 8)	1
21	43000-6	86583620	HOSE, 3/8 x 54 (See figure 3 - page 8)	1
22	48554-1	86583621	HOSE, 3/8 x 64 (See figure 3 - page 8)	2
23	6137-4	86583622	COUPLER, Male (See figure 3 - page 8)	2
24	31213-5	330346	FITTING,Elbow, 45°, 9/16-18 X 9/16-18 (See figure 3 - page 8)	4
25	36665-1	76355	FITTING, Union Tee (See figure 3 - page 8)	2
26	13722	86583623	HOSE CLAMP (See figure 3 - page 8)	4
27	34853-37	86583624	SLEEVE (See figure 3 - page 8)	1
28	38683	86583625	DECAL, Warning	1
29	4838-5	86583637	DUST CAP	2
30	8137-1	86582400	STRAP, Adjustable, .19 x11	2
31	48857	86583638	DECAL, Warning	2

Figure 2
Grapple Fork Assembly

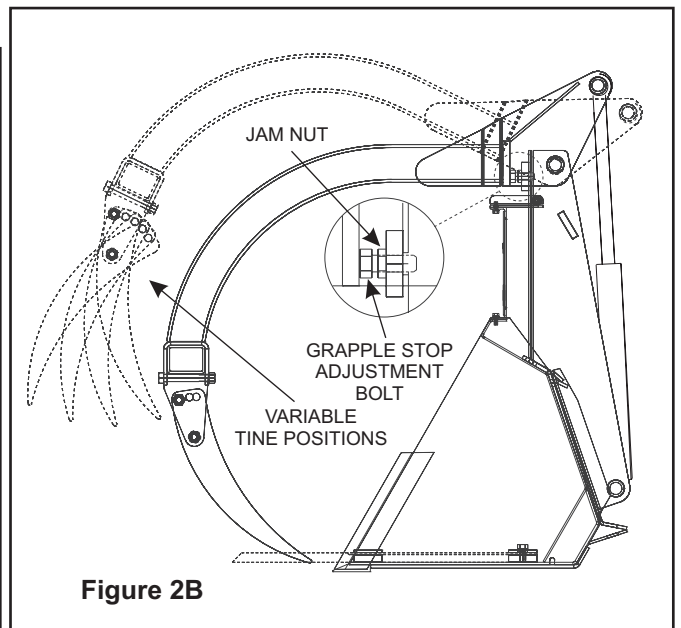
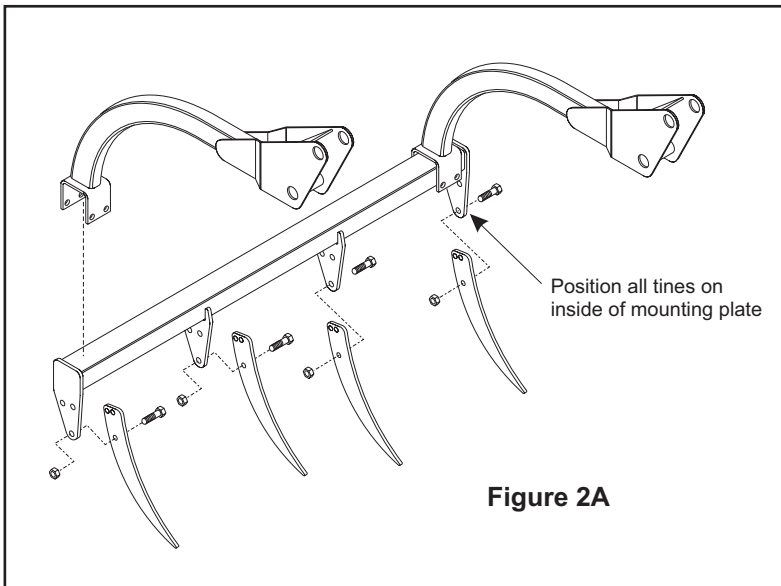
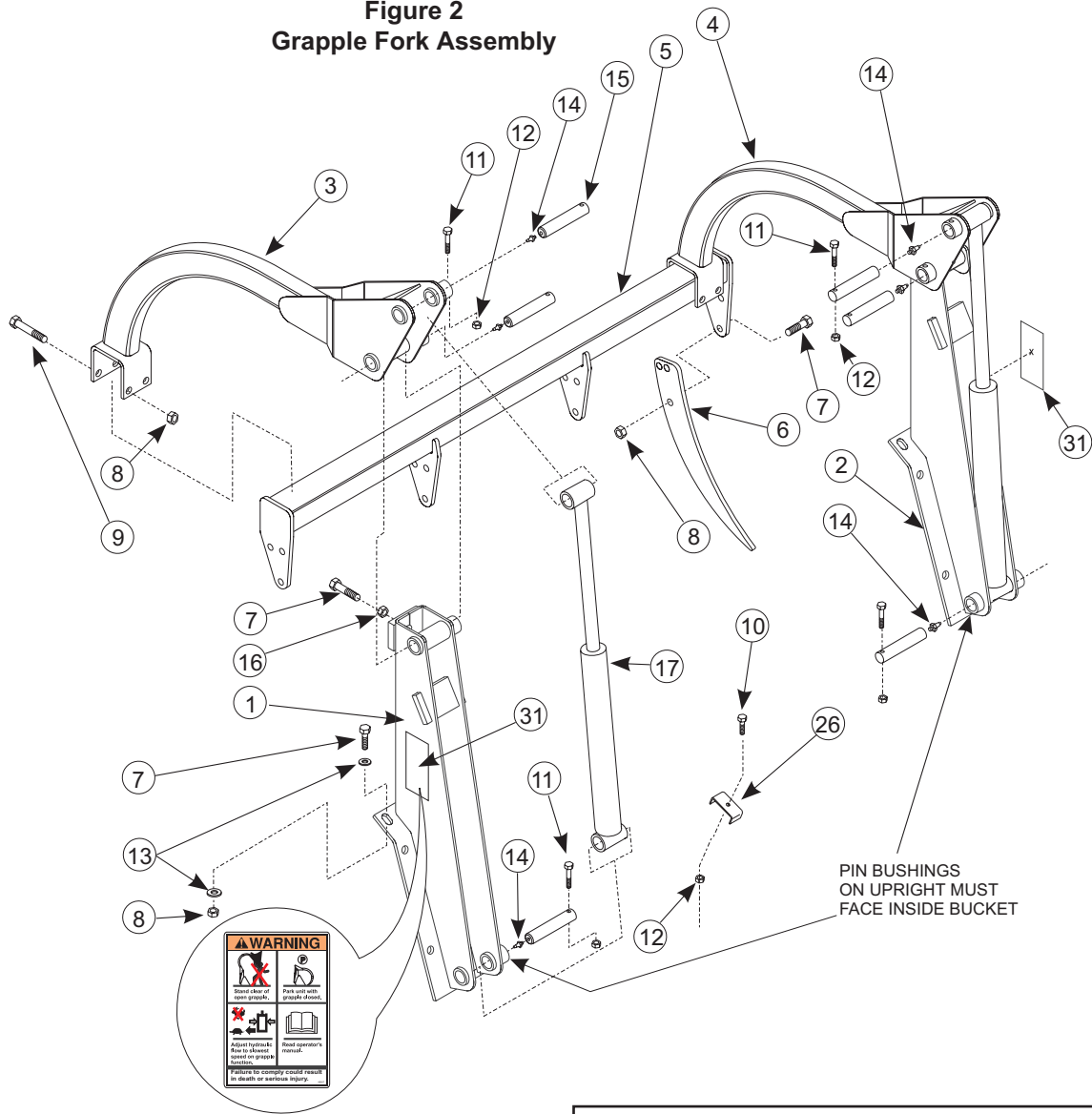
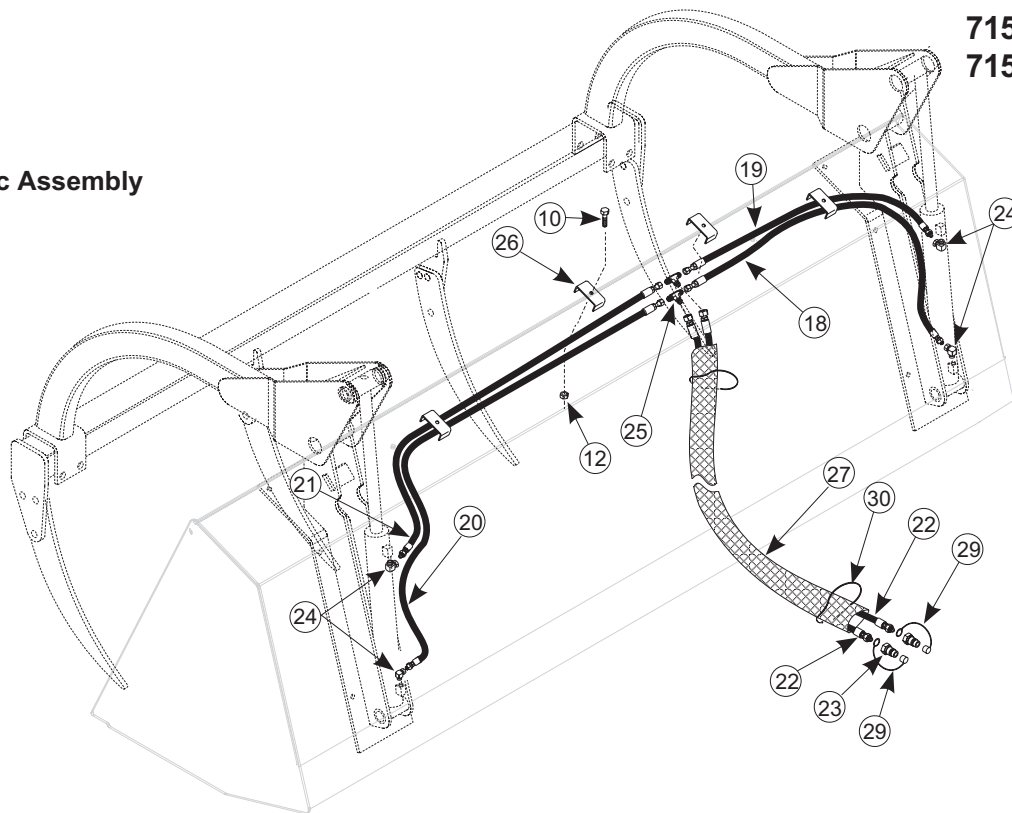

Figure 3
Hydraulic Assembly



PLUMBING GRAPPLE FORK TO TRACTOR
(Figure 3 & 3A)

1. Attach 45° fitting (24) to each port of cylinder assemblies (17).
2. Connect union tee fitting (25) between 3/8 x 32" (18) hose and 3/8 x 50" hose (20).
3. Attach 3/8 x 32" hose (18) to 45° fitting (24) on base end of right cylinder assembly (17) and 3/8 x 50" hose (20) to 45° fitting (24) on base end of left cylinder assembly (17).
4. Connect union tee fitting (25) between 3/8 x 36" hose (19) and 3/8 x 54" hose (21).
5. Attach 3/8 x 36" hose (19) to 45° fitting (24) on rod end of right cylinder assembly (17) and 3/8 x 54" hose (21) to 45° fitting (24) rod end of left cylinder assembly (17).
6. Attach hoses to bucket back using four hose clamps (26), 3/8-16 x 1-1/2 cap screws (10) and 3/8-16 lock nuts (12). Do not overtighten, crushing hose.
7. Slide hose sleeve (27) over 3/8 x 64" hoses (22) and attach hoses to union tees (25). Punch holes through nylon sleeve (27) near each end of sleeve, using adjustable plastic straps (30), secure nylon sleeve (27) to hoses (22) by running adjustable straps (30) through holes and around sleeve to avoid slippage and interference with moving parts.
8. Apply thread sealant to male pipe ends of hose (22). Attach dust caps (29) and male couplers (23) to hoses (22). Make sure all hydraulic fittings have been tightened.
9. Operate loader to extend and retract cylinders to purge all air from system. Adjust flow control for third function to reduce flow to insure safe operation of grapple fork.



WARNING: *To avoid serious injury:*

- Do not allow anyone within 10 feet of loader and grapple fork during operation or anytime grapple fork is in open position.
- ALWAYS keep grapple fork closed except when loading or unloading bucket.
- Before operating grapple fork, adjust hydraulic flow speed control on valve body to slower speed setting. Refer to tractor operators manual for instructions.

Figure 4
96" Bucket

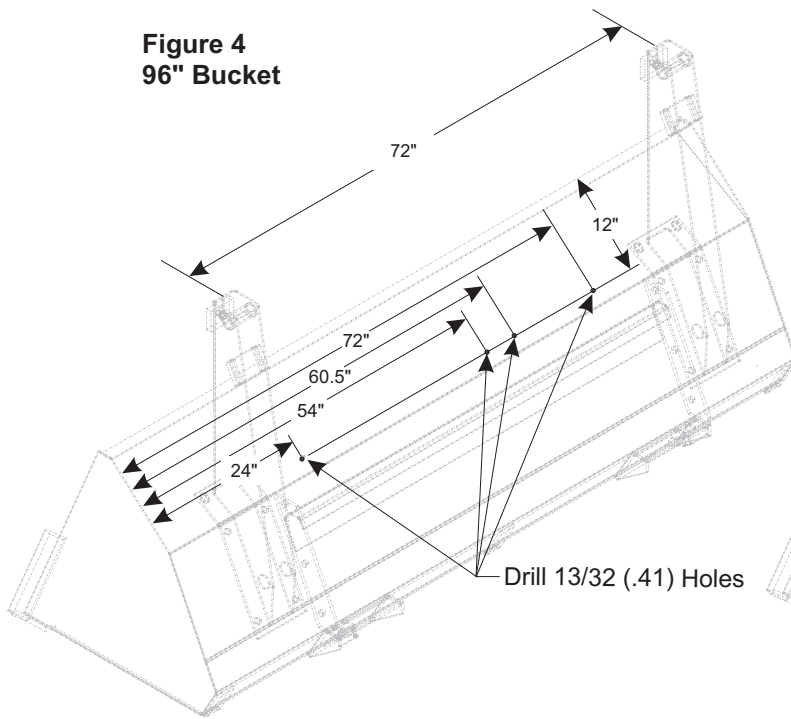
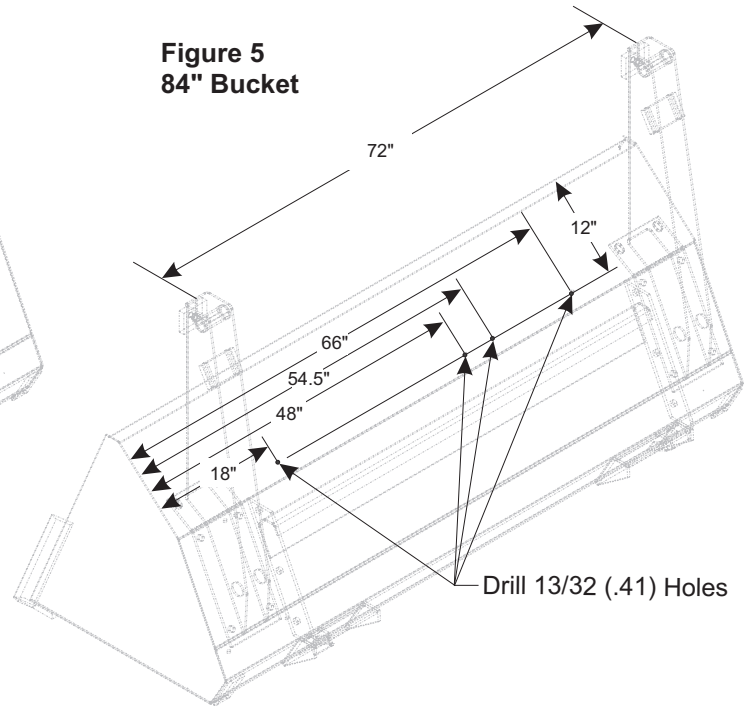

Figure 5
84" Bucket



GENERAL TORQUE SPECIFICATIONS

USE THE FOLLOWING TORQUES WHEN SPECIAL TORQUES ARE NOT GIVEN

AMERICAN STANDARD CAP SCREWS					METRIC CAP SCREWS												
SAE Grade	5				8				Metric Class	8.8				10.9			
Cap Screw	TORQUE				TORQUE				Cap Screw	TORQUE				TORQUE			
Size	FT-LBS		Nm		FT-LBS		Nm		Size	FT-LBS		Nm		FT-LBS		Nm	
Inches	MIN	MAX	MIN	MAX	MIN	MAX	MIN	MAX	Millimeters	MIN	MAX	MIN	MAX	MIN	MAX	MIN	MAX
1/4-20	6.25	7.25	8.5	10	8.25	9.5	11	13	M6x100	6	8	8	11	9	11	12	15
1/4-28	8	9	11	12	10.5	12	14	16	M8 x 1.25	16	20	215	27	23	27	31	36.5
5/16 - 18	14	15	19	20	18.5	20	25	27	M10 x 1.50	29	35	39	47	42	52	57	70
5/16 - 24	17.5	19	23	26	23	25	31	34	M12 x 1.75	52	62	70	84	75	91	102	123
3/8 - 16	26	28	35	38	35	37	47.5	50	M14 x 2.00	85	103	115	139	120	146	163	198
3/8 - 24	31	34	42	46	41	45	55.5	61	M16 x 2.50	130	158	176	214	176	216	238	293
7/16 - 14	41	45	555	61	55	60	74.5	81	M18 x 2.50	172	210	233	284	240	294	325	398
7/16 - 20	51	55	69	745	68	75	92	102	M20 x 2.50	247	301	335	408	343	426	465	577
1/2 - 13	65	72	88	975	86	96	116	130	M22 x 2.50	332	404	450	547	472	576	639	780
1/2 - 20	76	84	103	114	102	112	138	152	MM24 x 3.00	423	517	573	700	599	732	812	992
9/16 - 12	95	105	129	142	127	140	172	190	M27 x 3.00	637	779	863	1055	898	1098	1217	1488
9/16 - 18	111	123	150	167	148	164	200	222	M30 x 3.00	872	1066	1181	1444	1224	1496	1658	2027
5/8 - 11	126	139	171	188	168	185	228	251	NOTE: These values apply to fasteners as received from the supplier dry.								
5/8 - 18	152	168	206	228	203	224	275	304									
3/4 - 10	238	262	322	355	318	350	431	474									
3/4 - 16	274	305	371	409	365	402	495	544									
7/8 - 9	350	386	474	523	466	515	631	698									
7/8 - 14	407	448	551	607	543	597	736	809									
1 - 8	537	592	728	802	716	790	970	1070									
1 - 14	670	740	908	1003	894	987	1211	1337									

GRAPPLE FORK CYLINDER DISASSEMBLY (Figures 6 & 7)

NOTE: Use penetrating fluid in cylinder groove to loosen retaining ring (14) before disassembling cylinder.

1. Hold cylinder tube (13) stationary and rotate cylinder head (4) so beveled end of wire ring (14) will thread out through slot. Using Vicegrip on wire to pull as head is rotated will ease removal.

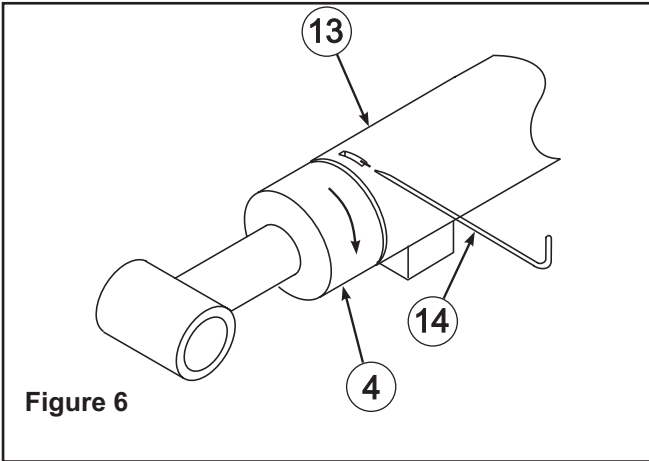

2. Pull shaft (1) with all assembled parts out of cylinder tube (13).

NOTE: Resistance will be felt until head seal (7) and piston seal (8) slides over the wire retaining ring groove. This procedure may shave some off these seals.

3. Remove lock nut (12) from end of shaft and slide cylinder piston (10), and cylinder head (4) off the shaft.
4. Remove piston wear ring (11), piston seal (8) and o-ring (9) from out side grooves of piston (10).
5. Remove wiper seal (2), rod seal (3), wear ring (5) from inside of cylinder head and o-ring (7) and back-up ring (6) from groove on outside of head.
6. Clean all parts, including cylinder tube, in a suitable cleaning solvent, then use air pressure to blow any dirt or excess solvent from all parts.
7. Examine all parts for wear or damage and replace, if necessary.

GRAPPLE FORK CYLINDER ASSEMBLY

NOTE: Be careful not to damage seals, packings and o-rings on the edges or holes in cylinder tube. Inspect and remove burrs and sharp edges if necessary before reassembling.

1. Place rod seal (3) into groove inside cylinder head.

NOTE: Lips of seal must face toward the inside of head.

2. Install wiper seal (2) with lip of seal facing out and flush with top of cylinder head. Install wear ring (5) inside other end of head.
3. Place o-ring (7) with back-up ring (6) in groove on outside of head. Back-up ring must be on rod side.
4. Remove sharp edges on outer edge of threaded end of shaft (1). Lubricate wiper seal (2), rod seal (3) and wear ring (5) in head and carefully slide head onto shaft.
5. Place o-ring (9), piston seal (8) and piston wear ring (11) in grooves on outside of piston.

NOTE: For easier installation, place piston seal (8) in 120° F water to warm seal.

6. Slide piston (10) onto threaded end of shaft. Install 3/4 lock nut (12) and tighten to 150 ft. lb. of torque.
7. Lubricate piston wear ring (11) and piston seal (8) on piston (10), o-ring (7) and back-up ring (6) on head (4) and inside of cylinder tube (13) then carefully slide piston and head into cylinder tube (13).
8. Insert wire retaining ring (14) into slot in cylinder tube (13) and turn cylinder head while applying pressure to wire ring to thread it into groove.

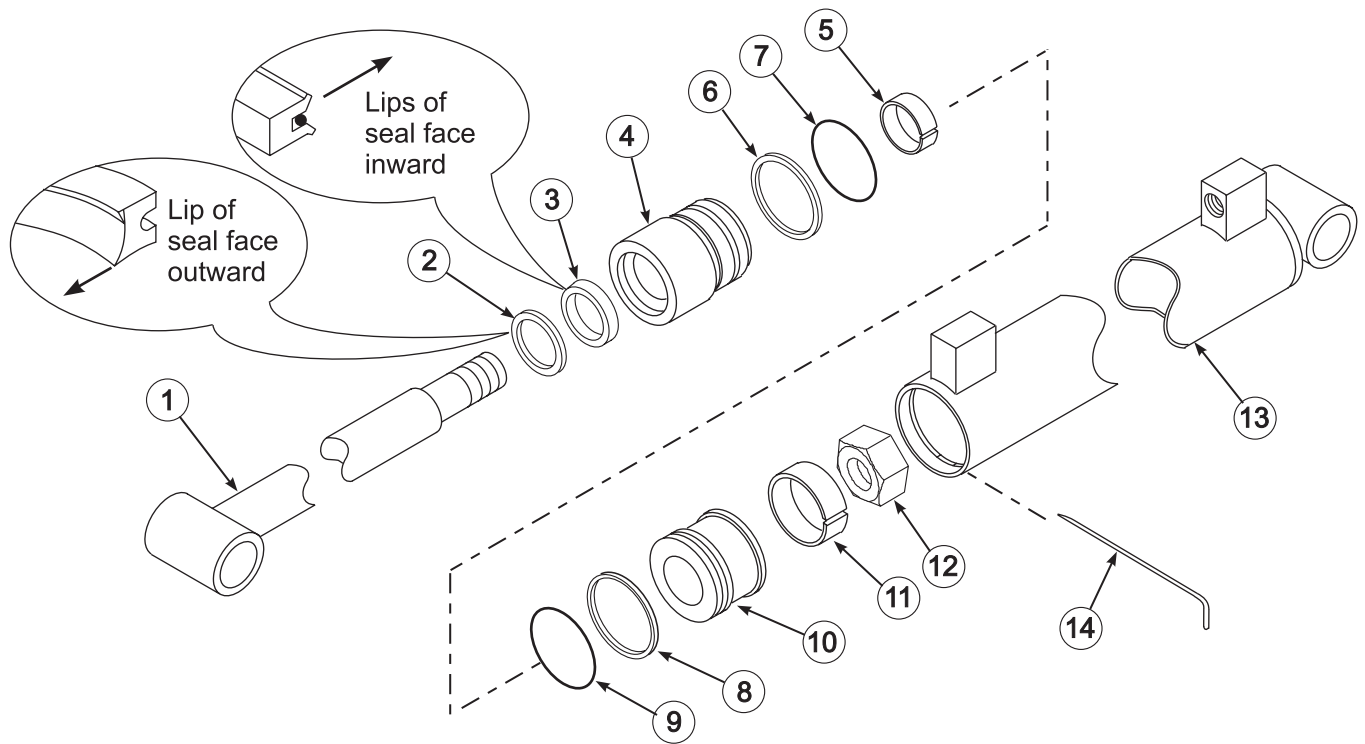

Figure 7

PARTS LIST - GRAPPLE FORK CYLINDER 2.00 (47520) (Code MQ)

Item	SMC Part No.	CNH Part No.	Description	Qty.
1	47522	SML47522	ROD, Weldment, 1.38	1
2	*	*	SEAL, Wiper	1
3	*	*	ROD, Seal	1
4	44021	SML44021	HEAD	1
5	*	*	RING, Wear	1
6	*	*	RING, Back-up	1
7	*	*	O-RING	1
8	*	*	SEAL, Piston	1
9	*	*	O-RING	1
10	36592	SML36592	PISTON	1
11	*	*	RING, Wear	1
12	38998-3.	SML389983	NUT, Lock	1
13	47518	SML47518	TUBE, Cylinder, Assembly	1
14	*	*	RETAINER, Wire	1
*	43755	SML43755	Repair Kit, Includes (*) Items	1

SAFETY DECALS

NOTE: Loader safety decals are at locations listed below each decal part number. Replace decals if they are damaged or illegible. Replacement decals are available from your dealer.

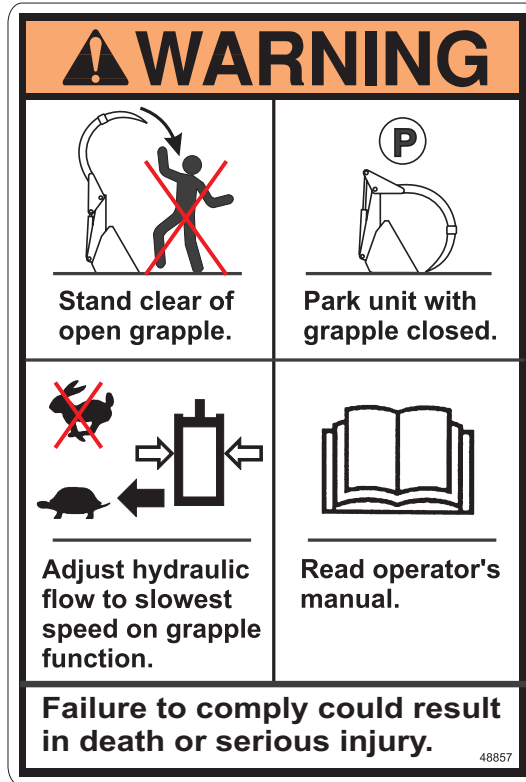

DECAL P.N. 48857

Location: Grapple Fork Left and Right
Frame Uprights

INSTALLATION INSTRUCTIONS