

MOUNTING KIT INSTRUCTIONS

NEW HOLLAND 7312 & 7314 LOADERS NEW HOLLAND TRACTORS

MODEL	2WD SN 126647B AND HIGHER	4WD SN 116200B AND HIGHER	LESS CAB	WITH CAB	2WD & FWD	FWD Terra Glide™
8160	X	X	X	X		
8260	X	X	X	X		
8360	X	X	X	X		
8560	X	X		X		
TM 115, 125, 135, 150 & 165				X	X	X

NOTE: 8160, 8260, 8360 & 8560 FWA tractors prior to SN 116200B and 2WD tractors prior to SN 126647B have old front bolster which requires Mount Kit 715831001 (2-6289).

Mount kit can be installed using tools ordinarily available. Shut off engine and engage brakes during installation.

NOTE: Leave all attaching hardware loose until loader is completely assembled to facilitate assembly and proper alignment. Torque hardware to torque specifications on page 8.

Front fenders, front weights and front weight bracket must be removed, if so equipped.

FWA tractors are equipped with front axle oscillation stops and must be used with loader installation. Tractor steering stops also must be adjusted to provide a minimum clearance of 3/4" between front tire and any part of loader on full left and right lock with front axle fully oscillated. Refer to tractor operator's manual for steering stop adjustment.

NOTE: If FWD Terra Glide™ tractors are equipped with engine side rails they must be removed. Do Not reuse hardware for loader mount installation. Paint touch-up may be required on side of tractor front castings after loader mountings have been installed.

INSTALLING MOUNTING BRACKETS (Figure 1)

1. Install front mounting bracket (1), with longer flange on top, to tractor using 20MM x 50MM cap screws (10) and 20MM lock washers (14).

2. Install right and left mid mounting brackets (3 & 4) to tractor front casting using 20MM x 55MM cap screws (19), 3/4 flat washers (15) and 20MM lock washers (14) and to tractor transmission casting using 20MM x 50MM cap screws (10), and 20MM lock washers (14).

3. Fasten crosstube assembly (2) to right and left mid mounting brackets (3 & 4) using 1/2 x 2 cap screws (8), 1/2 flat washers (7), and 1/2 lock washers (9) in front holes and 1/2 x 1-3/4 cap screws (5), 1/2 flat washers (7) and 1/2 lock nuts (6) in rear holes.

NOTE: On Terra-Glide tractors only, if more clearance is required between crosstube and underside of one piece drive shaft shield, remove shield and cut away material as illustrated. Paint touch-up may be required before reinstalling revised two piece drive shaft shield.

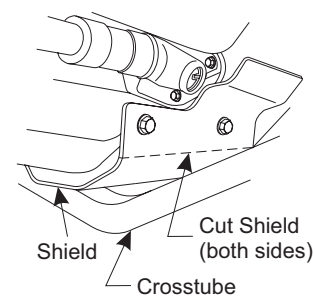

NOTE: Midmounting brackets (3 & 4) have 1/2 inch nuts welded inside upright for installing 1/2 x 2 cap screws (8).

NOTE: Mounting hardware should be retorqued after initial 10 hours of use and after every additional 100 hours of use (per torque specifications on page 8).

2-6775
2-7019

715832016
715832026

PARTS LIST - MOUNTING KIT

ITEM	SMC Part No.	CNH Part No.	DESCRIPTION	QTY.
1	43994	SML43994	BRACKET, Front Mounting	1
2	48495	SML48495	CROSSTUBE, Assembly	1
3	48490	SML48490	BRACKET, Mid Mounting, Right (Not shown)	1
4	48488	SML48488	BRACKET, Mid mounting, Left	1
5	G180179	9707516	SCREW, Cap, 1/2-13 x 1-3/4	4
6	G9414074	9636698	NUT, Lock, 1/2-13	4
7	G120396	87364	WASHER, Flat, 1/2	8
8	G180181	9706716	SCREW, Cap, 1/2-13 x 2	4
9	G120384	80679	WASHER, Lock, 1/2	4
10	6090-107	9847023	SCREW, Cap, 20MM-2.50 x 50MM	14
11	G271723	86505999	SCREW, Cap, 5/8-11 x 2	2
12	G121574	84057	WASHER, Lock, 5/8	4
13	G9414076	9626598	NUT, Lock, 3/4-10	4
14	G11500166	9847025	WASHER, Lock, 20MM	22
15	G131000	86511191	WASHER, Flat, 3/4 Std.	8
16	48512	SML48512	YOKE, Front, with Decals	1
17	G271773	9706701	SCREW, Cap, 3/4-10 x 2-1/2	2
18	39240	86582430	DECAL, Warning, Do Not Tow...	2
19	6090-119	86503256	SCREW, Cap, 20MM-2.50MM x 55MM	8
20	G131016	87365	WASHER, Flat, 5/8	4
21	G271777	88558	SCREW, Cap, 3/4-10 x 3-1/2	2
22	G271725	88556	SCREW, Cap, 5/8-11 x 2-1/2	2
23	48492	SML48492	SPACER (Use with TM FWD Terra Glide Tractors Only)	2
24	48549	SML48549	SPACER (Use with TM FWD Terra Glide Tractors Only)	2

Figure 1
Installing Mounting
Brackets

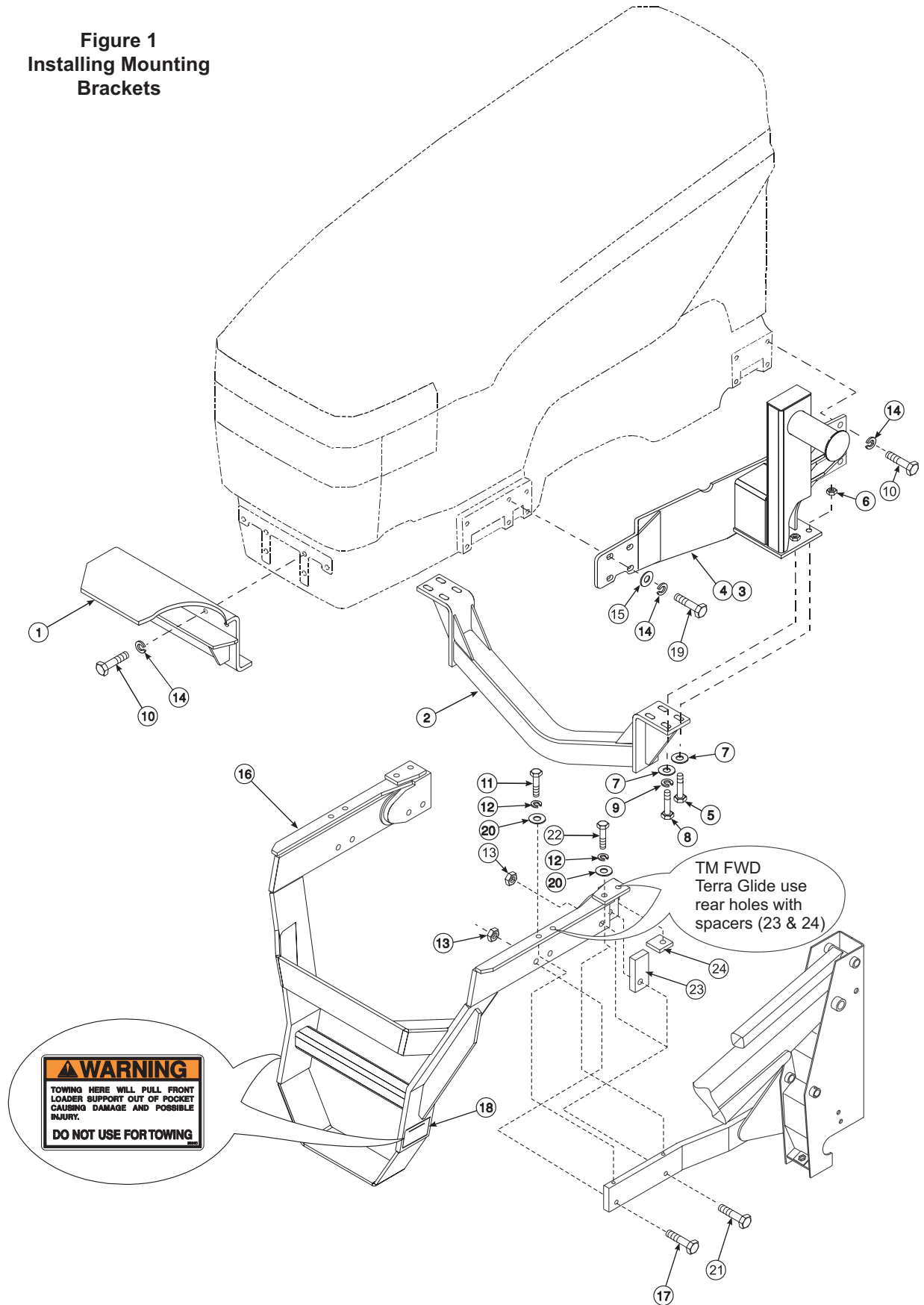

INSTALLING YOKE - 7314 LOADER

Position pallet on solid surface. If surface is not solid use wood blocks for support when installing loader.

1. Using overhead hoist with nylon sling, lift loader at balance point. Remove hardware which secures loader to pallet. Remove pallet from loader.

NOTE: Hinge hardware is used to secure braces to sideframes. Retain for later use.

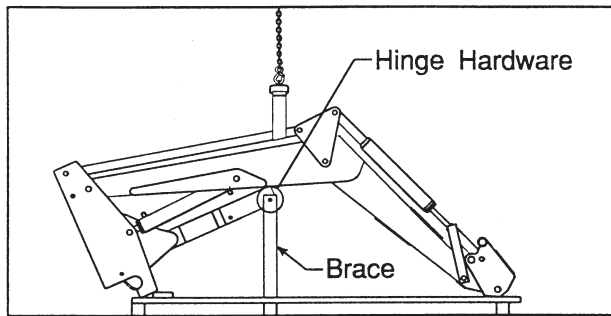

2. Lower loader to ground and move nylon sling to rear of loader boom. Raise rear of boom off the ground.

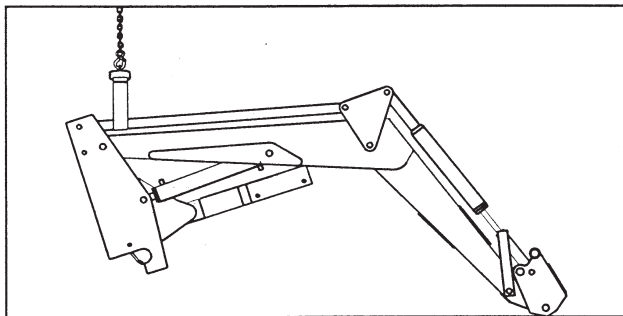

3. Position yoke (16) on loader side frames (insert yoke from front of loader). Install yoke to loader sideframes using 3/4 x 2-1/2 cap screws (17), 3/4 x 3-1/2 cap screws (21) and 3/4 lock nuts (13) in side holes and 5/8 x 2 cap screws (11), 5/8 x 2-1/2 cap screws (22), 5/8 flat washers (20) and 5/8 lock washers (12) in top holes. Use spacers (23 & 24) when installing with Terra Glide™ axle tractors. Lower loader to ground. Refer to figure 1 for proper yoke (16) position.

NOTE: It may be necessary to clamp sideframes together to align 5/8 inch holes in top of yoke with holes in side frames.

INSTALL HYDRAULIC KIT TO LOADER

Install hydraulics kit to loader. Refer to sheet packed with kit for proper instructions.

INSTALLING LOADER TO MOUNTING BRACKETS - 7314 LOADER

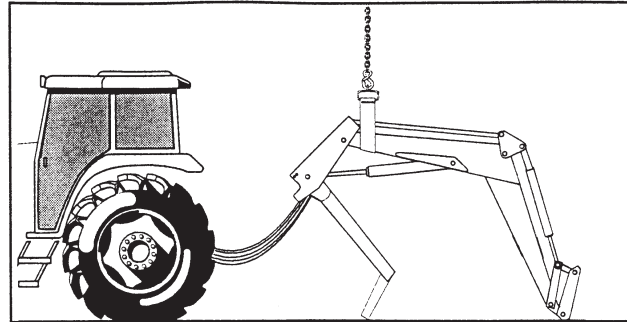

WARNING: To avoid injury during installation of quick attach loader, do not permit bystanders within ten feet of loader.

1. Back tractor directly behind loader facing in opposite direction.
2. Connect hoses from loader to tractor rear remotes.
3. Using overhead hoist to steady loader, activate lift cylinders until loader sideframes are high enough to clear front tires.



WARNING: Overhead hoist must be used to steady loader until rear of loader is raised. Without overhead hoist, loader will tip over backwards.

4. Shut off engine and engage brakes. Relieve pressure on hoses by moving control lever back and forth several times.

NOTE: Be sure control lever is not in "float" position.

5. Disconnect hoses from tractor rear remotes. Turn tractor around and drive it under loader until mid-mounting tubes are under loader sideframes. Shut off engine and engage brakes. Connect hoses to tractor hydraulics (refer to instruction sheet for proper connections).

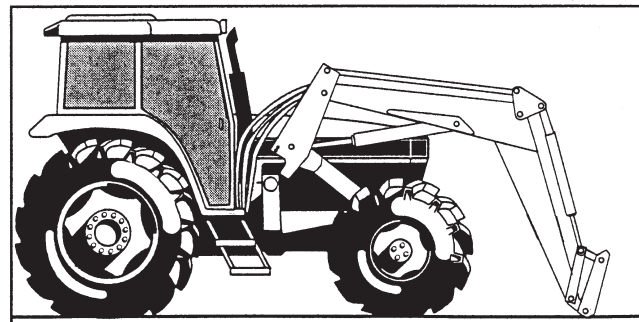

6. Remove overhead hoist.

INSTALLING LOADER TO MOUNTING BRACKETS - 7314 (Continued)

6. Place 3/4 x 3 cap screw and 3/4 flat washer in side frame to block hinge open. Store 3/4 flex lock nut on extra threads of 3/4 x 7-1/2 hinge bolt. Activate bucket cylinders to extend bucket cylinders completely.

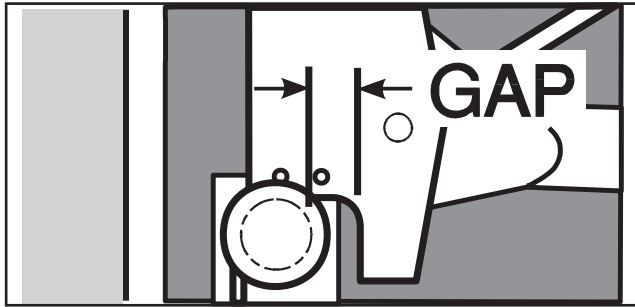

NOTE: Front of loader is now resting on quick attach torque tube.

7. Slowly drive forward while operating lift control lever to retract lift cylinders. Position loader so hinges hook over midmounting tubes.

NOTE: Position loader uprights so mid mounting tubes are tight against hinges until loader has finished rotating so loader front bumper tube does not hit lower flange of front mounting channel.

8. With tractor in neutral, retract lift cylinders, bringing side frame up so front yoke tube contacts upper flange of front mounting bracket channel. Move tractor ahead until front yoke tube engages in front mounting channel and upright hinges can clamp around mid mounting tube. Engage tractor brakes and shut off tractor engine.

9. Clamp hinges to midmounting tubes with 3/4 x 3 cap screws, 3/4 flat washers and 3/4 flex-lock nuts.

IMPORTANT: Be sure to use flex-lock nuts to clamp hinge. Tighten flex-lock nuts against hinge securely, but not to more than 125 ft.-lb. torque.

10. Secure hoses under tractor cab to avoid interference with tires or other moving parts.

11. Adjust front wheel tread settings or steering stops, if necessary to prevent interference between tires and loader. Refer to tractor operator's manual for adjustment procedures.

INSTALLING BUCKET OR ATTACHMENT

Refer to loader operator's manual to install bucket or optional attachment.

INSTALLING YOKE - 7312 LOADER



WARNING: To avoid injury during installation of quick attach loader, do not permit bystanders within ten feet of loader.

1. Loop chain under each bucket cylinder and hook on loader boom arm. Using overhead hoist to support loader remove hardware securing loader to pallet. Lift loader and remove pallet.



CAUTION: Loader uprights may rotate downward when loader is lifted from pallet.



CAUTION: Do not damage grease fitting on end of cylinder. Be sure chain does not pinch lift cylinder hose.

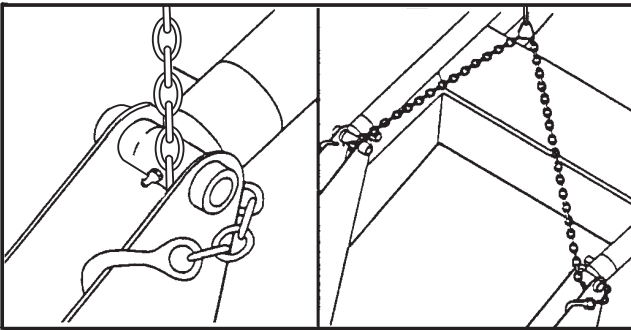

2. Position pallet at rear of loader to facilitate lowering. Lower loader from vertical shipping position to horizontal position leaving enough room to install yoke (scraps of cardboard may be used to protect paint). Install yoke to loader sideframes using 3/4 x 2-1/2 cap screws (17), 3/4 x 3-1/2 cap screws (21) and 3/4 lock nuts (13) in side holes and 5/8 x 2 cap screws (11), 5/8 x 2-1/2 cap screws (22), 5/8 flat washers (20) and 5/8 lock washers (12) in top holes. Use spacers (23 & 24) when installing with Terra Glide™ axle tractors. Lower loader to ground. Refer to figure 1 for proper yoke (16) position.

NOTE: It may be necessary to clamp sideframes together to align 5/8 inch holes in top of yoke with holes in side frames.

INSTALL HYDRAULIC KIT TO LOADER

Install hydraulics kit to loader. Refer to instruction sheet packed with kit.

MOUNTING 7312 LOADER

1. Back tractor directly behind loader facing in opposite direction.
2. Connect hoses from loader to tractor rear remotes.
3. Using overhead hoist to steady loader, slowly cycle lift and bucket cylinders several times to purge air from system. Retract cylinders and shut off engine. Replenish fluid in tractor hydraulic system.
4. Disconnect hoses from tractor. Turn tractor around and position behind loader. Secure tractor brakes.
5. Position a pair of nylon slings around upper boom directly in front of gussets. Using overhead hoist, lift loader off ground. Remove lock nut and washer from hinge and swing each hinge open.

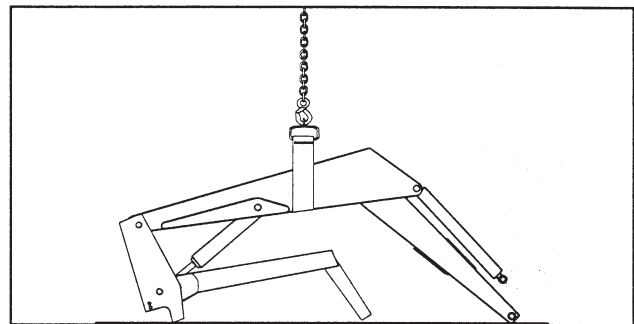

6. Block hinge open using 3/4 x 3 cap screws and 3/4 flat washers. Store 3/4 flex lock nuts on extra threads of hinge bolts.

INSTALLING 7312 LOADER TO MOUNTING BRACKETS (Continued)

- Using overhead hoist, lift loader and position on mid-mounting tubes. Move loader back until yoke tube engages front mounting bracket and hinges can clamp around midmounting tubes.

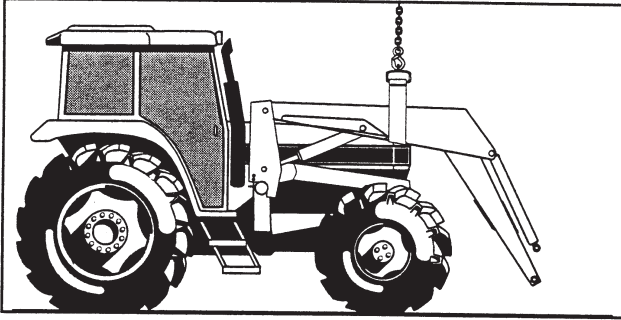

- Clamp hinges to midmounting tubes with $3/4$ x $2-3/4$ cap screws, $3/4$ flat washers and $3/4$ flex-lock nuts.

IMPORTANT: Be sure to use flex-lock nuts to clamp hinge. Tighten flex-lock nuts against hinge securely, but not to more than 125 ft.-lb. torque.

- Remove overhead hoist.
- Connect hoses to tractor hydraulics. Refer to hydraulic kit instructions for proper connections.

- Secure hoses under cab or platform to avoid interference with tires or other moving parts.
- Adjust front wheel tread settings or steering stops, if necessary to provide a minimum $3/4$ inch clearance between front tires and any part of loader with lift cylinders fully retracted and front axle fully oscillated. Be sure lift cylinders are fully retracted. Refer to tractor operator's manual for adjustment procedures.

INSTALLING BUCKET OR ATTACHMENT

Refer to loader operator's manual to install bucket or optional attachment.

INSTALLING STEP





- Center lower step (6) on loader boom crossmember.
- Place upper step (7) over boom oil line tubes, aligning holes between upper and lower steps.
- Fasten steps together using $5/16$ x $1-3/4$ cap screws (12) and $5/16$ lock nuts (15), clamping assembled step to boom crossmember.

IMPORTANT: Make sure step assembly is securely clamped to boom crossmember.

- Peel backing from anti-slip treads (8) and apply to top of bucket or bale spear.

GENERAL TORQUE SPECIFICATIONS

USE THE FOLLOWING TORQUES WHEN SPECIAL TORQUES ARE NOT GIVEN

AMERICAN STANDARD CAP SCREWS									METRIC CAP SCREWS								
SAE GRADE	5				8				METRIC GRADE	8.8				10.9			
CAP SCREW SIZE									CAP SCREW SIZE								
	TORQUE				TORQUE					TORQUE				TORQUE			
	FT.-LBS.		Nm		FT.-LBS.		Nm			FT.-LBS.		Nm		FT.-LBS.		Nm	
INCHES	MIN	MAX	MIN	MAX	MIN	MAX	MIN	MAX	MILLIMETERS	MIN	MAX	MIN	MAX	MIN	MAX	MIN	MAX
1/4 - 20	6.25	7.25	8.5	10	8.25	9.5	11	13	M6 x 1.00	6	8	8	11	9	11	12	15
1/4 - 28	8	9	11	12	10.5	12	14	16	M8 x 1.25	16	20	21.5	27	23	27	31	36.5
5/16 - 18	14	15	19	20	18.5	20	25	27	M10 x 1.50	29	35	39	47	42	52	57	70
5/16 - 24	17.5	19	23	26	23	25	31	34	M12 x 1.75	52	62	70	84	75	91	102	123
3/8 - 16	26	28	35	38	35	37	47.5	50	M14 x 2.00	85	103	115	139	120	146	163	198
3/8 - 24	31	34	42	46	41	45	55.5	61	M16 x 2.50	130	158	176	214	176	216	238	293
7/16 - 14	41	45	55.5	61	55	60	74.5	81	M18 x 2.50	172	210	233	284	240	294	325	398
7/16 - 20	51	55	69	74.5	68	75	92	102	M20 x 2.50	247	301	335	408	343	426	465	577
1/2 - 13	65	72	88	97.5	86	96	116	130	M22 x 2.50	332	404	450	547	472	576	639	780
1/2 - 20	76	84	103	114	102	112	138	152	M24 x 3.00	423	517	573	700	599	732	812	992
9/16 - 12	95	105	129	142	127	140	172	190	M27 x 3.00	637	779	863	1055	898	1098	1217	1488
9/16 - 18	111	123	150	167	148	164	200	222	M30 x 3.00	872	1066	1181	1444	1224	1496	1658	2027
5/8 - 11	126	139	171	188	168	185	228	251									
5/8 - 18	152	168	206	228	203	224	275	304									
3/4 - 10	238	262	322	355	318	350	431	474									
3/4 - 16	274	302	371	409	365	402	495	544									
7/8 - 9	350	386	474	523	466	515	631	698									
7/8 - 14	407	448	551	607	543	597	736	809									
1 - 8	537	592	728	802	716	790	970	1070									
1 - 14	670	740	908	1003	894	987	1211	1337									

NOTE: These values apply to fasteners as received from the supplier, dry or when lubricated with normal engine oil. They do not apply if special graphited or molydisulphide greases or other extreme pressure lubricants are used.

INSTALLATION INSTRUCTIONS