

**QUICK ATTACH MATERIAL BUCKETS**

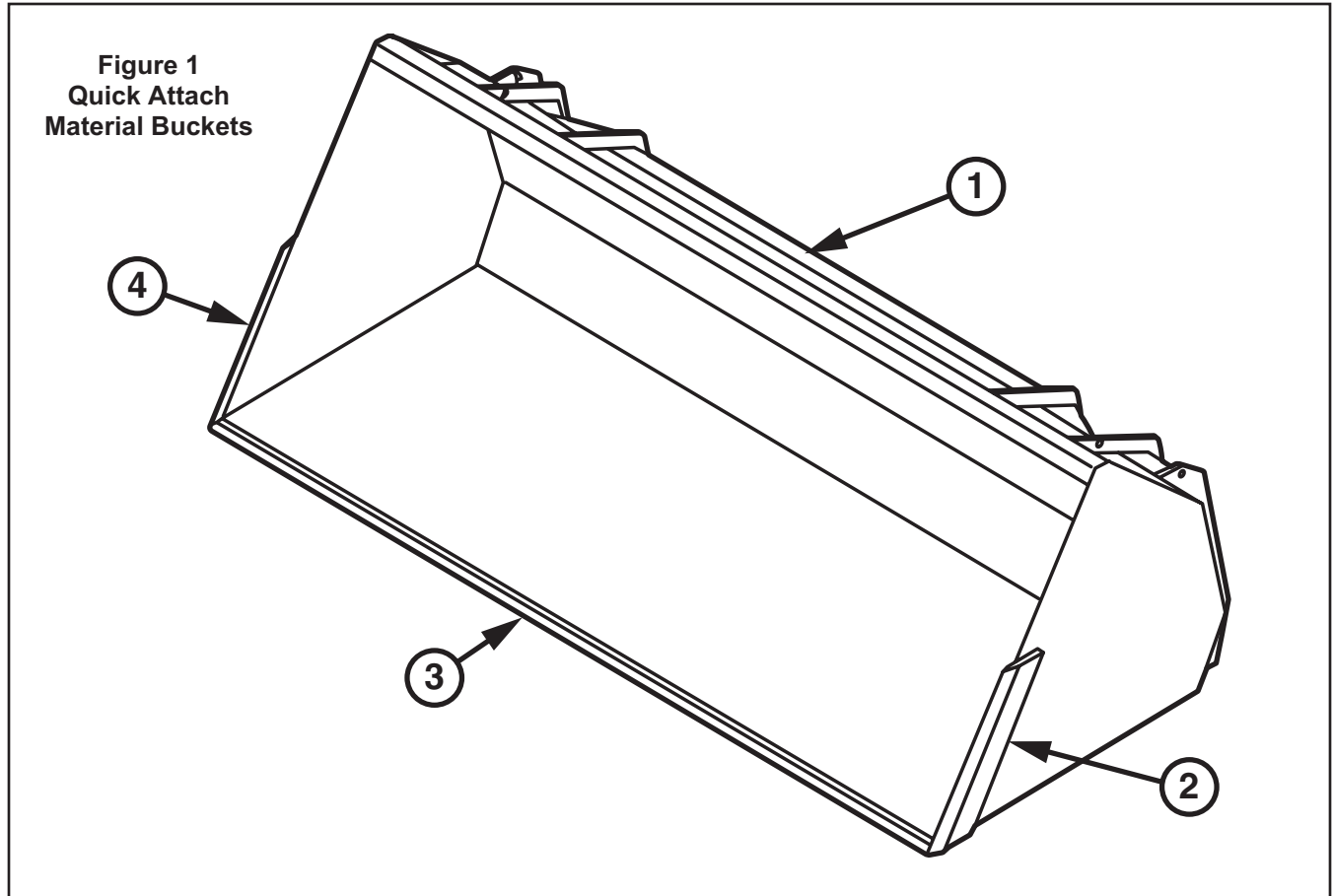

**PARTS LIST – QUICK ATTACH MATERIAL BUCKETS**

Item	SMC No.	NH No.	Description	Qty.
1	*	*	BUCKET, 72" Standard Quick Attach (Includes cutting edges.)	1
	*	*	BUCKET, 60" Heavy Duty Quick Attach (Includes cutting edges.)	1
	*	*	BUCKET, 72" Heavy Duty Quick Attach (Includes cutting edges.)	1
	*	*	BUCKET, 84" Heavy Duty Quick Attach (Includes cutting edges.)	1
	*	*	BUCKET, 84" Snow & Light Material Quick Attach (Includes cutting edges.)	1
2	28086-1	SML280861	CUTTING EDGE, Left Side (60" H.D., 72" H.D., 84" H.D., 84" Snow)	1
	32817-1	SML328171	CUTTING EDGE, Left Side (72" Standard)	1
3	22542-5	SML225425	CUTTING EDGE, Bottom (72" Standard, no holes)	1
	22543-5	SML225435	CUTTING EDGE, Bottom (60" Heavy Duty, with holes)	1
	22543-4	SML225434	CUTTING EDGE, Bottom (72" Heavy Duty, with holes)	1
	22543-3	SML225433	CUTTING EDGE, Bottom (84" Heavy Duty, with holes)	1
	22543-8	SML225438	CUTTING EDGE, Bottom (84" Snow & Light Material, no holes)	1
4	28086-2	SML280862	CUTTING EDGE, Right Side (60" H.D., 72" H.D., 84" H.D., 84" Snow)	1
	32817-2	SML328172	CUTTING EDGE, Right Side (72" Standard)	1

\* Items not sold as separate repair parts.

715729001 / 715729056 60" H.D.  
 715727001 / 715727016 72" STD.  
 715730001 / 715730056 72" H.D.  
 715737001 / 715737016 84" H.D.  
 715736001 / 715736006 84" L.D.

2-5957 / 2-6997  
 2-6052 / 2-6999  
 2-5951 / 2-7000  
 2-5952 / 2-7002  
 2-5958 / 2-7001

## ATTACHING QUICK ATTACH MATERIAL BUCKETS

No tools are needed to install quick attach material buckets. Loader must be equipped with quick attach device 715822016 (2-6983).



**WARNING:** To avoid injury during attachment or detachment, do not allow bystanders within 10 feet of loader or attachment.

1. Locate tractor and bucket on firm, level ground. Lower boom to three to five inches off ground.
2. Extend bucket cylinders slightly. Making sure loader quick attach bar is parallel to bucket, drive tractor ahead very slowly toward bucket until quick attach bar touches bucket just below attachment channel.
3. Use lift cylinder to raise loader while activating bucket cylinder to curl quick attach device to engage channel of bucket. Moving tractor forward will assist engagement. When quick attach bar has fully engaged bucket channel, continue to retract bucket cylinder until latch pins engage bucket securely.
4. Activate lift cylinder to raise bucket and extend bucket cylinders to tilt bucket at a slight downward angle, so quick attach device is visible. Visually inspect attachment mechanism to verify that pins are fully engaged in ears on back of bucket.

**NOTE:** If bucket is not securely latched, follow instructions for detaching bucket and repeat above procedure.

## DETACHING QUICK ATTACH MATERIAL BUCKETS

**IMPORTANT:** Loader must be equipped with a bucket, bale spear, or similar heavy attachment to dismount loader from tractor.



**WARNING:** To avoid injury during attachment or detachment, do not allow bystanders within 10 feet of loader or attachment.

1. Locate tractor and loader with bucket on firm level ground.
2. Lower boom arms until bucket rests level two to three inches off ground. Shut off tractor engine and set parking brake.
3. Disengage latch pins by lifting handles and rotating them so pins rest on blocks provided on attachment ears.
4. Start tractor engine, release parking brake and extend bucket cylinders while slowly backing

BUCKET MODEL	BUCKET WIDTH		STRUCK CAPACITY	
	Inches	Centimeters	Cubic Yards	Cubic Meters
72" Standard	72	183	.44	.34
60" H.D.	60	152	.44	.34
72" H.D.	72	183	.55	.42
84" H.D.	84	213	.63	.48
84" Snow & Light Material	84	213	.68	.52

# INSTALLATION INSTRUCTIONS