

Keep With Loader Operator's Manual

GRAPPLE FORK KIT FOR LOADERS EQUIPPED WITH QUICK ATTACH DEVICE (715822001 OR 2-5950)

CONTENTS

INTRODUCTION	1
OPERATION	2-4
ASSEMBLY.....	5
PLUMBING GRAPPLE FORK TO MALE QUICK COUPLERS	6
ATTACHING GRAPPLE FORK	7
PARTS LIST.....	8
GRAPPLE FORK CYLINDER SERVICE	9-10
SAFETY DECALS	11

INTRODUCTION

Grapple fork kit can be installed using tools ordinarily available. Shut off tractor engine and engage tractor brakes during installation.

Tractor must be equipped with a valve which will be available for grapple fork hydraulics or loader must be equipped with 3rd function valve kit (9863072) (2-6182).

Loader must be equipped with optional quick attach device 9843739 (Bundle 2-5950). Grapple fork can only be mounted on quick attach loader buckets.

THE FOLLOWING INTENDED USE STATEMENTS ARE SUGGESTED TO HELP PREVENT ACCIDENTS

1. Using a front end loader without special attachments for handling large heavy objects, such as large round or rectangular bales, logs, fertilizer bags and liquid containers is **NOT RECOMMENDED**.
2. Handling large heavy objects can be extremely dangerous due to:
 - Danger of tractor falling over.

- Danger of upending tractor.
 - Danger of object falling or sliding down loader arms to operator.
3. If you must perform above work, protect yourself by:
 - Using proper attachment.
 - Never lift loader higher than necessary to clear ground when moving.
 - Ballast tractor rear to compensate for load.
 - Never lift large objects with equipment that does not have an anti rollback device.
 - Move slowly and carefully avoiding rough terrain.

4. By properly balancing tractor, equipping tractor with falling object protective structure (FOPS) and exercising caution the loader with grapple fork attachment can be used to handle large round or rectangular bales and loose bulky material like hay and silage. Do not attempt to use loader to handle logs, bagged materials or liquid containers, since such use is **NOT RECOMMENDED**.

OPERATING GRAPPLE FORK

Operation of your tractor and loader with grapple fork option requires some same basic considerations as operation with a bucket, plus two new requirements: you now have to operate a grapple fork while already operating your tractor and loader; and you must also take into account additional space requirements (added length and height) needed because of attached grapple fork.

● INTENDED USE

Use of this loader without special attachments for handling large heavy objects such as large round or rectangular bales, logs, bagged material and oil drums is **NOT RECOMMENDED**.

Handling large heavy objects can be extremely dangerous due to:

- Danger of rolling tractor over.
- Danger of upending tractor.
- Danger of objects rolling or sliding down loader arms onto operator.

If you must perform any work listed above, protect yourself by:

- Never lift load higher than necessary to clear ground when moving.
- Ballast tractor rear to compensate for load.
- Never lift large objects with equipment that does not have an anti-rollback device.
- Move slowly and carefully, avoiding rough terrain.

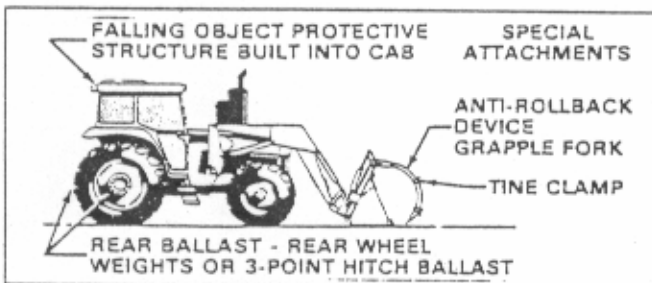

Using special attachments as shown, and exercising caution, your loader can be used to handle large round or rectangular bales and loose bulky materials like hay and silage. Do not attempt to use loader to handle logs, bagged material or liquid containers since such use is **NOT RECOMMENDED**.

NOTE: It is recommended to use both tine clamps if your grapple fork is to be used for handling round or rectangular bales. Using only one clamp may work better for loose hay or silage, allowing tines to penetrate better. Additional tine clamps are optional. Keep each grapple fork tine clamp securely fastened to grapple fork tines at all times.

● GRASPING ROUND BALES

Approach bale with grapple fork open and bucket level. Use loader float position if bale is on ground.

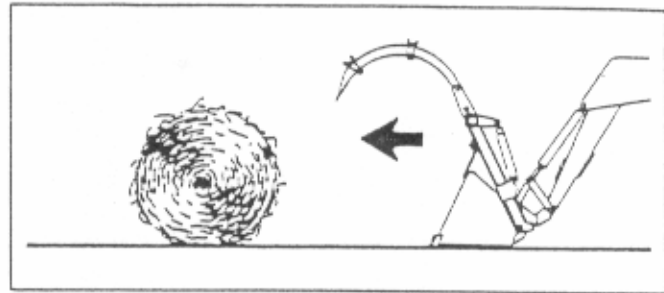

Ease valve control lever for grapple fork forward to close grapple fork around bale.

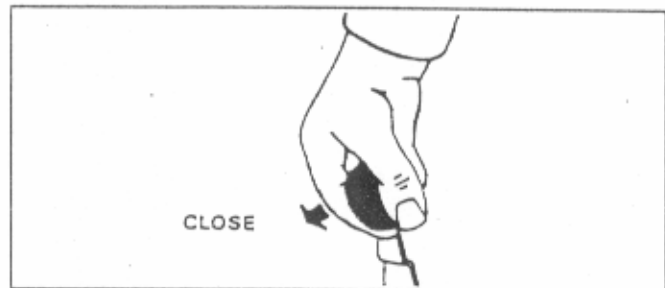

NOTE: While large round bales are best grasped as shown above, they may also be grasped from either end if necessary. **DO NOT ATTEMPT TO LIFT MORE THAN ONE LARGE ROUND BALE AT A TIME** as this can cause overloading of loader or tractor or cause unstable conditions.

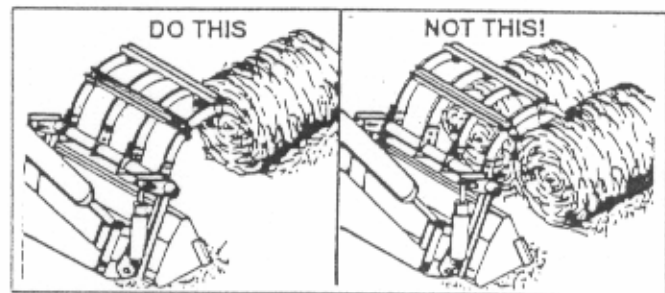

● LIFTING AND CARRYING LOAD

Ease both loader control levers back to lift and roll bucket back.

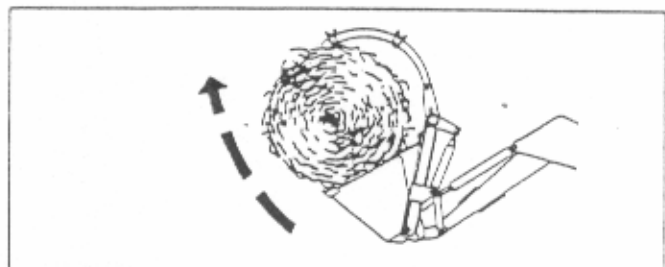

Position bucket just below level of tractor hood for maximum stability and visibility whether bucket is loaded or empty.

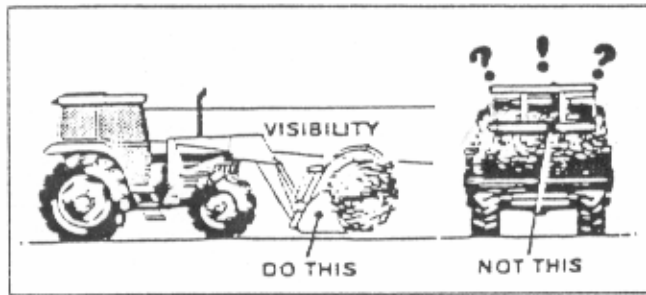

Use extreme care when operating a loader on a slope, carry load as low as possible. This keeps center of gravity for bale, tractor and loader low and will provide maximum tractor stability.

CAUTION: Operating a loader on a hillside is dangerous. Extreme care is recommended to avoid overturns.

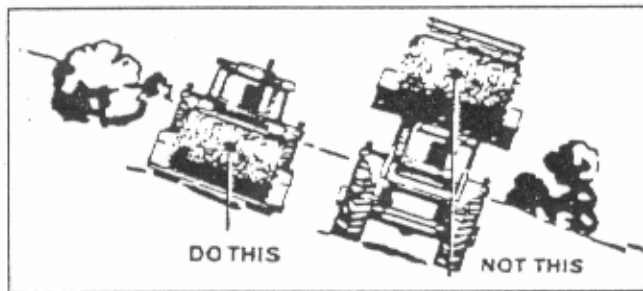

Even on level ground, transport bucket and load as low as possible to avoid tipping in case a wheel drops in a rut and to avoid power lines.

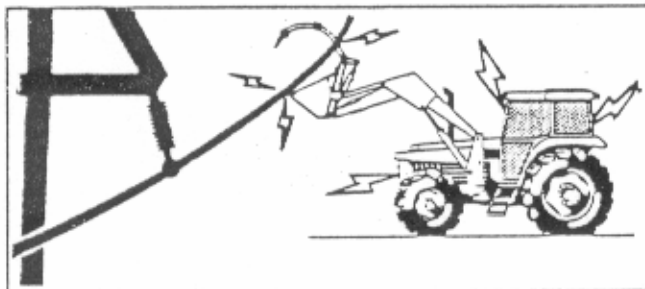

WARNING: Keep bucket, grapple fork and loader boom clear of overhead lines. Allowing loader boom or any attachments to contact overhead power lines may electrify entire tractor and electrocute (kill) operator.

● **LOADING INTO TUB GRINDER**

Lift bucket high enough to clear tub grinder sides. Move tractor toward tub grinder to position load near center. Extend bucket cylinders to position bucket in dump attitude.

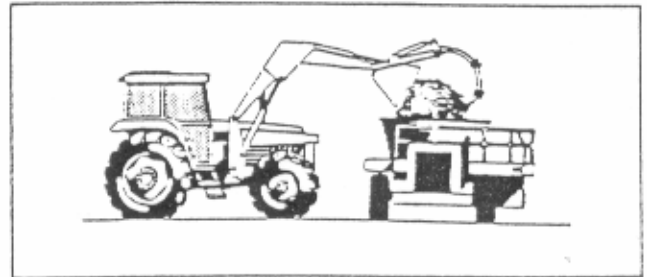

Gradually open grapple fork tines, allowing material to drop into tub grinder. For round bales, it may be necessary to gradually set bale into tub grinder to avoid shock loading tub grinder due to bale weight and to avoid sudden load on grinder mechanism.

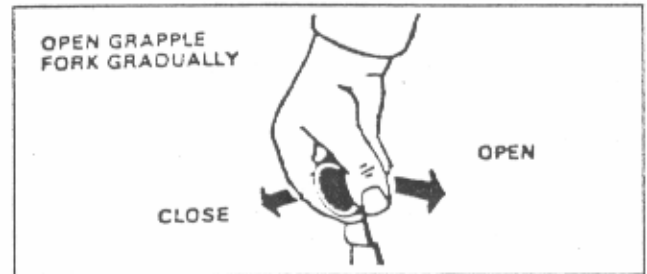

Roll bucket back, close grapple fork and back tractor away from tub grinder, then lower loader boom after dumping.

● **STACKING BALES**

WARNING: Because of size and weight of large bales, extreme care must be taken in handling them. Be aware of forces acting on stacked bales due to gravity and keep workers far from zones of potential hazard from shifting or falling bales. **DO NOT ALLOW BYSTANDERS!**

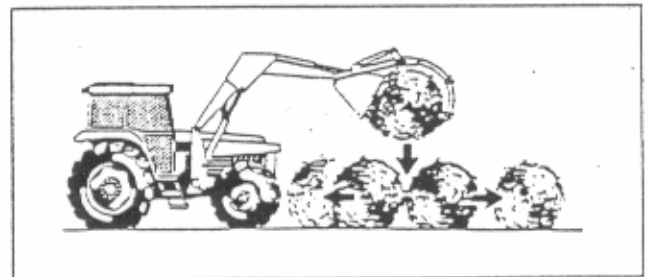

Use loader and grapple fork to gently position bale on stack, then release bale while removing bucket and fork.

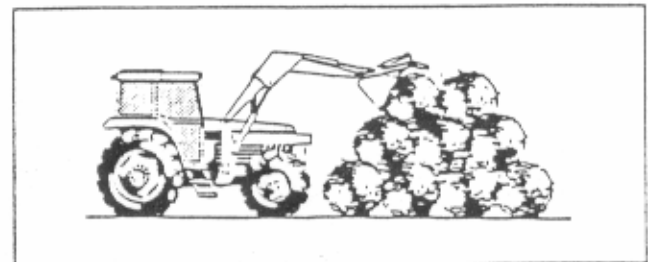

Slowly back tractor away from stack.

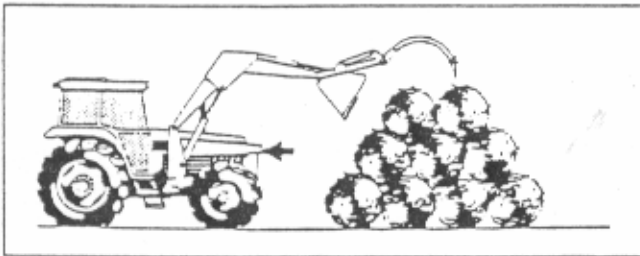

● **LOADING FROM A STACK, BUNKER SILO OR PIT SILO**

Choose forward gear that provides sufficient ground speed for loading.

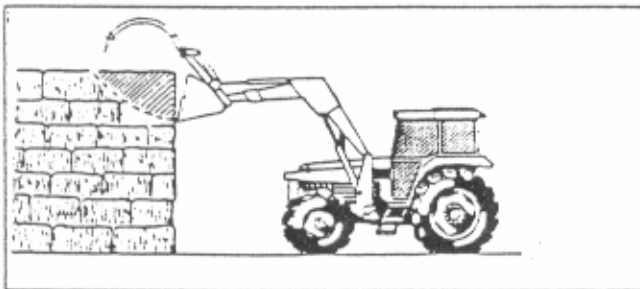

Touch pile as near as possible to top with bucket positioned in dump attitude and grapple fork open. Close grapple fork while maneuvering bucket to grasp loose material.



CAUTION: Loader lift and break-away capacity diminish as loader height is increased. Care must be taken not to grasp more material than your loader can safely support.

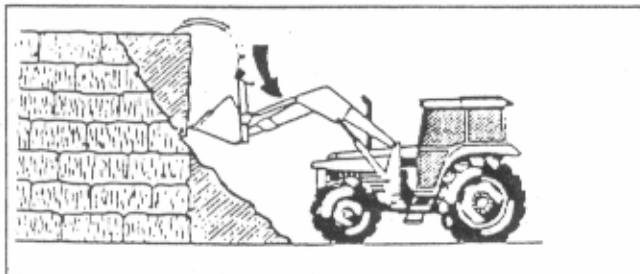

An alternate method is to use your loader and grapple fork to knock material down from top of pile so it can be loaded from ground.

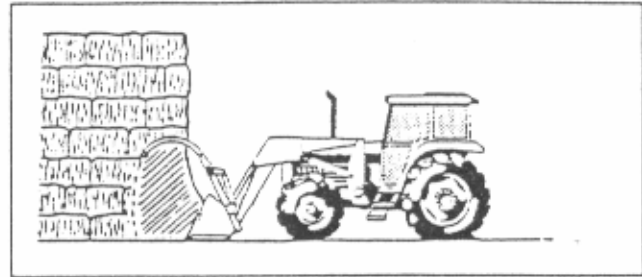

Exercise caution when undercutting a high pile. Avalanching material can be dangerous.

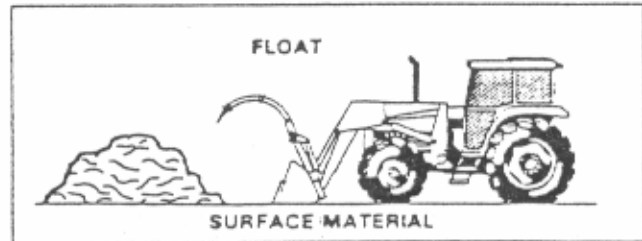

When loading material from ground, keep a level bucket and use lift control float position. If hydraulic down pressure is exerted on a bucket, it will wear faster than normal. Keep bucket level when approaching pile.

Keeping a level bucket and using loader float will reduce surface gouging and mixing surface material with stockpile material.

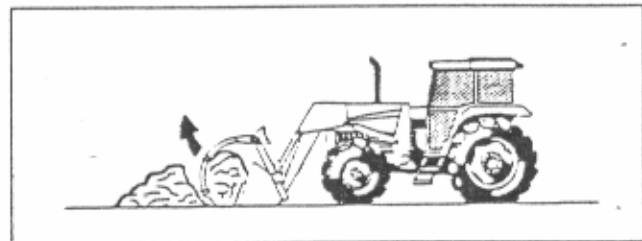

When a sufficient amount of material has accumulated in front of bucket, close grapple fork to grasp material and curl bucket.

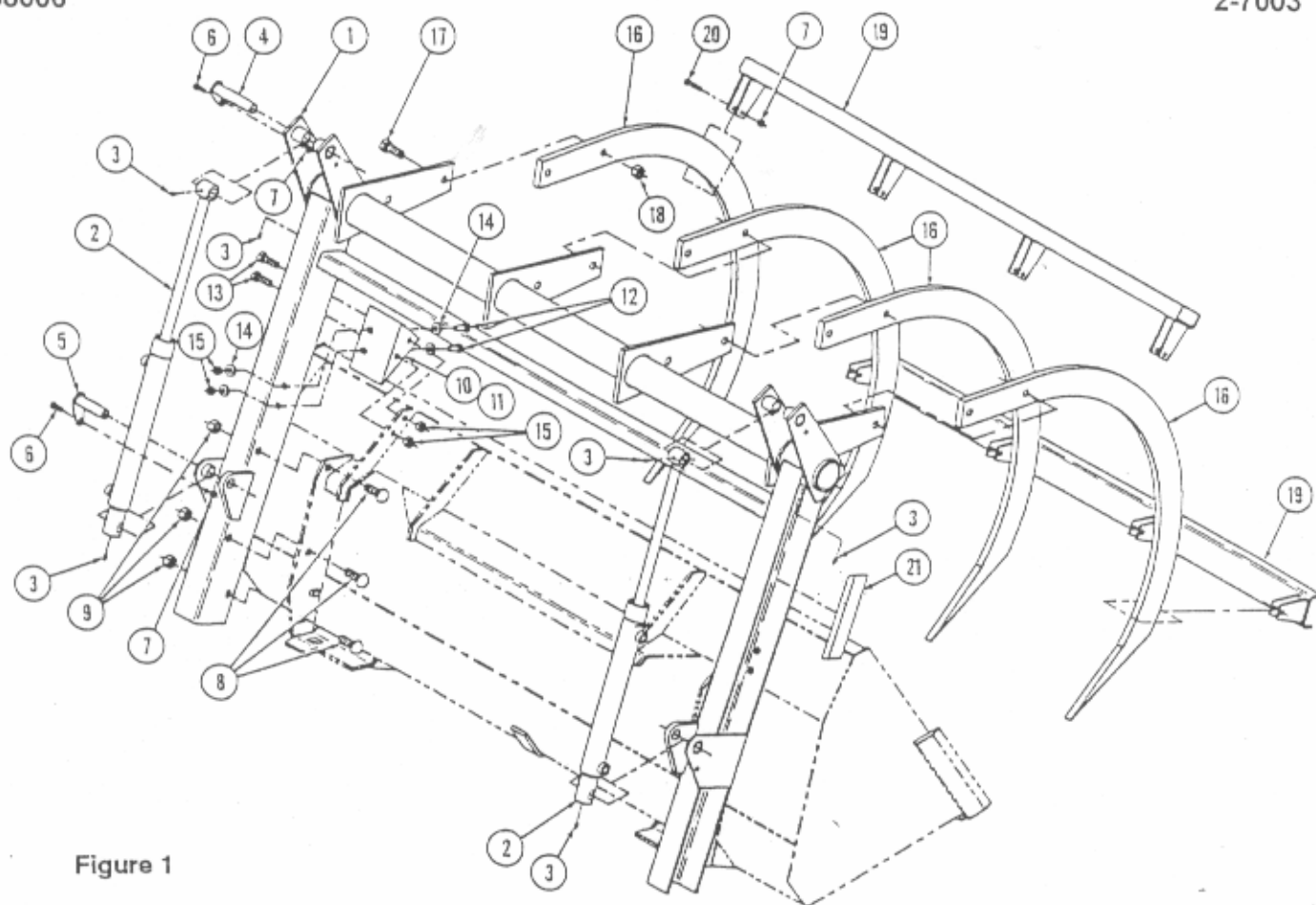

Figure 1

GRAPPLE FORK ASSEMBLY (Figure 1)

It is necessary to detach bucket from loader to install grapple fork. Follow procedure listed in "Loader Buckets" section of loader operators manual to detach bucket from loader.

1. Attach nylon slings around torque tube of grapple fork frame(1) and use an overhead hoist to raise the grapple fork frame off pallet and lower it to back of bucket. Align holes in grapple fork frame channels with holes in bucket ears and fasten grapple fork frame to bucket ears with 5/8 x 1-1/2 carriage bolts (8) and lock nuts (9).
2. Fasten left and right angle brackets (10 & 11) to bucket ears using 1/2 x 1-1/4 cap screws (13) and lock nuts (15). Use 1/2 x 1-1/2 cap screws (12), flat washers (14) and lock nuts (15) to fasten angle brackets (10 & 11) to grapple fork frame channels.
3. Attach tines (16) to tine attachment plates on grapple fork frame (1) using 3/4 x 2 cap screws (17) and lock nuts (18). Fasten outer tines to inward sides of attachment plates and fasten inner tines to outward sides. Leave hardware loose until clamp (19) is installed

4. Center one tine clamp (19) on tines and clamp it to the tines (16) using 3/8 x 1-3/4 cap screws (20) and lock nuts (7). Fasten the remaining tine clamp (19) to tines (16) near tine ends using identical hardware, unless fork will be used to handle loose, light material. Tighten all hardware.

NOTE: It is recommended to use both tine clamps if grapple fork is to be used for handling round or rectangular bales. Using only one clamp may work better for loose hay or silage, allowing tines to penetrate better. Additional tine clamps are optional.

5. Install 1/4 straight grease fittings (3) into base and rod ends of cylinders (2). Install remaining grease fittings (3) into pivot tubes near ends of grapple fork frame (1). Use grease gun to apply grease into cylinder pin connections and into pivot tube/torque tube contact surfaces.



WARNING: Keep bucket, grapple fork and loader boom clear of overhead lines. Allowing loader boom or any attachments to contact overhead lines may electrify entire tractor and kill (electrocute) operator.

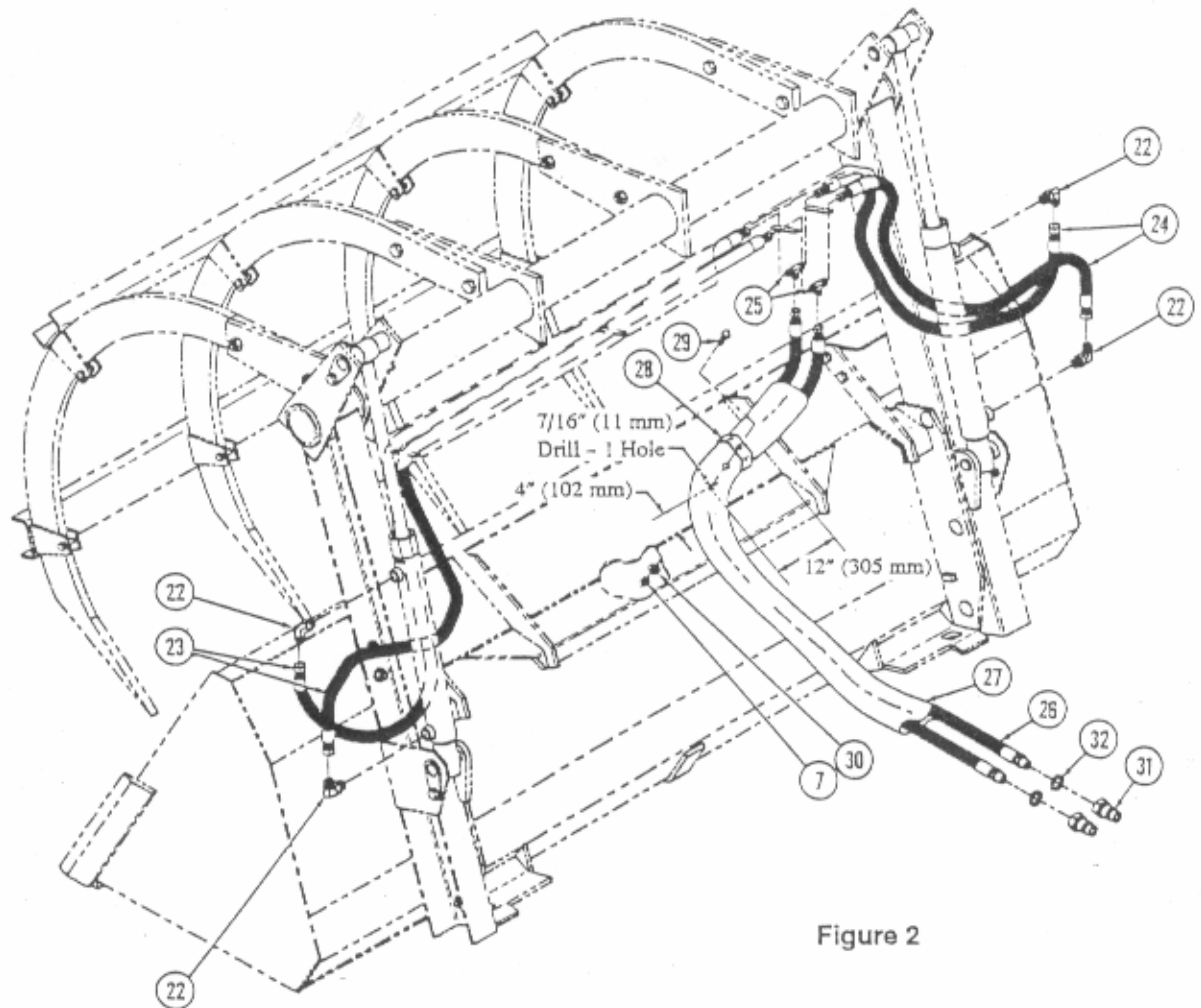

Figure 2

PLUMBING GRAPPLE FORK TO MALE QUICK COUPLERS (Figure 2)

NOTE: Apply sealant only to all tapered threads unless coupled with swivel adapters. When using teflon tape, wrap tape clockwise (as viewed from end) and wrap tape only twice. Keep sealant away from first two threads of tapered end to prevent contamination of hydraulic fluid. Do not use sealant on o-ring or flare adapter threads.

1. Remove plastic plugs from both ports of each cylinder and install 3/4 - 9/16 x 90° elbow fittings (22).
2. Connect 3/8 x 72 hoses (23) to fittings (22) in base and rod ends of left cylinder. Thread hoses (23) from left cylinder up to grapple fork cross-channel and

across toward right side of cross-channel. Connect 3/8 x 30 hoses (24) to fittings (22) in base and rod ends of right cylinder. Route hoses (24) from right cylinder up into grapple fork cross-channel to meet hoses (23) from left cylinder.

3. Use one 9/16 tee fitting (25) to connect hoses (23 & 24) from rod ends of both cylinders together. Use remaining 9/16 tee fitting (25) to connect hoses (23 & 24) from base ends of both cylinders together.
4. Install 3/8 x 90 hoses (26) onto tee fittings (25) and install male quick couplers (31) and spiral identification bands (32) onto free ends. Slide hose sleeve (27) over both hoses.

ATTACHING GRAPPLE FORK

1. Follow procedure listed in "Loader Buckets" section of loader operators manual to mount bucket onto loader.
2. Connect male quick couplers (31) from grapple fork cylinders to female quick couplers on quick coupler bracket or 3rd function selector valve mounted on loader boom cross tube.
3. After all plumbing has been completed, start tractor engine and slowly cycle grapple fork cylinders several times to purge any air out of hydraulic system, then retract cylinders and stop engine. Add additional tractor hydraulic fluid, as specified in tractor operators manual to bring oil level up to full.
4. Drill a 7/16" (11mm) hole through back of bucket approximately 12" (305 mm) toward center of bucket from right inside bucket ear and approximately 4" (102 mm) above bucket quick attach channel. To insure proper hose slack, fully dump bucket and lower to ground. Place sleeve (27) over hole with hoses (26) straddling hole to determine where hole must be to cut through sleeve (being careful not to

damage hoses). Fasten sleeve (27) and hoses (26) to bucket using oil line clamp (28), 3/8 x 1-1/2 cap screw (29), flat washer (30) and lock nut (7).

NOTE: When cycling grapple fork cylinder, pulling control lever back should open grapple fork and pushing forward should close it. If direction of control lever is reversed, lower bucket and grapple fork completely and switch hoses at boom crossmember.



WARNING: To avoid serious injury:

- Do not allow anyone within 10 feet of loader and grapple fork during operation or anytime grapple fork is in open position.
- ALWAYS keep grapple fork closed except when loading or unloading bucket.
- Before operating grapple fork, adjust hydraulic flow speed control on valve body to slowest speed setting. Refer to tractor operators manual for instructions.

GENERAL TORQUE SPECIFICATIONS

AMERICAN STANDARD CAP SCREWS									METRIC CAP SCREWS								
5					6				8.8				10.9				
TORQUE					TORQUE				TORQUE				TORQUE				
CAP SCREW SIZE	FT.-LBS.		Nm		FT.-LBS.		Nm		CAP SCREW SIZE	FT.-LBS.		Nm		FT.-LBS.		Nm	
	MIN	MAX	MIN	MAX	MIN	MAX	MIN	MAX		MIN	MAX	MIN	MAX	MIN	MAX	MIN	MAX
1/4 - 20	6.25	7.25	8.5	10	8.25	9.5	11	13	M6 x 1.00	6	8	8	11	9	11	12	15
1/4 - 28	8	9	11	12	10.5	12	14	16	M8 x 1.25	16	20	21.5	27	23	27	31	36.5
5/16 - 18	14	15	19	20	18.5	20	25	27	M10 x 1.50	29	35	39	47	42	52	57	70
5/16 - 24	17.5	19	23	26	23	25	31	34	M12 x 1.75	52	62	70	84	75	91	102	123
3/8 - 16	26	28	35	38	35	37	47.5	50	M14 x 2.00	85	103	115	139	120	146	163	198
3/8 - 24	31	34	42	46	41	45	55.5	61	M16 x 2.50	130	158	176	214	176	216	238	293
7/16 - 14	41	45	55.5	61	55	60	74.5	81	M18 x 2.50	172	210	233	284	240	294	325	398
7/16 - 20	51	55	69	74.5	68	75	92	102	M20 x 2.50	247	301	335	408	343	426	465	577
1/2 - 13	65	72	88	97.5	86	96	116	130	M22 x 2.50	332	404	450	547	472	576	639	780
1/2 - 20	76	84	103	114	102	112	138	152	M24 x 3.00	423	517	573	700	599	732	812	992
9/16 - 12	95	105	129	142	127	140	172	190	M27 x 3.00	637	779	863	1055	898	1096	1217	1488
9/16 - 18	111	123	150	167	148	164	200	222	M30 x 3.00	872	1066	1181	1444	1224	1496	1658	2027
5/8 - 11	126	139	171	188	168	185	228	251									
5/8 - 18	152	168	206	228	203	224	275	304									
3/4 - 10	238	262	322	355	318	350	431	474									
3/4 - 16	274	302	371	409	365	402	495	544									
7/8 - 9	350	386	474	523	466	515	631	698									
7/8 - 14	407	448	551	607	543	597	736	809									
1 - 8	537	592	728	802	716	790	970	1070									
1 - 14	670	740	908	1003	894	987	1211	1337									

NOTE: These values apply to fasteners as received from the supplier, dry or when lubricated with normal engine oil. They do not apply if special graphited or molydisulphide greases or other extreme pressure lubricants are used.

2-6178

715738001

2-7003

715738006

PARTS LIST - GRAPPLE FORK (Figures 1, 2 & 3)

Item	Part No.	Description	Qty.
1	40761	FRAME, Grapple Fork	1
2	40347	CYLINDER, Grapple Fork (Code IW)	2
3	6075-4	FITTING, Grease, 1/4-28 Straight	6
4	31332-8	PIN, 1 x 5	2
5	31332-4	PIN, 1 X 3-3/8	2
6	31353	BOLT, Shoulder, 3/8-16 x 1	4
7	G9413534	NUT, Lock, 3/8-16	13
8	G126382	BOLT, Carriage, 5/8-11 x 1-1/2	6
9	G9414075	NUT, Lock, 5/8-11	6
10	40772-1	BRACKET, Angle, Left	1
11	40772-2	BRACKET, Angle, Right	1
12	G180177	SCREW, Cap, 1/2-13 x 1-1/2	4
13	G180175	SCREW, Cap, 1/2-13 x 1-1/4	4
14	G120396	WASHER, Flat, 1/2	8
15	G9414074	NUT, Lock, 1/2-13	8
16	40575	TINE, Grapple Fork	4
17	G271771	SCREW, Cap, 3/4-10 x 2	8
18	G9414076	NUT, Lock, 3/4-10	8
19	40768	CLAMP, Tine	2
20	G180128	SCREW, Cap, 3/8-16 x 1-3/4	8
21	38520	DECAL, Warning: Do not allow anyone...	2
22	32845-7	FITTING, Elbow, 3/4 SAE O-Ring - 9/16 JIC Flare x 90°	4
23	36386-6	HOSE, 3/8 x 72	2
24	36386-12	HOSE, 3/8 x 30	2
25	36665-1	FITTING, Tee, 9/16 JIC Flare - 9/16 JIC Flare - 9/16 JIC Flare	2
26	38163-6	HOSE, 3/8 x 90	2
27	34853-7	SLEEVE, Nylon Hose, 84	1
28	13722	CLAMP, Hose	1
29	G180126	SCREW, Cap, 3/8-16 x 1-1/2	1
30	G120394	WASHER, Flat, 3/8	1
31	6137-4	COUPLER, Quick, Male	2
32	36240-5	BAND, Spiral, Blue	1
	36240-6	BAND, Spiral, Red	1

GRAPPLE FORK CYLINDER DISASSEMBLY (Figures 3 & 4)

1. Hold cylinder tube (13) stationary and rotate cylinder head (6) so beveled end of wire ring (14) will thread out through slot.
2. Pull shaft (1) with all assembled parts out of cylinder tube (13).

NOTE: Resistance will be felt until piston seal (11) slides over the wire retaining ring groove.

3. Remove 3/4 flange lock nut (12) from end of shaft and slide cylinder piston (9), and cylinder head (6) off the shaft.
4. Remove piston wear ring (8), piston seal (11) and o-ring (10) from out side grooves of piston (9).
5. Remove wiper seal (2), snap ring (3), reinforcing washer (4), v-pack set (5) from inside of cylinder head and o-ring (7) from groove on outside of head.
6. Clean all parts, including cylinder tube, in a suitable cleaning solvent, then use air pressure to blow any dirt or excess solvent from all parts.
7. Examine all parts for wear or damage and replace, if necessary.

GRAPPLE FORK CYLINDER ASSEMBLY

NOTE: Be careful not to damage seals, packings and o-rings on the edges or holes in cylinder tube. Inspect and remove burrs and sharp edges if necessary before reassembling.

1. Place new v-pack set (5) in head (6).

NOTE: Lips on v-pack must face toward the inside of head.

2. Place reinforcement washer (4) on top of v-pack set (5) and force down below snap ring groove.
3. Install snap ring (3) into snap ring groove

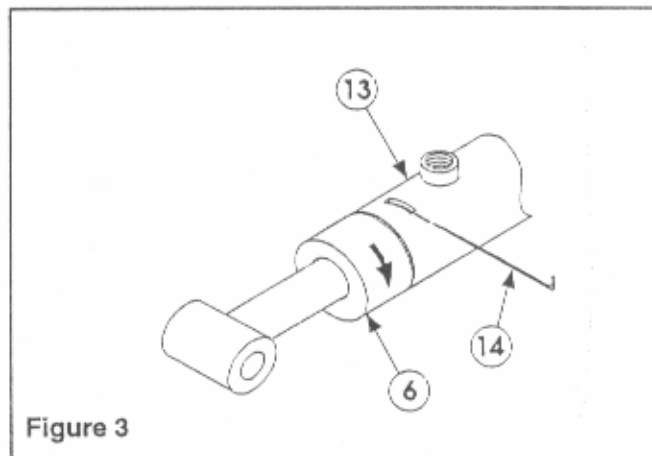

Figure 3

NOTE: Rounded outside edge of snap ring must face inward and snap ring must be firmly seated in groove.

4. Install wiper seal (2) with lip of seal facing out and flush with top of cylinder head (6).
5. Place o-ring (7) in groove on outside of head (6).
6. Remove sharp edges on outer edge of threaded end of shaft (1). Lubricate wiper seal (2) and v-packing (5) in head and carefully slide head (6) onto shaft.
7. Place o-ring (10), piston seal (11) and piston wear ring (8) in grooves on outside of piston (9).

NOTE: For easier installation, place piston seal (11) in 120° F water to warm seal.

8. Slide piston (9) onto threaded end of shaft. Install 3/4 flange lock nut (12) and tighten to 100 ft. lb. of torque.
9. Lubricate piston wear ring (8) and piston seal (11) on piston (9), o-ring (7) on head (6) and inside of cylinder tube (13) then carefully slide piston and head into cylinder tube (13).
10. Insert wire retaining ring (14) into slot in cylinder tube (13) and turn cylinder head while applying pressure to wire ring to thread it into the groove.

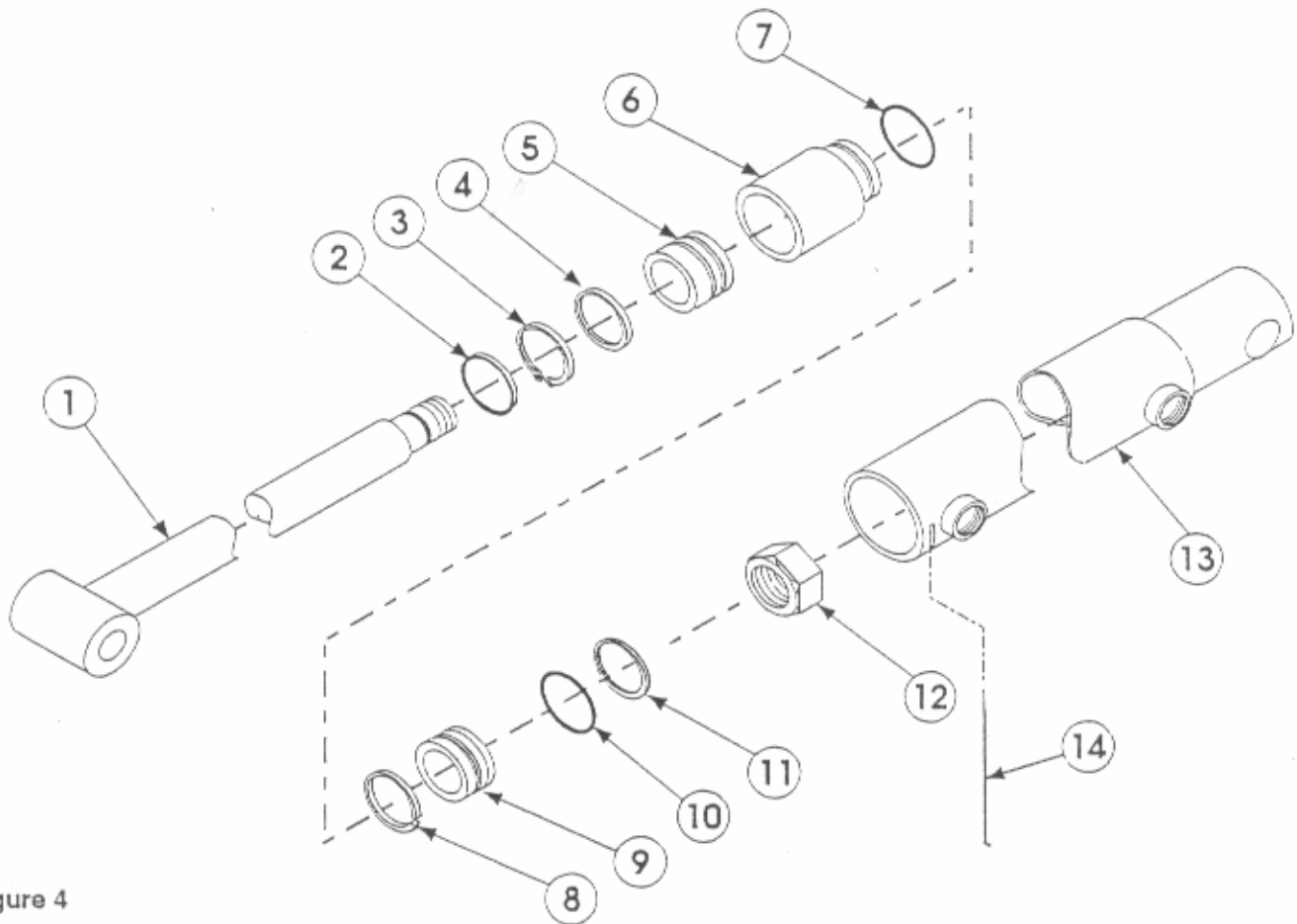

Figure 4

PARTS LIST - GRAPPLE FORK CYLINDER (40347) (Code IW)

Item	Part No.	Description	Qty.
1	40578	ROD, Weldment	1
2	*	SEAL, Wiper	1
3	*	RING, Retaining	1
4	*	WASHER, Reinforcing	1
5	*	V-PACK, Set	1
6	30566	HEAD	1
7	*	O-RING	1
8	*	RING, Wear	1
9	35936	PISTON	1
10	*	O-RING	1
11	*	SEAL, Piston	1
12	32903-1	NUT, Lock	1
13	40576	TUBE, Cylinder, Assembly	1
14	30741-1	RETAINER, Wire	1
*	36192	Repair Kit, Includes (*) Items	1

715738001

2-6178

715738006

2-7003

NOTE: Loader safety decals are at locations listed below each decal part number. Replace decals if they are damaged or illegible. Replacement decals are available from your Dealer.

 **WARNING**

TO AVOID SERIOUS INJURY

- DO NOT ALLOW ANYONE WITHIN 10 FEET OF LOADER AND GRAPPLE FORK DURING OPERATION OR ANYTIME GRAPPLE FORK IS IN OPEN POSITION.
- ALWAYS KEEP GRAPPLE FORK CLOSED EXCEPT WHEN LOADING OR UNLOADING BUCKET.
- BEFORE OPERATING GRAPPLE FORK, ADJUST HYDRAULIC FLOW SPEED CONTROL ON REMOTE CONTROL VALVE BODY TO SLOWEST SPEED SETTING. REFER TO TRACTOR OPERATOR'S MANUAL FOR INSTRUCTION.

38520

DECAL P.N. 38520

Location: Both sides of Grapple Fork Frame

2-6178

2-7003

715738001

715738006

INSTALLATION

INSTRUCTIONS