

Keep With Operator's Manual

**LOADER MOUNTING KIT  
2491 LOADER  
CASE IH & NEW HOLLAND TRACTORS**

MODEL	2WD	FWA	ROPS	CAB
Case IH DX48 & DX55	X	X	X	
New Holland TC48 & TC55DA	X	X	X	

**TRACTOR & LOADER GENERAL INFORMATION**

Mounting kit can be installed using tools ordinarily available, including a hoist capable of lifting and supporting the loader for initial mounting, standard wrenches, torque wrench, hydraulic oil, and a non-sparking drift and hammer (a shot-filled mallet is recommended).

Tractor-supplied hydraulic power is required for loader mounting and operation. Two hydraulic kits options are available for use with this loader:

2- 7431 is a mid-coupled, single- handle joystick control valve kit, which includes hoses and fittings required to plumb to tractor hydraulics.

2- 6822 is a hose kit for use with existing tractor hydraulic control valves, which includes hoses and couplings to plumb to tractor rear remote valve couplers.

If optional grille guard is to be installed, install it during front mounting bracket installation (1), before mounting loader. Refer to instructions provided with grille guard.

Check tractor tire pressure. Refer to tractor operator's manual for recommended pressures. With tractor on a firm, level surface, compare tractor rear axle height from left to right, measuring from axle center to ground. Adjust air pressure in rear tires until axle height measures same for both sides.

**NOTE:** *If rear axle on tractor is not level from side to side, cutting edge on loader bucket or similar loader-mounted attachments will not sit flat on ground.*

When loader mounting is complete, you will need to check front tire clearances and adjust tire track width as necessary.

You will also need to verify tractor wheel and axle clearances and adjust steering stops accordingly to provide clearance between front tire and tractor hood and loader on full left and right turn with front axle fully oscillated. Be sure lift cylinders are fully retracted when checking tire clearances. Refer to tractor operator's manual for steering stop adjustment.

Tractor steering stops may have to be adjusted to provide clearance between front tire and loader on full left and right turn with front axle fully oscillated. Be sure lift cylinders are fully retracted when checking tire clearances. Refer to tractor operator's manual for steering stop adjustment.

If tractor is equipped with front weights, they must be removed. The weight bracket must also be removed

Reference to left and right used in these instructions refer to position when seated in the operating position on tractor.

**PREPARING TRACTOR**

Shut off engine, engage brakes, and remove key during installation. If tractor is equipped with front weights, remove weights. It is necessary to remove weight bracket.

Remove plastic thread protectors from holes on left and right sides of tractor.

**IMPORTANT:** Clean threaded holes in tractor chassis thoroughly using a tap of proper size. Paint, rust, or debris in the threads may not permit cap screws to be installed and tightened correctly.

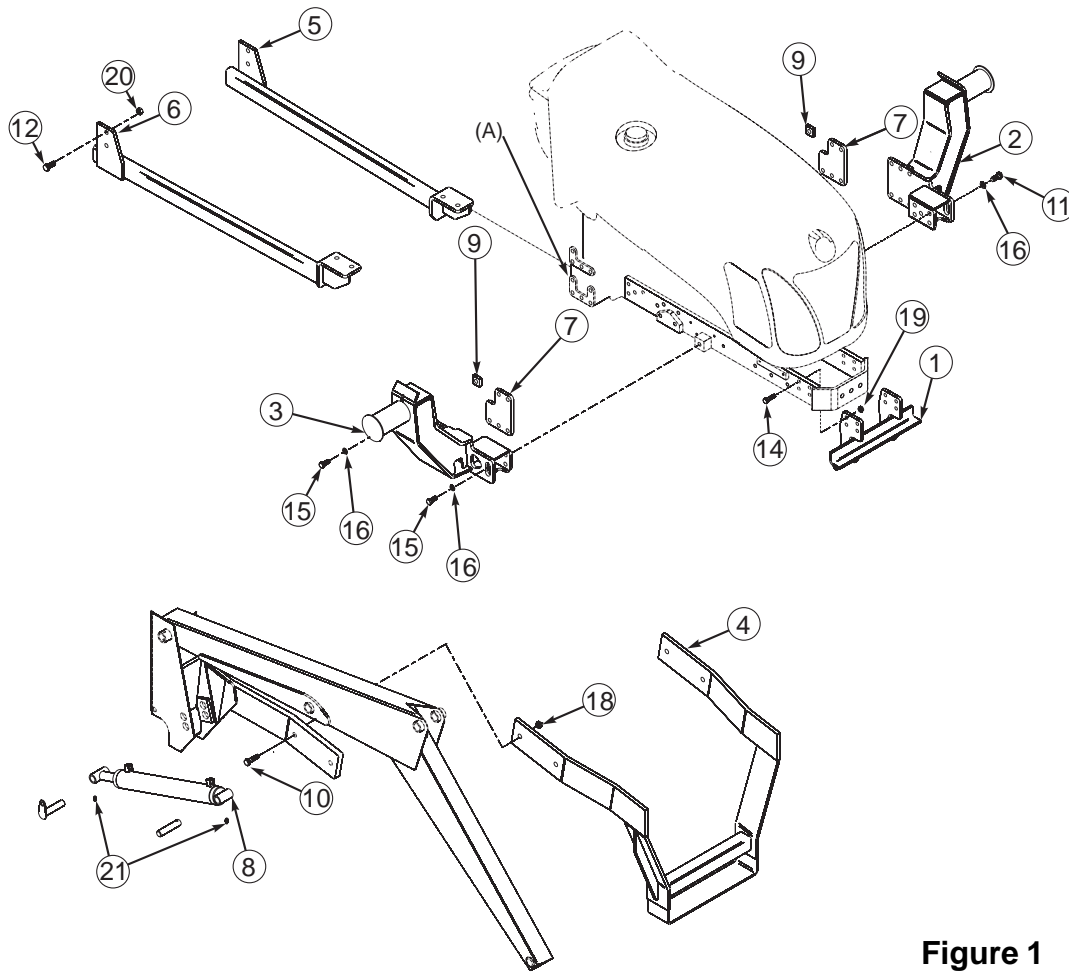

Figure 1

## PARTS LIST – MOUNTING KIT

Item	Part No.	Description	Qty.
1	51216	BRACKET, Mounting, Front	1
2	51220-1	BRACKET, Mounting, Mid, Left	1
3	51220-2	BRACKET, Mounting, Mid, Right	1
4	51213	BRACKET, Loader, Front Yoke	1
5	48929-1	BRACKET, Reinforcement, Mid to Rear, Left	1
6	48929-2	BRACKET, Reinforcement, Mid to Rear, Right	1
7	51211	SPACER, Plate, Mid Mount Flange	2
8	43129	CYLINDER, Assembly, Loader Lift, 2491, (Code JX) 2-3/8" Dia.	4
9	51210	SPACER, 1-1/2" Square x 1/2" Thick, with 11/16" hole	2
10	41838-7	SCREW, Cap, 3/4" x 2-1/2" Grade 5	4
11	41838-14	SCREW, Cap, 5/8" x 2-1/4" Grade 5	4
12	41838-32	SCREW, Cap, 5/8" x 1-3/4" Grade 5	8
13	41838-1	SCREW, Cap, 1/2" x 3-1/4" Grade 5	8
14	41838-12	SCREW, Cap, 1/2" x 1-3/4" Grade 5	8
15	42672-31	SCREW, Cap, 16mm-2 x 60mm, Class 8.8	12
16	41837-7	WASHER, Lock, 5/8"	12
17	42502-12	WASHER, Flat, 5/8"	4
18	41840-8	NUT, Lock, 3/4-10	4
19	41840-7	NUT, Lock, 5/8-11	4
20	41840-5	NUT, Lock, 1/2-13	8
21	6075-4	GREASE, Fitting, 1/4"-28 Straight	2

## INSTALLING LEFT AND RIGHT MIDMOUNTING BRACKETS AND FRONT MOUNT BRACKET (FIGURE 1)

**NOTE:** Install all attaching hardware loose until mounting kit is completely assembled, to facilitate assembly and proper alignment-unless noted otherwise. Torque all hardware to torques specified in General Torque Specifications table when assembly is complete.

1. Install front mounting bracket (1) to sides of tractor front frame using 1/2" x 1-3/4" cap screws (12), and 1/2" locknuts (13).

**NOTE:** Use 1/2" x 3-1/4" cap screws (13), instead of 1/2" x 1-3/4" cap screws (14), if grille guard is installed.

2. Remove lower 16MM cap screw securing oil line bracket (A) to mounting pad on right side of tractor. (Figure 1)

**NOTE:** If tractor is equipped with New Holland loader valve, small spacer (7) is not used for right mid mounting bracket (3). Oil line bracket sandwiches to inside of right mid mounting bracket (3), taking place of spacer. Lower 16MM bolt must be removed before installing mid mounting bracket (3).

**NOTE:** Support mid mounting brackets (2 & 3) when removing from shipping materials.

3. Raise right mid mounting bracket (3) with overhead hoist. With valve bracket or spacer (7) sandwiched between, fasten right mid mounting bracket (3) to tractor casting using 16MM x 60MM cap screws (15) and 5/8" lock washers (16) in rear four holes and 5/8" x 2-1/2" cap screws (10), 5/8" flat washers (17), and 5/8" hex lock nuts (19) in two frame holes.

4. Raise left mid mounting bracket (2) with overhead hoist. Attach left rear mounting bracket (2) to tractor casing sandwiching spacer plate (7) between. Use 16MM x 60MM cap screw (15) and 5/8" lock washers (16) in rear holes and 5/8" x 2-1/2" cap screws (10) and 5/8" flat washers (17) in two frame holes.

5. Attach rear brackets (5 & 6) to mid mounting brackets (2 & 3) and mounting ears on rear axle housing with 5/8" x 1-3/4" capscrews (14) and 5/8" hex lock nuts (19).

**NOTE:** Tighten and torque hardware to specification found in torque chart.

## INSTALLING LIFT CYLINDERS

1. Install grease fittings (8) to base and rod ends of lift cylinders (9) with fittings pointing down.



**WARNING:** Be sure to support loader using an overhead hoist. Installed lift cylinders will not support loader in upright position. Boom may fall causing serious personal injury.

2. Loop nylon strap around center of boom crossmember. Using overhead hoist to support loader, remove cap screws and pins which secure shipping braces.

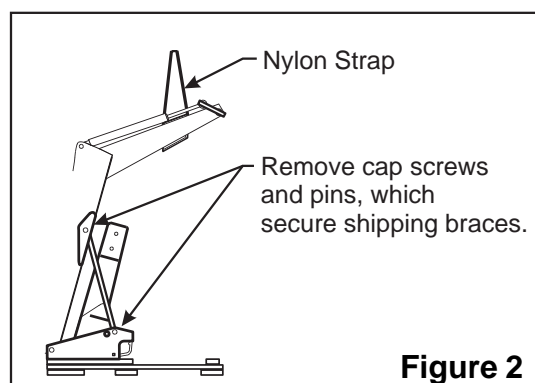

3. Install lift cylinders (8), with base end toward boom and hydraulic ports toward top, using hardware previously removed. See chart for optional cylinder placement.

**NOTE:** Pin rod end into loader upright first, then pin base end into loader boom.

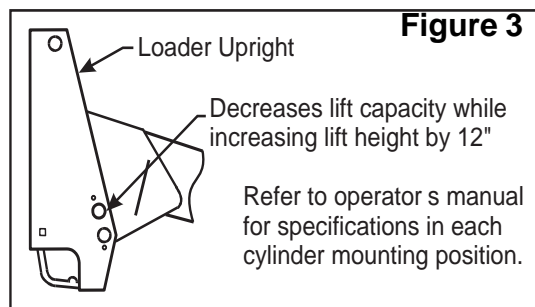

4. Disconnect lift cylinder hoses one at a time from steel oil lines to avoid error when reconnecting.

**NOTE:** Lift cylinder hoses must be free to turn while they are being connected to lift cylinders.

5. Connect hoses to lift cylinders. Reconnect hoses to steel oil lines. Make sure hoses are routed beside lift cylinder base end port to prevent crushing during loader operation.

**MOUNTING LOADER TO TRACTOR (Figures 1, 3, 4, 5, 6, 7 & 8)**



**WARNING:** Loader must be supported before removing hardware securing loader to shipping pallet, or loader will tip over.



**WARNING:** To avoid injury during installation of quick attach loader, do not permit bystanders within ten feet of loader.



**WARNING:** To avoid injury during installation of quick attach loader, an overhead hoist must be used for initial mouniing. Parking stands are not operational without bucket or heavy attachment mounted. Bale spear or pallet fork alone do not provide enough weight.

1. Attach nylon slings around loader front bumper and use an overhead hoist to support loader while removing pallet attachment brackets from loader.
2. Install yoke assembly (4) using 3/4 x 2-1/2 cap screws (10) and 3/4 lock nuts (18). Install rear cap screws first and swing yoke into position, then install front cap screws.

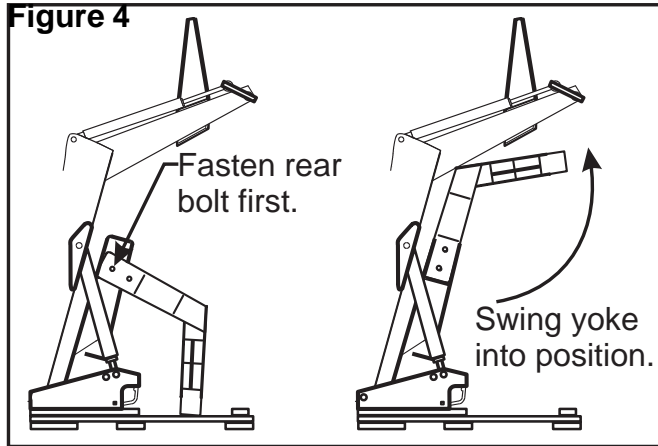

**NOTE:** Hardware connecting yoke to loader sideframes should be snug but do not torque completely. After loader has been mounted to tractor and aligned with midmounting brackets and front mounting brackets, torque hardware to 239-262 ft. lb (355 N•m).

3. Remove hardware securing loader to pallet. Using overhead hoist, lower loader from vertical shipping position to horizontal position (scraps of cardboard may be used to protect paint).

4. Install hose or valve kit to tractor and loader. Refer to assembly manual provided for installation instructions.
5. Position tractor close enough so plumbing can be connected to tractor. Shut off tractor engine and engage tractor brakes. Remove key. Route hoses loosely to allow maximum reach. Reposition overhead hoist by looping nylon straps around yoke near loader side frames at balance point of loader.
6. Using overhead hoist, raise loader until side frame uprights will clear front tires. Remove lock nut and washer from loader hinge and swing each hinge open.

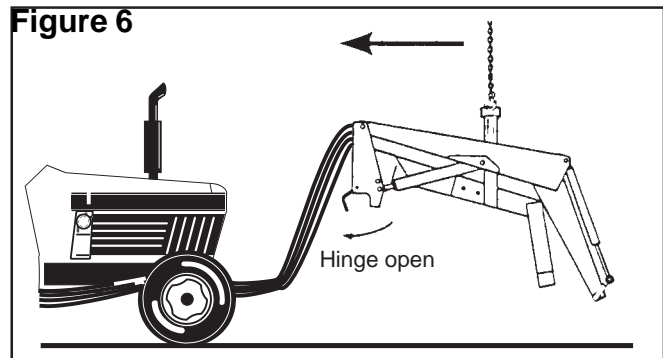
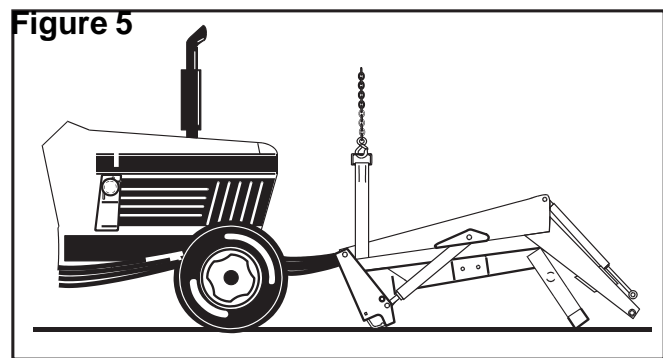

7. Position loader so hinges hook over mid mounting tubes and yoke tube fits inside front mounting bracket.

**NOTE:** To allow yoke to engage front mounting, mid mounting tube must be holding loader hinges completely open. then slide loader toward tractor until loader is seated against mid mounting tubes.

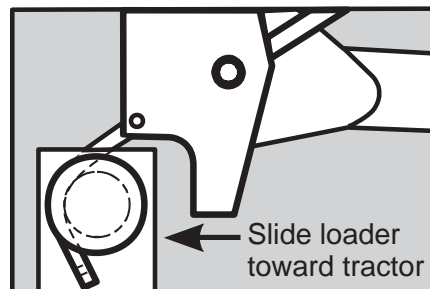
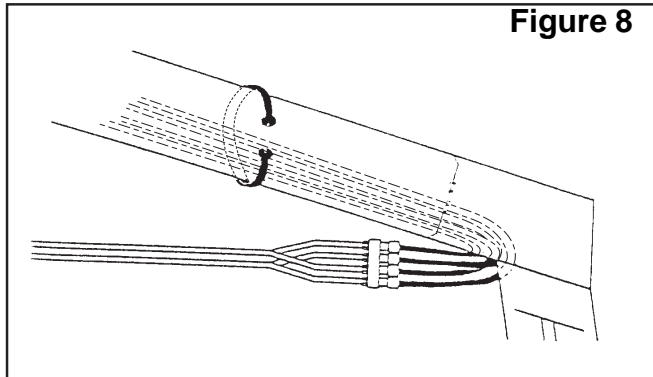

Figure 7

- Clamp hinges to midmounting tubes with 3/4 flat washers and 3/4 flex-lock nuts (supplied with loader).

**IMPORTANT:** Be sure to use flex-lock nuts to clamp hinge. Tighten flex-lock nuts against hinge securely, but not to more than 125 ft.-lb. (170 N•m) torque.

- Secure hoses behind loader side frame and yoke using rubber strap.



- Adjust front wheel tread settings or steering stops, if necessary to prevent interference between tires and loader. Refer to tractor operator's manual for adjustment procedures.

**INSTALLING BUCKET OR OPTIONAL ATTACHMENT**

Refer to loader operator's manual or optional attachment assembly instructions for procedures on installing bucket or optional attachment.

**INSTALLING BUCKET LEVEL INDICATOR**

- Attach indicator guide tube to cylinder pin. Guide tube is positioned to outside of boom for pin on attachments and inside of boom when quick attach device is used.

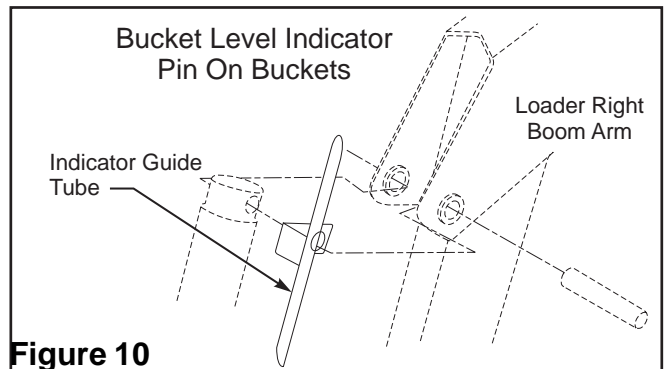
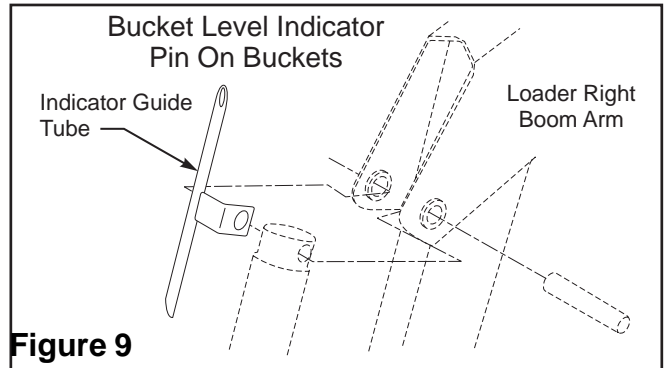

- Slide bucket level indicator rod through guide tube. Attach other end of rod with 1/8 x 1 cotter pins and 3/8 flat washers. If pin on bucket is used, attach lower end of rod to bucket ear. If quick attach device is used, attach lower end of rod to quick attach device.

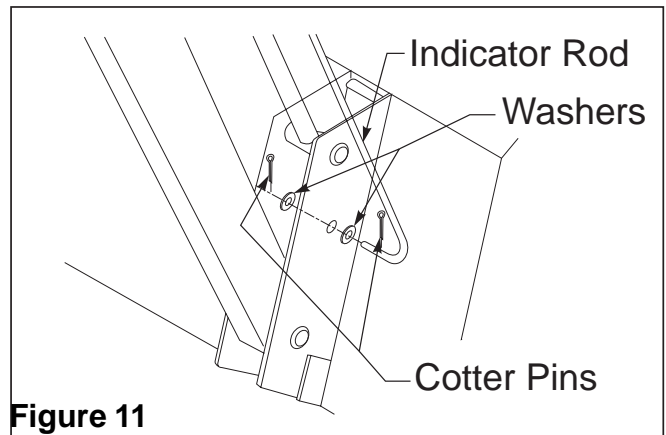

- Locate tractor and loader on level surface. With bottom of bucket resting on surface, cut off excess rod flush with end of guide tube or paint exposed rod a contrasting color.

**GENERAL TORQUE SPECIFICATIONS**

USE THE FOLLOWING TORQUES WHEN SPECIAL TORQUES ARE NOT GIVEN

**Standard American and Metric Cap Screws**

AMERICAN STANDARD CAP SCREWS										METRIC CAP SCREWS							
SAE Grade	5				8				Metric Class	8.8				10.9			
Typ. Head Markings									Typ. Head Markings								
Cap Screw	TORQUE				TORQUE				Cap Screw	TORQUE				TORQUE			
Size	FT·LBS		N·m		FT·LBS		N·m		Size	FT·LBS		N·m		FT·LBS		N·m	
Inches	MIN	MAX	MIN	MAX	MIN	MAX	MIN	MAX	Millimeters	MIN	MAX	MIN	MAX	MIN	MAX	MIN	MAX
1/4 - 20	6.25	7.25	8.5	10	8.25	9.5	11	13	M6 x 1.00	6	8	8	11	9	11	12	15
1/4 - 28	8	9	11	12	10.5	12	14	16	M8 x 1.25	16	20	21.5	27	23	27	31	36.5
5/16 - 18	14	15	19	20	18.5	20	25	27	M10 x 1.50	29	35	39	47	42	52	57	70
5/16 - 24	17.5	19	23	26	23	25	31	34	M12 x 1.75	52	62	70	84	75	91	102	123
3/8 - 16	26	28	35	38	35	37	47.5	50	M14 x 2.00	85	103	115	139	120	146	163	198
3/8 - 24	31	34	42	46	41	45	55.5	61	M16 x 2.50	130	158	176	214	176	216	238	293
7/16 - 14	41	45	55.5	61	55	60	74.5	81	M18 x 2.50	172	210	233	284	240	294	325	398
7/16 - 20	51	55	69	74.5	68	75	92	102	M20 x 2.50	247	301	335	408	343	426	465	577
1/2 - 13	65	72	88	97.5	86	96	116	130	M22 x 2.50	332	404	450	547	472	576	639	780
1/2 - 20	76	84	103	114	102	112	138	152	M24 x 3.00	423	517	573	700	599	732	812	992
9/16 - 12	95	105	129	142	127	140	172	190	M27 x 3.00	637	779	863	1055	898	1098	1217	1488
9/16 - 18	111	123	150	167	148	164	200	222	M30 x 3.00	872	1066	1181	1444	1224	1496	1658	2027
5/8 - 11	126	139	171	188	168	185	228	251	<p><b>NOTE:</b> These values apply to fasteners as received from supplier, dry or when lubricated with normal engine oil. They do not apply if special graphite or moly sulphide greases or other extreme lubricants are used.</p>								
5/8 - 18	152	168	206	228	203	224	275	304									
3/4 - 10	238	262	322	355	318	350	431	474									
3/4 - 16	274	305	371	409	365	402	495	544									
7/8 - 9	350	386	474	523	466	515	631	698									
7/8 - 14	407	448	551	607	543	597	736	809									
1 - 8	537	592	728	802	716	790	970	1070									
1 - 14	670	740	908	1003	894	987	1211	1337									

# INSTALLATION INSTRUCTIONS