

## BACKHOE SKID-STEER ADAPTER KIT 95 BACKHOES CASE 40XT, 60 & 70XT SKID-STEER LOADERS

Adapter kit can be installed using tools ordinarily available.

Reference to left and right used in these instructions refer to position when seated in the operating position on skid-steer.

Adapter kit consists of a middle link bracket that bolts to skid-steer loader. Another quick attach adapter bolts to backhoe. A middle link pins between backhoe and middle link bracket on skid-steer loader. This center link prevents skid-steer loader boom from raising and prevents skid-steer bucket cylinders from tilting when backhoe is in use. To raise and/or tilt backhoe to get over an obstruction, middle link must be unlatched from skid-steer.



**WARNING:** *To avoid injury while mounting or dismounting backhoe from skid-steer, do not allow bystanders within ten feet of skid-steer or backhoe.*

Lower and level skid-steer boom to rest on ground before installing adapter kit and backhoe. Shut off engine and engage brakes during installation.

### INSTALLING MIDDLE LINK BRACKET TO SKID-STEER LOADER (Figure 1)

Fasten middle link bracket (2) to skid-steer loader using 1/2 x 1-1/4" cap screws (11) and lock nuts (13), and 5/8 x 1-1/2" cap screws (8) and lock nuts (9). Tighten bolts to torques specified in general torque specifications table.

### INSTALLING QUICK ATTACH ADAPTER TO BACKHOE

Fasten quick attach adapter (1) to backhoe using 3/4" x 2-1/4" cap screws (10), 3/4" lock nuts (14). Torque hardware to torques specified in general torque specifications table.

### INSTALLING MIDDLE LINK TO BACKHOE

Pin middle link (3) to backhoe upper 3-point pin point using 3/4" x 3-7/8" clevis pin (15) and 1/4" x 1-1/2" cotter pin (17). Install latch handle (4) into middle link (3) using

1" x 2-1/2" clevis pin (16), 1" x 1-1/2" machinery bushing (19) and 3/16" x 1-1/2" cotter pin (18). Use machinery bushing (19) on each side of latch handle (4) inside center link (3) and one outside. Use 3/4 x 3" pin (7) and linch pin (20) to secure latch handle (4) open, so middle link (3) can hook over pin in middle link bracket (2) on skid-steer. Later this same 3/4 x 3" pin (7) will be used to secure latch handle (4) in latched position.

### INSTALLING SHIMS ON MIDDLE LINK

After hooking backhoe and middle link (3) onto skid-steer and with skid-steer boom completely lowered, note how much space is between middle link (3) and top of cross tube in quick attach adapter (1). Place an appropriate number of shims (5 & 6) between middle link (3) and cross tube to eliminate most of this gap. Do not place too many shims in this gap so hook on middle link (3) does not completely set down on pin in middle link bracket (2) on skid-steer. Shims are intended only to take up some space and reduce movement of backhoe relative to skid-steer loader. Fasten shims to bottom of middle link (3) using 3/8" x 1-1/2" cap screws (12) and lock nuts (21).

### ATTACHING BACKHOE TO SKID-STEER

1. Engage skid-steer quick-attach into backhoe adapter. Lift backhoe with skid-steer boom so adapter middle link (3) clears skid-steer middle link bracket (2). Tilt skid-steer quick attach back to near vertical position and engage latch pins to secure backhoe to skid-steer. If backhoe is too heavy for skid steer to tilt it back, see instruction 2, below.
2. Lower backhoe boom to ground and put backhoe boom control lever into float position (push left lever forward into detent position) to reduce weight on backhoe frame and skid-steer. Relieve pressures inside backhoe valve by working handles back and forth. Shut off skid-steer and connect hydraulic quick couplers to skid-steer.

*Continued on page 2*

**2-7212**  
**2-7213**

**ATTACHING BACKHOE TO SKID-STEER**  
**(Continued)**

3. Turn on skid-steer auxiliary quick couplers to send oil flow to backhoe. Lift backhoe stabilizers slightly off ground. Tilt backhoe slightly forward using loader bucket cylinders and lower skid-steer boom completely down. Tilt backhoe rearward using loader bucket cylinders until middle link (3) is seated onto pin in middle link bracket (2).
4. When middle link is completely seated onto pin, rotate middle link latch handle (4) into latched position and pin with 3/4 x 3" pin (7) and linch pin (20).
5. From backhoe seat, operate backhoe boom control lever out of float position. Put backhoe into transport position to transport to work site.

**REMOVING BACKHOE FROM SKID-STEER**

1. With backhoe boom straight back, extend dipperstick completely out, lower backhoe boom and bucket to ground and put boom control lever into float position. Install lock pin in swing bracket so boom cannot rotate.
2. Make sure skid-steer boom is completely lowered. Tilt forward and back with skid-steer bucket cylinders

until middle link latch handle (4) loosens. Remove 3/4 x 3" pin (7) from middle link latch handle (4), open latch handle (4) and reinstall 3/4 x 3" pin (7) to hold latch handle open.

3. Lift straight up with skid-steer boom until middle link hook clears skid-steer middle link bracket pin. Some slight adjustments may have to be made with skid-steer bucket cylinders if hook hangs up on pin.
4. From backhoe seat, operate backhoe boom control handle out of float position to center, neutral position.

**IMPORTANT:** For proper support of dismounted backhoe, operate backhoe boom control handle out of float position to center, neutral position.

5. Lower stabilizers to ground to support detached backhoe.
6. From skid-steer, unlock skid-steer quick-attach latching pins. Tilt skid-steer quick-attach adapter forward, lower boom and back skid-steer slightly away from backhoe.
7. Lower backhoe to ground by pulling backhoe valve lever to raise stabilizers. Shut off skid-steer. Work skid-steer auxiliary quick coupler valve back and forth to remove pressure in backhoe and skid-steer lines. Uncouple hydraulic hoses.

**PARTS LIST - BACKHOE SKID-STEER ADAPTER KIT**

Item	Part No.	Description	Qty.
1	49291	BRACKET, Backhoe Quick-Attach Adapter	1
2	50745	BRACKET, Middle Link Plate	1
3	50754	MIDDLE LINK (Model 40XT)	1
	50752	MIDDLE LINK (Model 60XT & 70XT)	1
4	50743	HANDLE, Latch, Middle Link (Model 40XT)	1
	50741	HANDLE, Latch, Middle Link (Model 60XT & 70XT)	1
5	49319-1	SHIM (10 Gauge)	2
6	49319-2	SHIM (7 Gauge)	1
7	49328	PIN, 3/4 x 3"	1
8	41838-29	SCREW, Cap, 5/8-11 x 1-1/2", Grade 5	2
9	41840-7	NUT, Lock, 5/8-11	2
10	41838-15	SCREW, Cap, 3/4-10 x 2-1/4", Grade 5	6
11	41838-2	SCREW, Cap, 1/2-13 x 1-1/4", Grade 5	8
12	41838-23	SCREW, Cap, 3/8-16 x 1-1/2", Grade 5	2
13	41840-5	NUT, Lock 1/2-13	8
14	41840-8	NUT, Lock 3/4-10	6
15	41902-2	PIN, Clevis, 3/4 x 3-7/8"	1
16	41902-4	PIN, Clevis, 1 x 2-1/2"	1
17	41903-13	PIN, Cotter, 1/4 x 1-1/2"	1
18	41903-8	PIN, Cotter, 3/16 x 1-1/2"	1
19	42577-5	BUSHING, Machinery 1 x 1-1/2"	4
20	44756-1	PIN, Linch, 5/16 x 1-5/8"	1
21	41840-3	NUT, Lock, 3/8-16	2



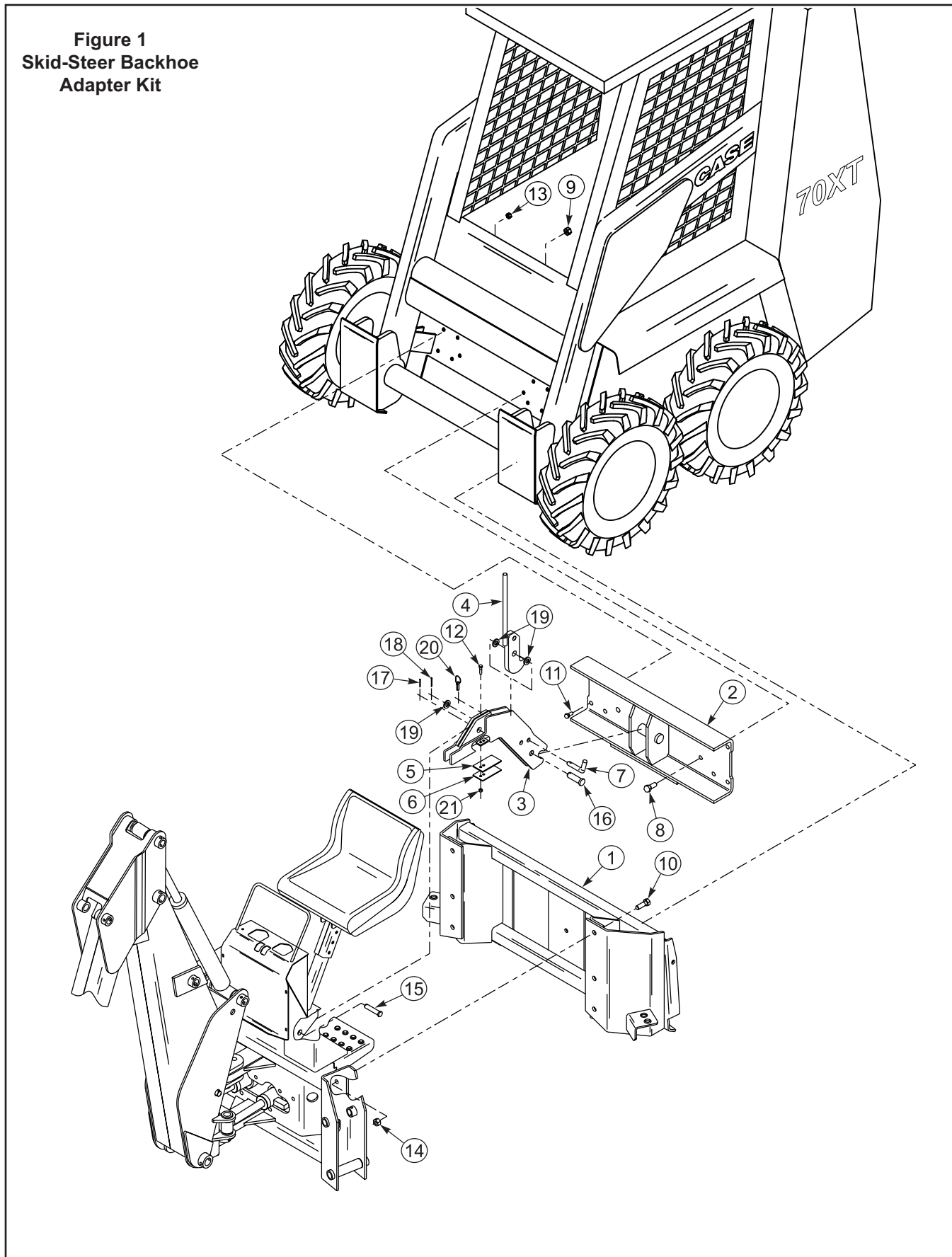

**Figure 1**  
**Skid-Steer Backhoe**  
**Adapter Kit**



**GENERAL TORQUE SPECIFICATIONS**

USE THE FOLLOWING TORQUES WHEN SPECIAL TORQUES ARE NOT GIVEN

**Standard American and Metric Cap Screws**

AMERICAN STANDARD CAP SCREWS										METRIC CAP SCREWS								
SAE Grade	5				8				Metric Class	8.8				10.9				
Typ. Head Markings									Typ. Head Markings									
Cap Screw	TORQUE				TORQUE				Cap Screw	TORQUE				TORQUE				
Size	FT·LBS		N·m		FT·LBS		N·m		Size	FT·LBS		N·m		FT·LBS		N·m		
Inches	MIN	MAX	MIN	MAX	MIN	MAX	MIN	MAX	Millimeters	MIN	MAX	MIN	MAX	MIN	MAX	MIN	MAX	
1/4 - 20	6.25	7.25	8.5	10	8.25	9.5	11	13	M6 x 1.00	6	8	8	11	9	11	12	15	
1/4 - 28	8	9	11	12	10.5	12	14	16	M8 x 1.25	16	20	21.5	27	23	27	31	36.5	
5/16 - 18	14	15	19	20	18.5	20	25	27	M10 x 1.50	29	35	39	47	42	52	57	70	
5/16 - 24	17.5	19	23	26	23	25	31	34	M12 x 1.75	52	62	70	84	75	91	102	123	
3/8 - 16	26	28	35	38	35	37	47.5	50	M14 x 2.00	85	103	115	139	120	146	163	198	
3/8 - 24	31	34	42	46	41	45	55.5	61	M16 x 2.50	130	158	176	214	176	216	238	293	
7/16 - 14	41	45	55.5	61	55	60	74.5	81	M18 x 2.50	172	210	233	284	240	294	325	398	
7/16 - 20	51	55	69	74.5	68	75	92	102	M20 x 2.50	247	301	335	408	343	426	465	577	
1/2 - 13	65	72	88	97.5	86	96	116	130	M22 x 2.50	332	404	450	547	472	576	639	780	
1/2 - 20	76	84	103	114	102	112	138	152	M24 x 3.00	423	517	573	700	599	732	812	992	
9/16 - 12	95	105	129	142	127	140	172	190	M27 x 3.00	637	779	863	1055	898	1098	1217	1488	
9/16 - 18	111	123	150	167	148	164	200	222	M30 x 3.00	872	1066	1181	1444	1224	1496	1658	2027	
5/8 - 11	126	139	171	188	168	185	228	251	<p><b>NOTE:</b> These values apply to fasteners as received from supplier, dry or when lubricated with normal engine oil. They do not apply if special graphite or moly sulphide greases or other extreme lubricants are used.</p>									
5/8 - 18	152	168	206	228	203	224	275	304										
3/4 - 10	238	262	322	355	318	350	431	474										
3/4 - 16	274	305	371	409	365	402	495	544										
7/8 - 9	350	386	474	523	466	515	631	698										
7/8 - 14	407	448	551	607	543	597	736	809										
1 - 8	537	592	728	802	716	790	970	1070										
1 - 14	670	740	908	1003	894	987	1211	1337										

# INSTALLATION INSTRUCTIONS