

Keep With Operator's Manual

**LOADER MOUNTING KIT  
4211 STD & MSL LOADER  
CASE-IH JX55 & JX65**

MODEL	2WD	FWA	CAB	LESS CAB
JX55	X	X	X	X
JX65	X	X	X	X

“MSL” refers to mechanical self leveling.

Mount kit can be installed using tools ordinarily available.

**NOTE:** Leave all attaching hardware loose until loader is completely assembled to facilitate assembly and proper alignment. Torque all hardware to specifications listed in loader operator's manual.

**TRACTOR PREPARATION**

1. Shut off engine and engage brakes during installation of mounting kit.
2. If tractor is equipped with front weights, they should be removed.
3. Toolbox needs to be removed.
4. Loader mounting is not compatible with front fenders.
5. Tractor steering stops must be adjusted to provide a minimum of 3/4" between front tire and loader or mountings on full left or right turn with front axle fully oscillated. Adjustment must be made with lift cylinders fully retracted. Refer to tractor operators manual for steering stop adjustment.

**INSTALLING RIGHT MID MOUNTING**

1. Remove three 16MM cap screws securing cab/platform support to transmission casting. Remove spacer blocks between cab/platform support and tractor transmission casting. Retain hardware for future use.
2. Place a straight clevis over top inside bushing at top of right midmounting assembly (2) and secure. Using an overhead hoist, hook to clevis and raise right midmounting (2) into position. Slide rear of mounting between tractor casting and cab/platform support bracket. Install rear of right midmounting (2) to tractor transmission casting using 16MM hardware removed to remove spacer blocks. Install shorter bolts in upper two holes and longer bolt in lower rear hole. Install 16MM x 100MM cap screw (10), 5/8" flat washer (12), and 5/8" lock washer (11) in lower front hole of four bolt pattern at rear of midmounting.

3. Attach front of mid mounting using 16MM x 100MM cap screws (10), 5/8" flat washer (12), 5/8" lock washers (11), spacer tubes (7 & 8), and spacer plate (9) as shown in Figure 1. If tractor is equipped with a grille guard, spacer plate (9) is removed and replaced by the grille mounting plate.

**INSTALLING LEFT MID MOUNTING**

1. Remove exhaust stack. Remove exhaust tube from muffler to exhaust bracket. Remove exhaust bracket. Install spacer (15) in place of exhaust bracket, using hardware removed to remove exhaust bracket.
2. Place floor jack under front, inside corner of fuel tank to support fuel tank. Remove bolts securing flat support to bottom side of transmission casting. Remove 8MM hardware securing flat support to step. Remove 16MM hardware securing cab/platform support to transmission casting and remove and discard spacer blocks.

**NOTE:** Remove lower long bolt first, lower fuel tank slightly and have helper pull tank out slightly to remove lower bolt. Now you can access upper two bolts with tank lowered for their removal.

3. Install clevis over top of inside bushing of left mid mounting (1) and secure. Using an overhead hoist, hook to clevis and raise left mid mounting (1) into position. Slide rear of mounting between tractor transmission casting and cab/platform support bracket. Install rear of left midmounting (1) to transmission casting using 16MM hardware removed to remove spacer blocks. Install shorter bolts in upper two holes and longer bolt in lower rear hole. Install 16MM x 100MM cap screw (10), 5/8" flat washer (12), and 5/8" lock washer in lower front hole of four bolt pattern at rear of mid mounting.
4. Attach front of left mid mounting (1) using 16MM x 100MM cap screws (10), 5/8" flat washers (12), 5/8" lock washers (11), spacers tubes (7 & 8), and spacer plate (9) as shown in Figure 1. If tractor is equipped with a grille guard, spacer plate (9) is removed and replaced by the grille mounting plate.

## 2-7291

### INSTALLING LEFT MID MOUNTING (CONTINUED)

5. Torque M16 hardware to 142 ft.-lbs. Torque other hardware to torques specified on torque chart in loader operators manual.
6. Slide fuel tank back into place. Reinstall fuel tank flat support to bottom side of transmission casting. Reinstall 8MM hardware securing flat support to left step.
7. Install exhaust bracket assembly (3) onto left mid mounting (1) using 1/2" x 1 1/2" cap screws (5) and 1/2" nuts (6). Install exhaust tube (4) onto muffler and turn into place at exhaust bracket. Install exhaust stack over exhaust tube. Use clamp and hardware removed when removing original exhaust tube to fasten to exhaust bracket assembly (4).
8. Install loader plumbing kit.

### PARTS LIST - MOUNTING KIT

Item	Part No.	Description	Qty.
1	51497-1	MID MOUNTING ASSEMBLY, Left w/decals	1
2	51497-2	MID MOUNTING ASSEMBLY, Right w/decals	1
3	51481	BRACKET ASSEMBLY, Exhaust	1
4	51480	TUBE, Exhaust	1
5	51479	SPACER	1
6	51518-1	SPACER TUBE	4
7	51518-2	SPACER TUBE	4
8	51491	SPACER, Front	2
9	48858	DECAL, Danger	1
10	23487-2	FITTING, Elbow, 1/2"-14 x 1/2"-14	4
11	42672-28	SCREW, Cap, 16MM-1.50 x 100MM	10
12	41837-7	WASHER, Lock, 5/8	10
13	42502-32	WASHER, Flat, 5/8", W-STD	10
14	41838-33	SCREW, Cap, 1/2"-13 x 1.50	2
15	41836-5	NUT, Hex, 1/2"-13	7
16	48436	DECAL, Warning	1
17	46776	DECAL, Warning	1

**Figure 1**  
**Loader Mounting Kit**

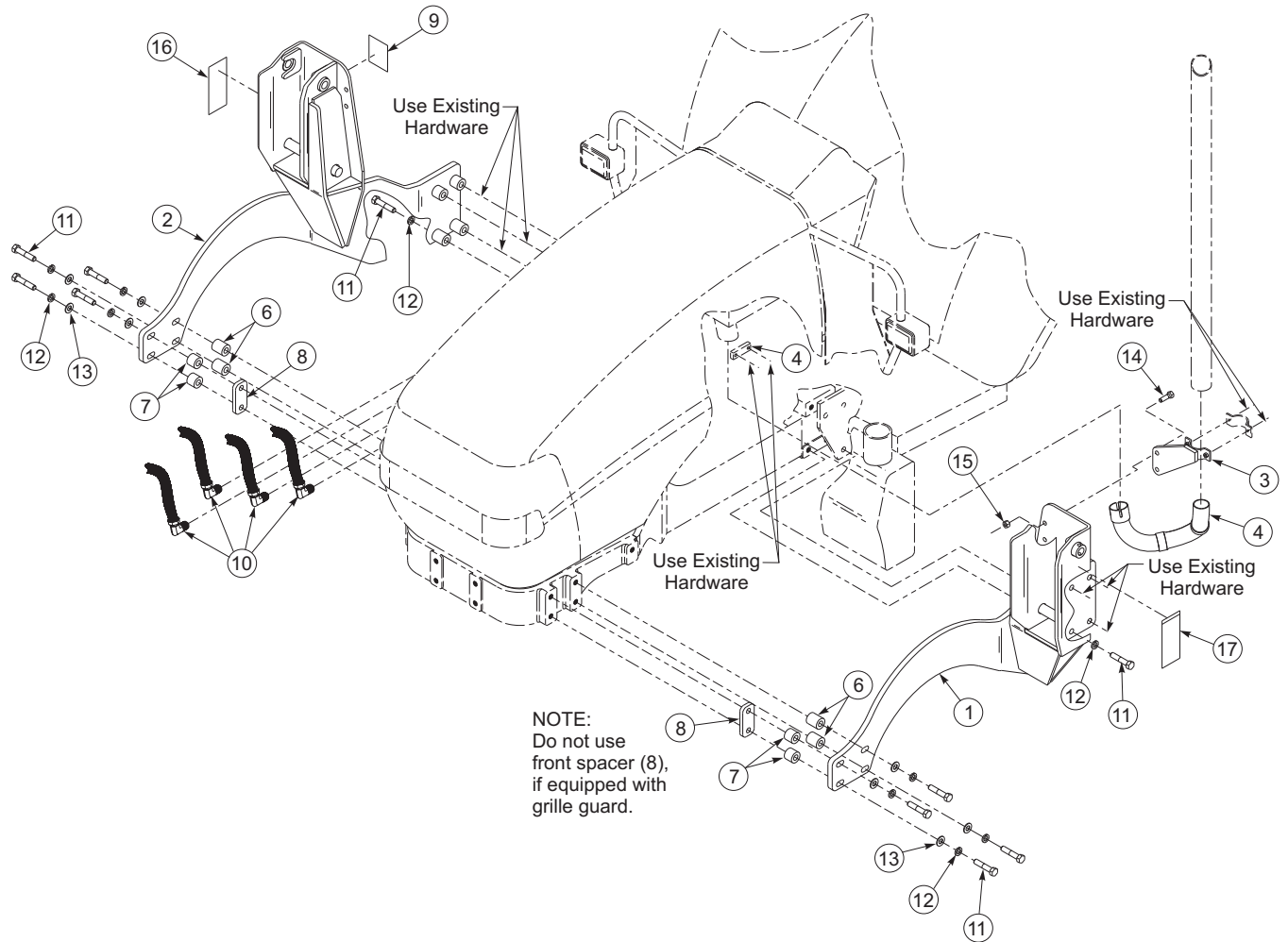

## MOUNTING 4211 LOADER (Figures 2, 3 &amp; 4)



**WARNING:** Loader must be supported before removing hardware securing loader to the shipping pallet, or the loader will tip over.



**WARNING:** To avoid injury during installation of quick attach loader, do not permit bystanders within ten feet of loader.



**WARNING:** To avoid injury during installation of quick attach loader, an overhead hoist must be used for initial mounting. Parking stands are not operational without attachment mounted.

1. Loop chain under each bucket cylinder and hook on loader boom arm (see figure 2A). Using overhead hoist to support loader, remove cotter pins (A), hitch pins (B) and lynch pins (C) (figure 3). Discard only the cotter pins. Then remove hardware securing loader to pallet. Lift loader.

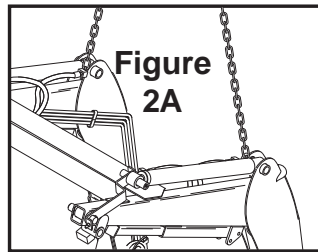
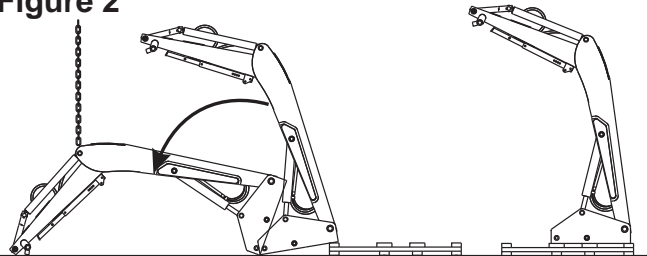

Figure 2



**WARNING:** Loader uprights may rotate downward when loader is lifted from pallet.

2. Position pallet at rear of loader to facilitate lowering (see figure 2). Lower loader from vertical shipping position to horizontal position (scraps of cardboard may be used to protect paint). Remove 3/8" cap screws (D), lock nuts (E), pins (F), shipping brackets (G). Discard shipping brackets, retain hardware for further use. Remove bucket level indicator rod attached to oil lines for shipment.

3. Secure a hoist strap around the boom arm assembly or secure with a chain hook into hole (I), if so provided in underside of boom arm (see figure 3). If using a strap, the strap should be located around the boom arm in about the same location as the chain shown in figure 4. Be sure to keep strap under the oil lines on the right side of the boom.

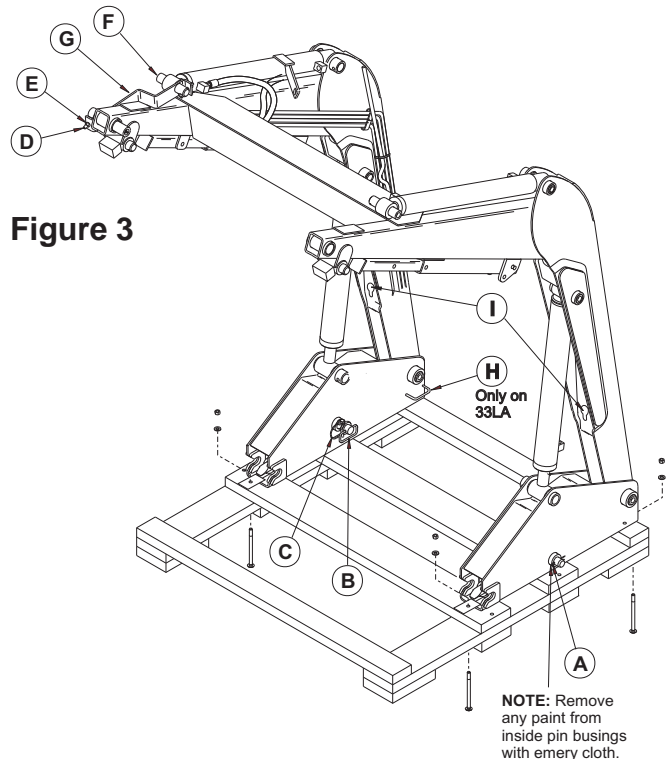
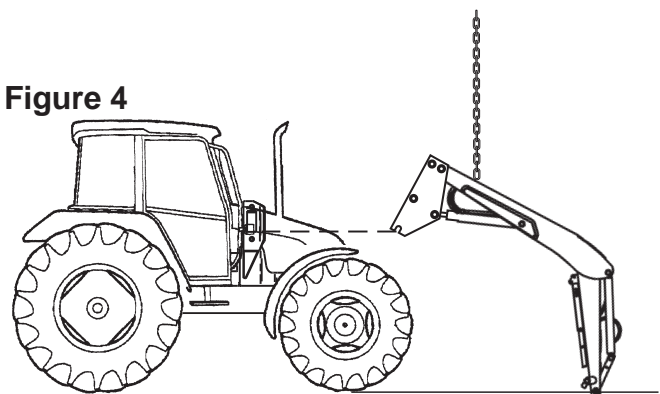

Figure 3

4. Raise loader with overhead hoist as shown in figure 4.

Figure 4



**NOTE:** If the tractor is not equipped with mid-mount couplers, hose kit 2-6859, valve kit 2-7293, or cable controlled valve kit 2-7338 needs to be installed before continuing to mount loader.

(Continued on Page 6)

## MOUNTING 4211-MSL LOADER (Figures 5, 6 & 7)



**WARNING:** Loader must be supported before removing hardware securing loader to the shipping pallet, or the loader will tip over.



**WARNING:** To avoid injury during installation of quick attach loader, do not permit bystanders within ten feet of loader.



**WARNING:** To avoid injury during installation of quick attach loader, an overhead hoist must be used for initial mounting. Parking stands are not operational without attachment mounted.

1. Loop hoist strap or chain around crossmember (see figure 5A). Using overhead hoist to support loader, remove shipping angle braces (B) (figure 6) by removing 1/2" lock nut (A), lift off brace (B), then replace 1/2" lock nut (A).

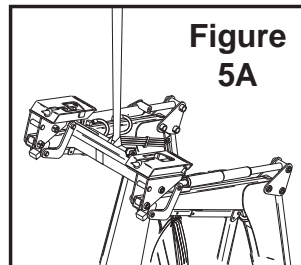

**Figure 5**

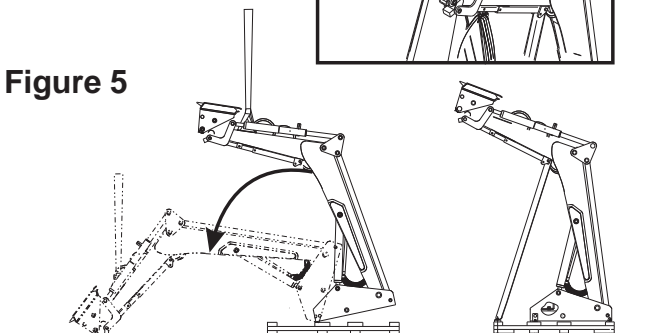

**NOTE:** Discard shipping angle brace.

**NOTE:** Do not over tighten lock nut (A). Parking stand tube must pivot freely.

Remove remaining hardware (C) from shipping braces (B) and discard braces and hardware.

Remove cotter pins (D), hitch pins (F) and lynch pins (E) (figure 6). Discard only the cotter pins. Then remove nuts and washers (C) from bolts securing loader to pallet.

2. Lower loader from vertical shipping position to horizontal position (figure 5) (Loader may require slight push to start lowering). Packaging hardware may bend during lowering process, which is acceptable. Remove bucket level indicator rod attached to oil lines for shipment.

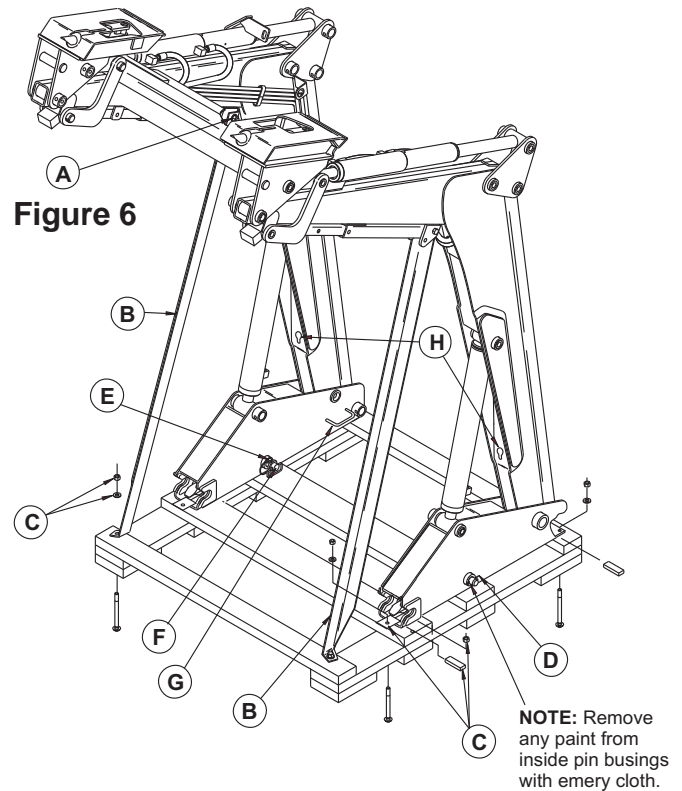

**Figure 6**

3. Secure a hoist chain hook into hole (J) provided in boom underside (refer to figures 6 & 7).
4. Raise loader with overhead hoist as shown in figure 7.

**Figure 7**

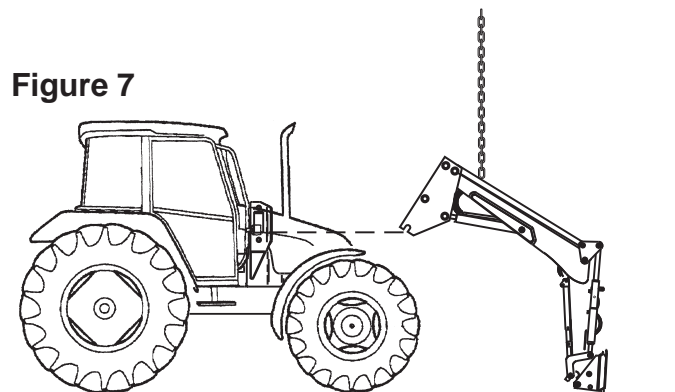

**NOTE:** If the tractor is not equipped with mid-mount couplers, hose kit 2-6859, valve kit 2-7293, or cable controlled valve kit 2-7338 needs to be installed before continuing to mount loader.

(Continued on Page 6)

**MOUNTING 4211-MSL & 4211 LOADERS (Continued)**

**NOTE:** Examine pin bushings and remove any paint with emery cloth before mounting loader (see figures 1, 3 & 6).

**NOTE:** Before continuing mounting procedure, lubricate loader as instructed in loader manual.

5. Remove male couplers from the ends of the hoses supplied on the loader. Install 90° fittings (10) onto hoses and male couplers onto 90° fittings using thread tape on pipe threads to seal. DO NOT overtighten.

A) If the tractor is not equipped with mid-mount couplers, back tractor up to rear of loader. Attach lift cylinder function hoses (color coded green and yellow) to tractor rear remotes. Retract lift cylinders fully and continue to activate control lever for approximately 10 seconds.

B) If tractor is equipped with mid-mount couplers, park tractor next to loader so right side of tractor cab window is parallel with rear of loader upright. Attach colored spiral bands to tractor female couplers to identify hoses. Attach lift cylinder function hoses (color coded green and yellow) to corresponding tractor couplers. Retract lift cylinders fully and continue to activate control lever for approximately 10 seconds.

**NOTE:** Important to attach lift cylinder hoses (yellow and green spiral band coded) for loader to function properly.

Extend lift cylinders about 2" from the fully closed position. Shut off tractor and disconnect hydraulic hoses.

Position tractor directly behind loader. Slowly raise loader with overhead hoist until loader upright will clear tractor front tires.

6. Move tractor forward until loader upright saddles are centered over mounting shaft. Lower loader with overhead hoist until upright saddle straddles mounting shaft.
7. Remove hoist chain or strap from loader boom and secure around front crossmember (Refer to Figure 8). Using overhead hoist raise front of loader to rotate loader upright into mounting pocket. Continue to rotate loader upright until upright has fully rotated into back of mounting guide. Insert two 1" x 7-3/4" pins and lynch pins which were removed from loader uprights in step 1, to secure loader to loader mountings.
8. Connect hoses to tractor hydraulics. Refer to hose kit instructions (2-6859) for tractors using rear remotes.

9. Start engine and slowly cycle cylinders several times to purge air from hydraulic system. Replenish hydraulic system using New Holland 134 hydraulic oil.
10. Adjust front wheel tread settings or steering stops, if necessary to provide a minimum 3/4 inch clearance between front tires and any part of loader with lift cylinders fully retracted and front axle fully oscillated. Be sure lift cylinders are fully retracted. Refer to tractor operator's manual for tread setting and steering stop adjustment procedures.

**Figure 8**

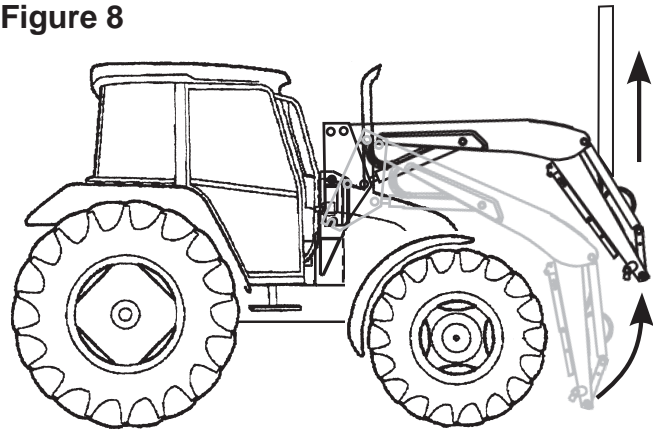
**INSTALLING BUCKET OR ATTACHMENT**

Refer to loader operator's manual to install bucket or optional attachment.

**ATTACH BUCKET LEVEL INDICATOR**

Refer to instruction sheet and assembly manual with bucket or optional attachment.

# GENERAL TORQUE SPECIFICATIONS

USE THE FOLLOWING TORQUES WHEN SPECIAL TORQUES ARE NOT GIVEN

## Standard American and Metric Cap Screws

AMERICAN STANDARD CAP SCREWS									METRIC CAP SCREWS								
SAE Grade	5				8				Metric Class	8.8				10.9			
Typ. Head Markings									Typ. Head Markings								
Cap Screw	TORQUE				TORQUE				Cap Screw	TORQUE				TORQUE			
Size	FT-LBS		N-m		FT-LBS		N-m		Size	FT-LBS		N-m		FT-LBS		N-m	
Inches	MIN	MAX	MIN	MAX	MIN	MAX	MIN	MAX	Millimeters	MIN	MAX	MIN	MAX	MIN	MAX	MIN	MAX
1/4 - 20	6.25	7.25	8.5	10	8.25	9.5	11	13	M6 x 1.00	6	8	8	11	9	11	12	15
1/4 - 28	8	9	11	12	10.5	12	14	16	M8 x 1.25	16	20	21.5	27	23	27	31	36.5
5/16 - 18	14	15	19	20	18.5	20	25	27	M10 x 1.50	29	35	39	47	42	52	57	70
5/16 - 24	17.5	19	23	26	23	25	31	34	M12 x 1.75	52	62	70	84	75	91	102	123
3/8 - 16	26	28	35	38	35	37	47.5	50	M14 x 2.00	85	103	115	139	120	146	163	198
3/8 - 24	31	34	42	46	41	45	55.5	61	M16 x 2.50	130	158	176	214	176	216	238	293
7/16 - 14	41	45	55.5	61	55	60	74.5	81	M18 x 2.50	172	210	233	284	240	294	325	398
7/16 - 20	51	55	69	74.5	68	75	92	102	M20 x 2.50	247	301	335	408	343	426	465	577
1/2 - 13	65	72	88	97.5	86	96	116	130	M22 x 2.50	332	404	450	547	472	576	639	780
1/2 - 20	76	84	103	114	102	112	138	152	M24 x 3.00	423	517	573	700	599	732	812	992
9/16 - 12	95	105	129	142	127	140	172	190	M27 x 3.00	637	779	863	1055	898	1098	1217	1488
9/16 - 18	111	123	150	167	148	164	200	222	M30 x 3.00	872	1066	1181	1444	1224	1496	1658	2027
5/8 - 11	126	139	171	188	168	185	228	251	<p><b>NOTE:</b> These values apply to fasteners as received from supplier, dry or when lubricated with normal engine oil. They do not apply if special graphite or moly sulphide greases or other extreme lubricants are used.</p>								
5/8 - 18	152	168	206	228	203	224	275	304									
3/4 - 10	238	262	322	355	318	350	431	474									
3/4 - 16	274	305	371	409	365	402	495	544									
7/8 - 9	350	386	474	523	466	515	631	698									
7/8 - 14	407	448	551	607	543	597	736	809									
1 - 8	537	592	728	802	716	790	970	1070									
1 - 14	670	740	908	1003	894	987	1211	1337									

### 37° JIC Fittings

Size	Thread Size	Assembly Torque		Tube Connection F. F. F. T.	Swivel Nut or Hose Connection F. F. F. T.
		in.·lb.	ft.·lb.		
-4	7/16 - 20	140 ± 10	12 ± 1	2	2
-5	1/2 - 20	180 ± 15	15 ± 1	2	2
-6	9/16 - 18	250 ± 15	21 ± 1	1 1/2	1 1/4
-8	3/4 - 16	550 ± 25	45 ± 5	1 1/2	1
-12	1 1/16 - 12	1000 ± 50	85 ± 5	1 1/4	1
-16	1 5/16 - 12	1450 ± 50	120 ± 5	1	1
-20	1 5/8 - 12	2000 ± 100	170 ± 10	1	1
-24	1 7/8 - 12	2400 ± 150	200 ± 15	1	1
-32	2 1/2 - 12	3200 ± 200	270 ± 20	1	1

### O-Ring Face Seal Tube/ Hose Swivel Nut

Metric Tube O.D. (mm)	Dash Size	Thread Size (in.)	Swivel Nut Hex Size (in.)	Swivel Nut Torque	
				N-m	lb <sub>f</sub> ·ft
5	-3	--	--	--	--
6	-4	9/16 - 18	11/16	16	12
8	-5	--	--	--	--
10	-6	11/16 - 16	13/16	24	18
12	-8	13/16 - 16	15/16	50	37
16	-10	1 - 14	1-1/8	69	51
20	-12	1-3/16 - 12	1-3/8	102	75
22	-14	1-3/16 - 12	--	102	75
25	-16	1-7/16 - 12	1-5/8	142	105
32	-20	1-11/16 - 12	1-7/8	190	140
38	-24	2 - 12	2-1/4	217	160
50.8	-32	--	--	--	--

### SAE O-Ring Fittings

Size	Swivel Nut or Hose	Assembly Torque		F. F. F. T.
		in.·lb.	ft.·lb.	
2	5/16 - 24	90 ± 5	7.5 ± 0.5	1 ± .25
3	3/8 - 24	170 ± 10	14 ± 1	1 ± .25
4	7/16 - 20	220 ± 15	18 ± 1	1 ± .25
5	1/2 - 20	260 ± 15	22 ± 1	1 ± .25
6	9/16 - 18	320 ± 20	27 ± 2	1.5 ± .25
8	3/4 - 16	570 ± 25	48 ± 2	1.5 ± .25
10	7/8 - 14	1060 ± 50	90 ± 5	1.5 ± .25
12	1 1/16 - 12	1300 ± 50	110 ± 5	1.5 ± .25
14	1 3/16 - 12	1750 ± 75	145 ± 6	1.5 ± .25
16	1 5/16 - 12	1920 ± 125	160 ± 6	1.5 ± .25
20	1 5/8 - 12	2700 ± 150	225 ± 12	1.5 ± .25
24	1 7/8 - 12	3000 ± 150	250 ± 12	1.5 ± .25
32	2 1/2 - 12	3900 ± 200	325 ± 15	1.5 ± .25

# INSTALLATION INSTRUCTIONS