

Keep With Operator's Manual

VALVE AND PLUMBING KIT 2408 LOADER

AGCO ST35, ST35X, ST40, & ST40X FWA TRACTORS WITH SERIAL NUMBER HAVING A "L" OR "M" AND MASSEY FERGUSON 1433, 1433V, 1440 & 1440V FWA TRACTORS

NOTE: AGCO tractors must have "L" or "M" in serial number. 2-7301 Mount Kit must be used.

TRACTOR AND VALVE KIT GENERAL INFORMATION

This kit includes a joystick and parallel valve which can perform two functions simultaneously, each at full valve pressure. However, the function requiring lower pressure will take priority.

Example: When simultaneously operating lift and roll-back, bucket may roll back until tilt cylinders are completely retracted before lift cylinders raise loader.

Each function can be operated separately when desired.

Valve and plumbing kit can be installed on tractor using tools ordinarily available. Valve control handle has been factory preassembled for ease of installation. Shut off the tractor engine, engage tractor brakes and completely lower three point hitch during installation.

NOTE: Apply sealant only to all tapered threads unless coupled with swivel adapters. When using Teflon tape, wrap tape clockwise (as viewed from end) and wrap only twice. Keep sealant away from first two threads of tapered end to prevent contamination of hydraulic fluid. Do not use sealant on O-ring or flare adapter threads.



WARNING: Escaping hydraulic fluid under pressure can penetrate skin causing serious injury.

- DO NOT use your hands to check for leaks. Use a piece of cardboard or paper to search for leaks.
- Stop engine and relieve pressure before connecting or disconnecting lines.
- Tighten all connections before starting engine or pressurizing lines.

If any fluid is injected into skin, obtain medical attention immediately or gangrene may result.

ATTACHING VALVE TO LOADER MOUNTING BRACKET (Figures 1, 2, & 3)

1. Attach valve mounting tube (24) to loader right mid mounting bracket using 1/2 x 2-1/4" cap screws (11), flat washers (31) and lock nuts (30).
2. Install 3/4 x 9/16 elbow fitting (9) into power beyond port of valve (1). Install adapter fittings (22), female quick couplers (15) and 1" colored bands (16) to working ports of valve (1).
3. Fasten valve mounting plate (23) to valve mounting tube (24) using 3/8 x 2-1/4" cap screws (2) and lock nuts (5). Insert end cap plug (33) into top end of mounting tube (24).
4. Fasten valve (1) with elbow (9) in power beyond port toward bottom, to valve mounting plate (23) using 5/16 x 3/4" cap screws (6) and lock washers (7).
5. Fasten decal mounting plate (4) to valve using 5/16 x 3/4" cap screw (6) and lock washer (7). Making sure surface of decal mounting plate (4) is clean and dry, remove backing from operation decal (20) and apply it to decal mounting plate (4).
6. Thread nut (13) onto handle (3). Attach handle (3) to valve (1). Slip boot (14) over handle and cover handle assembly. Attach ball (8) to handle (3).

Fasten valve to plate using holes in these locations.

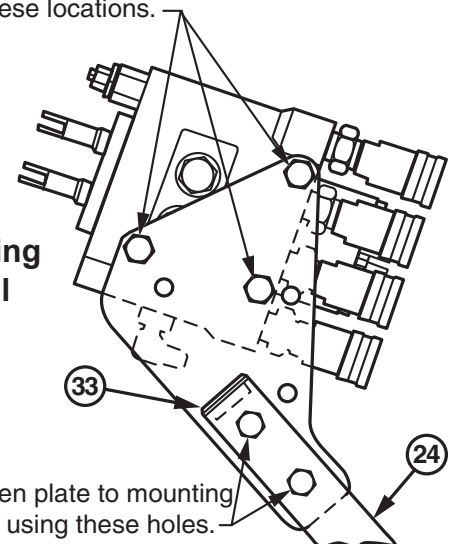

**Figure 1
Valve Mounting
Plate Detail**

Fasten plate to mounting tube using these holes.

2-7302

PLUMBING CONTROL VALVE TO TRACTOR HYDRAULICS (Figures 2, 3 & 4)

1. Remove hydraulic plugs from tractor ports on right side below platform. Install diverter plug (34) into center port. Install 3/8 straight adapter fittings (28) into remaining two holes. Install 90° elbow fittings (29) onto adapter fittings (28).
2. Remove return plug from right side of tractor located behind tractor hydraulic ports. Fasten 90° elbow adapter fitting (27) into return port.
3. Slide 60" sleeve (36) over return hose (10). Slide one 56" sleeve (35) over power beyond hose (12). Slide other 56" sleeve (35) over pressure hose (32).
4. Connect pressure, return, and power beyond hoses (32, 10 & 12) to pressure, return, and power beyond ports of valve.
5. Route hoses down valve mounting tube (24), under platform and back to hydraulic ports.
6. Connect pressure hose (32) to pressure port fitting (29) on tractor. Connect power beyond hose (12) to power beyond port fitting (29). Connect return hose (10) to return port fitting (27) on tractor.
7. Secure hoses to valve mounting tube (24) and tractor frame using plastic tie straps (21).

**Figure 2
Identifying
Valve Ports**

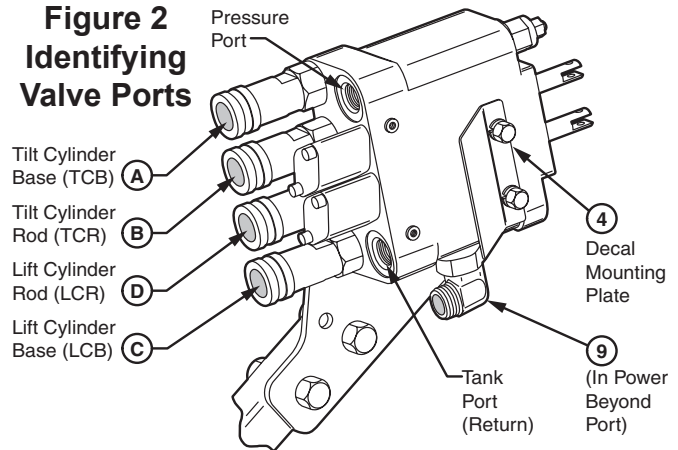

PLUMBING LOADER TO CONTROL VALVE

1. Install 3/8 x 72" hoses (17) onto boom oil line tubes. Install and tighten hose fittings one at a time from bottom up. Loosening closest oil line clamp will ease installation.
2. Install spiral bands (18) onto free ends of hoses (17) to match bands on female quick couplers (15). Slide nylon sleeves (25) over hoses (17) and install male quick couplers (19) onto free ends of hoses.
3. Connect hoses from upper two boom oil lines to upper quick couplers and connect hoses from lower two boom oil lines to lower quick couplers. Wrap rubber strap (26) around nylon sleeves (25) over hoses (17) and hook onto itself. Attach free end of rubber strap to hole provided in right side frame channel.
4. After all plumbing has been completed, slowly cycle lift and bucket cylinders several times to purge air from hydraulic system. Retract cylinders and shut off tractor engine. Replenish tractor hydraulic system.

NOTE: When cycling loader, operate loader according to operation decal (20) on valve box. If direction of control lever is wrong, or loader will not lower, recheck connections shown.



WARNING: Escaping hydraulic fluid under pressure can have sufficient force to penetrate skin causing serious personal injury. If injured by escaping hydraulic fluid, obtain medical treatment immediately.

PRINCE LVR VALVE SERVICE

Following is an outline procedure for disassembling and reassembling valve.



WARNING: The valve has a factory pre-set valve relief setting. Tampering with this setting can cause serious injury to operator and damage to tractor or loader. Unauthorized adjustments or service to valve relief will VOID WARRANTY of both loader and tractor. If adjustments or service to valve relief are required during warranty period, an authorized service department must be consulted for authorization.

VALVE DISASSEMBLY (Figure 4)

NOTE: Mark or tag all parts so they are reinstalled in their proper positions.

1. Slide boot (6) to top of handle (34). Remove hex head cap screws (36) from rod ends (9 & 10). Remove handle with boot and adapter plate (8). Remove nuts (28 & 31) from spool stud (7) and rod end assemblies (10). Remove spool stud (7) and rod end assemblies (10) from valve.

NOTE: Spool adapters (33) are factory assembled. Removal from spools is not necessary. If replacing a damaged adapter, clean threads with loctite primer and install using loctite 262.

2. Remove hex head cap screws (13) and end caps (14) from both spools. Remove detent sleeve (12) from regen spool. Remove steel balls (20), poppet (21), and poppet spring (19) from detent retainer (24). Remove retaining flat (15) and detent spacer (16) from regen spool.
3. Secure handle end of regen spool. Using a rod through retainer ball holes, remove detent retainer (24) from regen spool.

NOTE: Detent retainers (18 & 24) are installed on spools using Loctite 222 or equivalent. If spool adapter comes loose instead of detent retainer, pull spool completely out of valve and secure spool using vice grips on land section of spool not machined for valve bore.

4. Remove washer (17), centering spring (26), and stop cup (23) from regen spool.
5. Holding in on float detent sleeve (22), push in float spool from handle end and remove steel balls (20) from float detent retainer (18). Remove float detent sleeve (22), poppet (21), poppet spring (19), retaining flat (15) and spacer (16) from float spool.

6. Secure handle end of float spool. Using a rod through retainer ball holes, remove detent retainer (18) from float spool.

NOTE: Detent retainers (18 & 24) are installed on spools using Loctite 222 or equivalent. If spool adapter comes loose instead of detent retainer, pull spool completely out of valve and secure spool using vice grips on land section of spool not machined for valve bore.

Remove washer (17), centering spring (26) and stop cup (23) from float spool.

7. Push spools in from handle end until rear spool seals (1) are exposed. Using wire hook and screwdriver remove rear spool seals. Push spools in from the rear until front spool seals (1) are exposed. Using wire hook and screwdriver remove front spool seals.
8. Clean all parts, including valve body, in suitable cleaning solvent. After cleaning parts with solvent, use air pressure to blow any dirt or excess solvent from all parts including inside of valve body.

VALVE REASSEMBLY

1. Examine all parts for wear and damage and replace if necessary.
2. Lubricate all O-rings and spools with oil to prevent damage when assembling.
3. Lubricate all detent and spring centering parts with a light coat of grease before assembling.
4. Reassemble all parts in reverse order of disassembly.

NOTE: Use Loctite 222 or equivalent when installing detent retainers (18 & 24).

RELIEF VALVE, LOAD CHECK PLUGS and POWER BEYOND SLEEVE

NOTE: Relief valve (3), load check plugs (27) and power beyond sleeve (2) may be removed separately to clean inspect or replace parts without removing valve spools.

NOTE: If repairing or replacing relief valve (3), torque larger hex nut (relief body) to 20-25 ft-lbs.

REPLACING HANDLE PARTS

If replacing damaged handle parts, clean threads with loctite primer and install using loctite 242. Torque parts as shown in Figure 4.

2-7302

PARTS LIST – VALVE & PLUMBING KIT

Item	Part No.	Description	Qty.
1	53464	VALVE, Prince LVR (2500 PSI)	1
2	41838-19	SCREW, Cap, 3/8-16 x 2-1/4	2
3	43517	HANDLE, Standard	1
4	43451	ANGLE, Decal Mounting	1
5	41840-3	NUT, Lock, 3/8-16	2
6	41838-26	SCREW, Cap, 5/16-18 x 3/4"	4
7	41837-2	WASHER, Lock, 5/16"	4
8	38902	BALL, Valve Handle	1
9	32845-7	FITTING, Elbow, 9/16-18 JIC x 3/4-15 O-ring, 90°	1
10	43454-3	HOSE, 3/8 x 60" Return (Tank)	1
11	41838-18	SCREW, Cap, 1/2-13 x 2-1/4"	2
12	36386-23	HOSE, 3/8 x 54" Power Beyond	1
13	G271506	NUT, Hex, 7/16-20	1
14	43635	BOOT, Valve Handle	1
15	6147-4	COUPLER, Quick, Female, 3/8"	4
16	36240-9	BAND, Spiral Plastic, 1" Blue	1
	36240-10	BAND, Spiral Plastic, 1" Red	1
	36240-11	BAND, Spiral Plastic, 1" Yellow	1
	36240-12	BAND, Spiral Plastic, 1" Green	1
17	36336-3	HOSE, 3/8 x 72"	4
18	36240-5	BAND, Spiral Plastic, 5/8" Blue	1
	36240-6	BAND, Spiral Plastic, 5/8" Red	1
	36240-7	BAND, Spiral Plastic, 5/8" Yellow	1
	36240-8	BAND, Spiral, Plastic, 5/8" Green	1
19	6137-4	COUPLER, Quick, Male, 3/8"	4
20	43453	DECAL, Single Handle Control	1
21	8137-1	STRAP, Adjustable	3
22	39280-7	FITTING, Adapter, 3/4-16 O-ring x 3/8 NPT	4
23	43450	PLATE, Valve Mounting	1
24	51643	TUBE, Valve Mounting	1
25	34853-18	SLEEVE, Hose 66" (Loader Hoses)	4
26	7438-1	STRAP, Tarp	1
27	39609-7	FITTING, Elbow, 90°, 1/2-14 NPTF x 9/16-18 JIC	1
28	43518-1	FITTING, Straight, 3/8-19 BSPT x 9/16-18 JIC	2
29	34128-3	FITTING, Elbow, 90°, 9/16-18 JIC x 9/16-18 JIC	2
30	41840-5	NUT, Lock, 1/2-13	2
31	42502-10	WASHER, Flat, 1/2	2
32	43454-15	HOSE, 3/8 x 56" Pressure	1
33	44274-1	END CAP, Plug	1
34	51056	DIVERTER Plug, with O-rings (Massey Ferguson Part number 71515036)	1
35	34853-35	SLEEVE, Hose 56" (Power Beyond Hose & Pressure Hose)	2
36	34853-37	SLEEVE, Hose 60" (Return Hose)	1

Figure 3

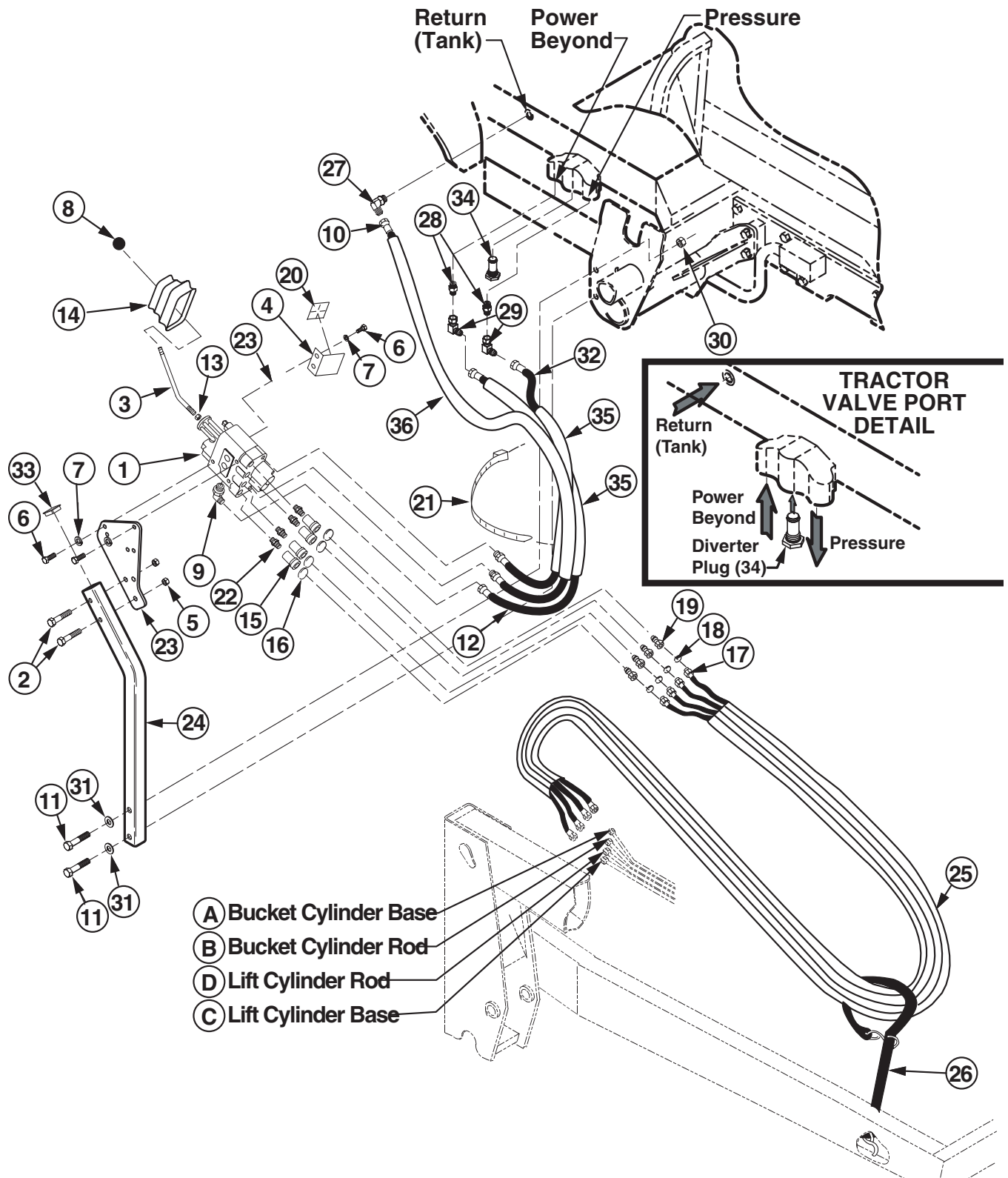

2-7302**PARTS LIST – PRINCE LVR VALVE**

Item	Part No.	Description	Qty.
1	43633	SEAL KIT	1
2	43636	POWER BEYOND SLEEVE	1
3	43637-2	RELIEF VALVE (2500 PSI)	1
4	43638	FLOAT KIT, (Includes 13, 14, 15, 16, 17, 18, 19, 20, 21, 22, 23, and 26)	1
5	43639	REGEN KIT, (Includes items 12, 13, 14, 15, 16, 17, 19, 20, 21, 24, and 26)	1
6	43635	BOOT, Rubber, Valve Handle	1
7	51076	STUD, Spool	1
8	51078	ADAPTER PLATE	1
9	38900-4	ROD END	1
10	51075	ROD END, Assembly	2
11	51079	CLEVIS	1
14	44476-2	END CAP (Manufacturer's part number (HC-V-AA26) stamped on end cap identifies valve and relief setting)	2
25	44743-5	SCREW, Cap, Socket Head, 1/4-20 x 1/2"	2
26	44460	PLUG, Load Check	2
28	41836-2	NUT, Hex, 5/16"	3
29	44743-3	SCREW, Cap, Socket Head, 1/4-20 x 7/8"	2
30	51080	PLATE	1
31	51081	WASHER, Shim, 5/16"	1
32	G271506	NUT, Hex, 7/16-20	1
33	51077	END, Spool	2
34	43517	HANDLE, Valve, Standard	1
35	38902	BALL, Handle	1
36	44743-4	SCREW, Cap, Socket Head, 5/16-24 x 3/4"	3
37	G120383	WASHER, Lock, 7/16"	1

NOTE: Individual items not listed in repair parts listing are not available separately.

Figure 4

Spool ends do not need to be removed to service valve. If replacing damaged spool end, clean threads using Loctite® primer and install using Loctite® 262.

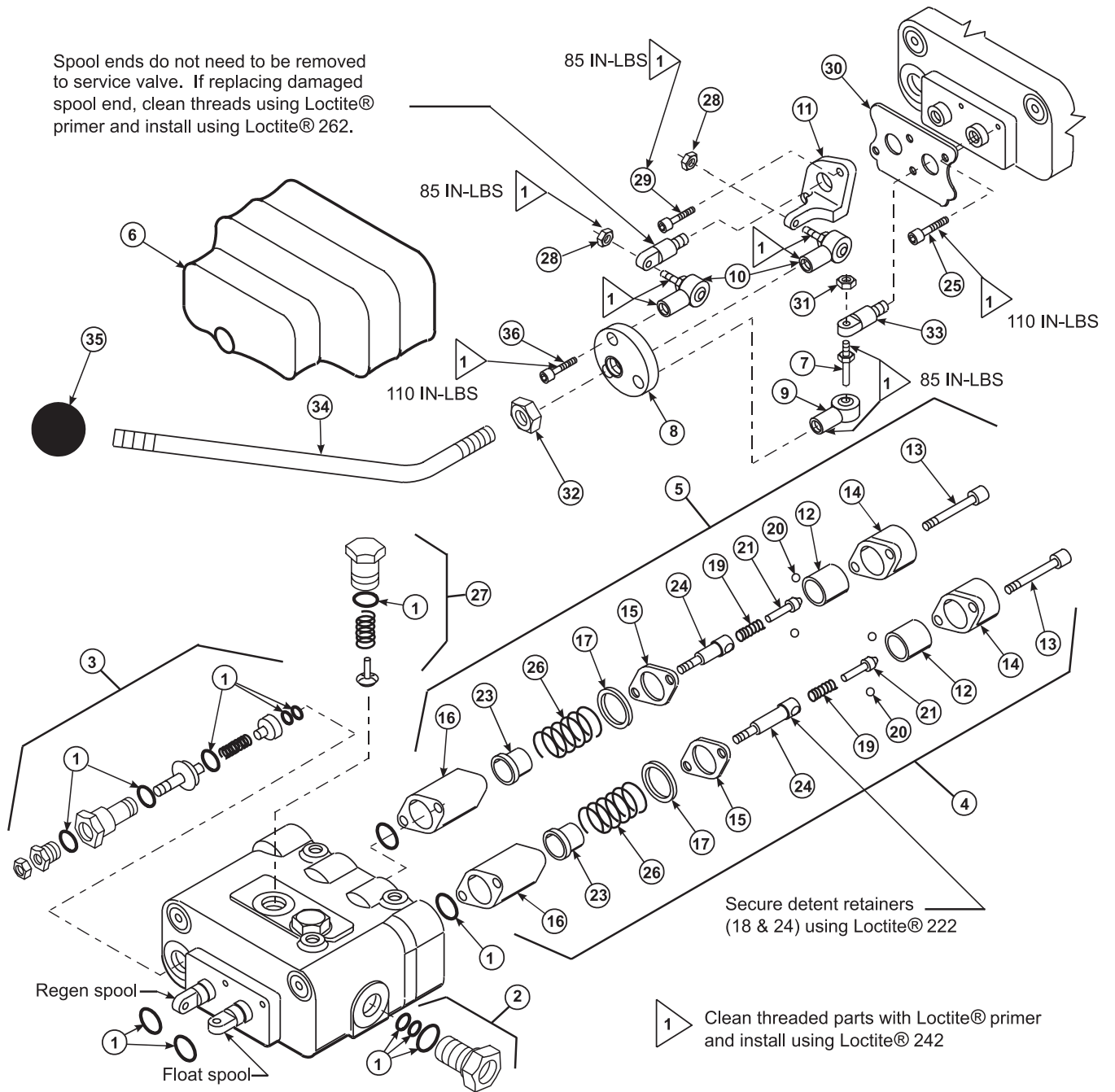
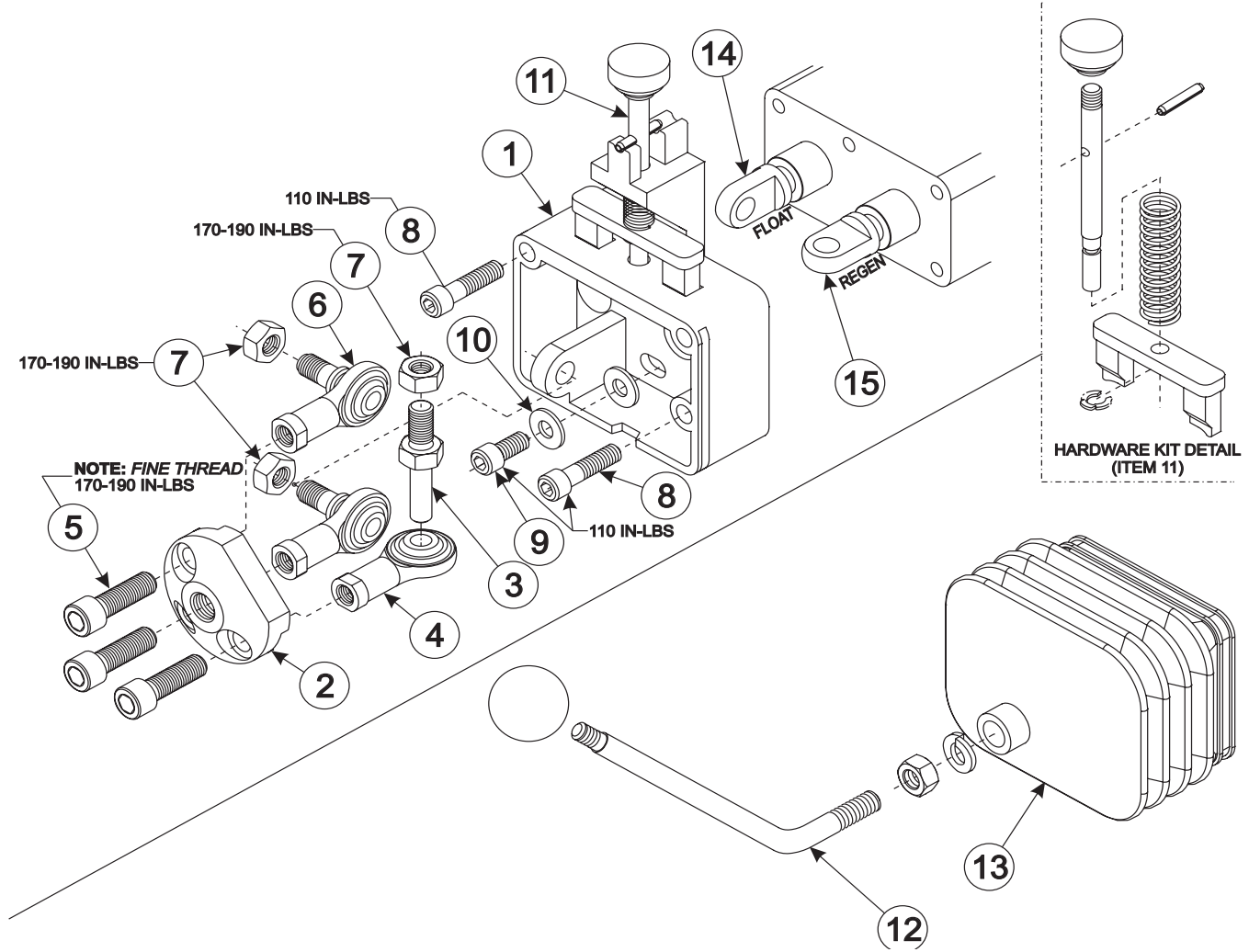

Figure 5
VALVE EQUIPPED WITH LOCKOUT FEATURE



PARTS LIST - JOYSTICK SUB-ASSY WITH DUAL SPOOL LOCK

Item	Part No.	Description	Qty.
1	*	CLEVIS, Spool Lock	1
2	*	PLATE, Adapter	1
3	55821	STUD, Spool	1
4	55822	END, Rod	1
5	*	SCREW, Cap	3
6	55823	ASSY, Rod End	2
7	*	NUT, Hex	3
8	*	SCREW, Cap	2
9	*	SCREW, Cap	1
10	*	WASHER, Flat	1
11	55824	KIT, Spool Lock Hardware	1
12	56004	KIT, Bent Handle	1
13	55826	KIT, Boot/Cable Tie	1
14	55917	ADAPTER, Float Spool	1
15	55918	ADAPTER, Regen Spool	1
16	55827	KIT, Sub-Assy, Includes Items 1-11	1

* **NOTE:** Individual items not listed in repair parts listing are not available separately.
For valve block service parts, see previous page.

GENERAL TORQUE SPECIFICATIONS

USE THE FOLLOWING TORQUES WHEN SPECIAL TORQUES ARE NOT GIVEN

Standard American and Metric Cap Screws

AMERICAN STANDARD CAP SCREWS									METRIC CAP SCREWS								
SAE Grade	5				8				Metric Class	8.8				10.9			
Typ. Head Markings									Typ. Head Markings								
Cap Screw	TORQUE				TORQUE				Cap Screw	TORQUE				TORQUE			
Size	FT·LBS		N·m		FT·LBS		N·m		Size	FT·LBS		N·m		FT·LBS		N·m	
Inches	MIN	MAX	MIN	MAX	MIN	MAX	MIN	MAX	Millimeters	MIN	MAX	MIN	MAX	MIN	MAX	MIN	MAX
1/4 - 20	6.25	7.25	8.5	10	8.25	9.5	11	13	M6 x 1.00	6	8	8.25	11	9	11	12	15
1/4 - 28	8	9	11	12	10.5	12	14	16	M8 x 1.25	16	20	21.5	27	23	27	31	36.5
5/16 - 18	14	15	19	20	18.5	20	25	27	M10 x 1.50	29	35	39	47	42	52	57	70
5/16 - 24	17.5	19	23	26	23	25	31	34	M12 x 1.75	52	62	70	84	75	91	102	123
3/8 - 16	26	28	35	38	35	37	47.5	50	M14 x 2.00	85	103	115	139	120	146	163	198
3/8 - 24	31	34	42	46	41	45	55.5	61	M16 x 2.50	130	158	176	214	176	216	238	293
7/16 - 14	41	45	55.5	61	55	60	74.5	81	M18 x 2.50	172	210	233	284	240	294	325	398
7/16 - 20	51	55	69	74.5	68	75	92	102	M20 x 2.50	247	301	335	408	343	426	465	577
1/2 - 13	65	72	88	97.5	86	96	116	130	M22 x 2.50	332	404	450	547	472	576	639	780
1/2 - 20	76	84	103	114	102	112	138	152	M24 x 3.00	423	517	573	700	599	732	812	992
9/16 - 12	95	105	129	142	127	140	172	190	M27 x 3.00	637	779	863	1055	898	1098	1217	1488
9/16 - 18	111	123	150	167	148	164	200	222	M30 x 3.00	872	1066	1181	1444	1224	1496	1658	2027
5/8 - 11	126	139	171	188	168	185	228	251	<p>NOTE: These values apply to fasteners as received from supplier, dry or when lubricated with normal engine oil. They do not apply if special graphite or moly sulphide greases or other extreme lubricants are used.</p>								
5/8 - 18	152	168	206	228	203	224	275	304									
3/4 - 10	238	262	322	355	318	350	431	474									
3/4 - 16	274	305	371	409	365	402	495	544									
7/8 - 9	350	386	474	523	466	515	631	698									
7/8 - 14	407	448	551	607	543	597	736	809									
1 - 8	537	592	728	802	716	790	970	1070									
1 - 14	670	740	908	1003	894	987	1211	1337									

37° JIC Fittings

Size	Thread Size	Assembly Torque		Tube Connection F. F. F. T.	Swivel Nut or Hose Connection F. F. F. T.
		in.·lb.	ft.·lb.		
-4	7/16 - 20	140 ± 10	12 ± 1	2	2
-5	1/2 - 20	180 ± 15	15 ± 1	2	2
-6	9/16 - 18	250 ± 15	21 ± 1	1 1/2	1 1/4
-8	3/4 - 16	550 ± 25	45 ± 5	1 1/2	1
-12	1 1/16 - 12	1000 ± 50	85 ± 5	1 1/4	1
-16	1 5/16 - 12	1450 ± 50	120 ± 5	1	1
-20	1 5/8 - 12	2000 ± 100	170 ± 10	1	1
-24	1 7/8 - 12	2400 ± 150	200 ± 15	1	1
-32	2 1/2 - 12	3200 ± 200	270 ± 20	1	1

O-Ring Face Seal Tube/ Hose Swivel Nut

Metric Tube O.D. (mm)	Dash Size	Thread Size (in.)	Swivel Nut Hex Size (in.)	Swivel Nut Torque	
				N·m	lb _f ·ft
5	-3	--	--	--	--
6	-4	9/16 - 18	11/16	16	12
8	-5	--	--	--	--
10	-6	11/16 - 16	13/16	24	18
12	-8	13/16 - 16	15/16	50	37
16	-10	1 - 14	1-1/8	69	51
20	-12	1-3/16 - 12	1-3/8	102	75
22	-14	1-3/16 - 12	--	102	75
25	-16	1-7/16 - 12	1-5/8	142	105
32	-20	1-11/16 - 12	1-7/8	190	140
38	-24	2 - 12	2-1/4	217	160
50.8	-32	--	--	--	--

SAE O-Ring Fittings

Size	Swivel Nut or Hose	Assembly Torque		F. F. F. T.
		in.·lb.	ft.·lb.	
2	5/16 - 24	90 ± 5	7.5 ± 0.5	1 ± .25
3	3/8 - 24	170 ± 10	14 ± 1	1 ± .25
4	7/16 - 20	220 ± 15	18 ± 1	1 ± .25
5	1/2 - 20	260 ± 15	22 ± 1	1 ± .25
6	9/16 - 18	320 ± 20	27 ± 2	1.5 ± .25
8	3/4 - 16	570 ± 25	48 ± 2	1.5 ± .25
10	7/8 - 14	1060 ± 50	90 ± 5	1.5 ± .25
12	1 1/16 - 12	1300 ± 50	110 ± 5	1.5 ± .25
14	1 3/16 - 12	1750 ± 75	145 ± 6	1.5 ± .25
16	1 5/16 - 12	1920 ± 125	160 ± 6	1.5 ± .25
20	1 5/8 - 12	2700 ± 150	225 ± 12	1.5 ± .25
24	1 7/8 - 12	3000 ± 150	250 ± 12	1.5 ± .25
32	2 1/2 - 12	3900 ± 200	325 ± 15	1.5 ± .25

INSTALLATION INSTRUCTIONS