

Keep With Operator's Manual

MOUNTING KIT 2405 LOADER KUBOTA BX1500 TRACTORS

Mounting brackets can be installed on the tractor using tools ordinarily available. Shut off tractor engine and engage tractor brakes during installation.

NOTE: Leave all attaching hardware loose until mounting brackets are completely assembled to facilitate assembly and proper alignment.

INSTALLING MOUNTING BRACKETS (Figure 1)

1. Fasten front mounting bracket (1) to tractor frame using four 1/2-13 x 1-1/2 cap screws (5) with 1/2 lock nuts (6).
2. Install midmounting brackets (2 & 3) to tractor frame using twelve 9/16-18 x 1-1/2 cap screws (7), 9/16 lock washers (8) and 9/16-18 lock nuts (9) as illustrated in figure 1.

INSTALLING LOADER TO MOUNTING BRACKETS



WARNING: To avoid injury during installation of quick attach loader, do not permit bystanders within ten feet of loader.

1. Using overhead hoist to support loader remove hardware securing loader to pallet. Lift loader and remove pallet.



CAUTION: Do not damage grease fitting on end of cylinder. Be sure chain does not pinch lift cylinder hose.

2. Using overhead hoist, lower loader from vertical shipping position to horizontal position leaving enough room to install yoke (scraps of cardboard may be used to protect paint). Install yoke assembly (4) using 1/2-13 x 1-1/2 cap screws (5) and 1/2-13 lock nuts (6). Lower loader completely to the ground.

NOTE: Hardware connecting yoke to loader side-frames should be snug but do not torque completely. After loader has been mounted to tractor and aligned with midmounting brackets and front mounting brackets, torque hardware to specifications in loader operators manual.

3. Install valve kit to tractor and loader. Refer to assembly manual provided for installation instructions.
4. Position tractor close enough so plumbing can be connected to tractor. Route hoses loosely to allow maximum reach. Using nylon straps reposition overhead hoist to loader boom arms near pivot point to side frames.
5. Remove 1/2 x 1-3/4 cap screws, washers and lock nuts so hinges can be opened. They should stay open by themselves. If not, tighten carriage bolt until slight resistance is felt. Do not overtighten. To ease mounting and dismounting of loader, grease carriage bolt head. Lower loader to a horizontal position and attach nylon slings around the loader lift boom arms.
6. Use overhead hoist to raise the loader and position the side frames over the front mounting bracket. Slide the loader to the rear until side frame uprights are on the mid mounting tubes.
7. Clamp hinges around tubes of mid mounting. Fasten with 1/2 x 1-3/4 cap screws, flat washers, lock washers and nuts (supplied with loader).
8. Refer to loader owner's manual and plumbing kit instructions to complete loader installation and for location of decals.

Figure 1
Mount Kit Assembly

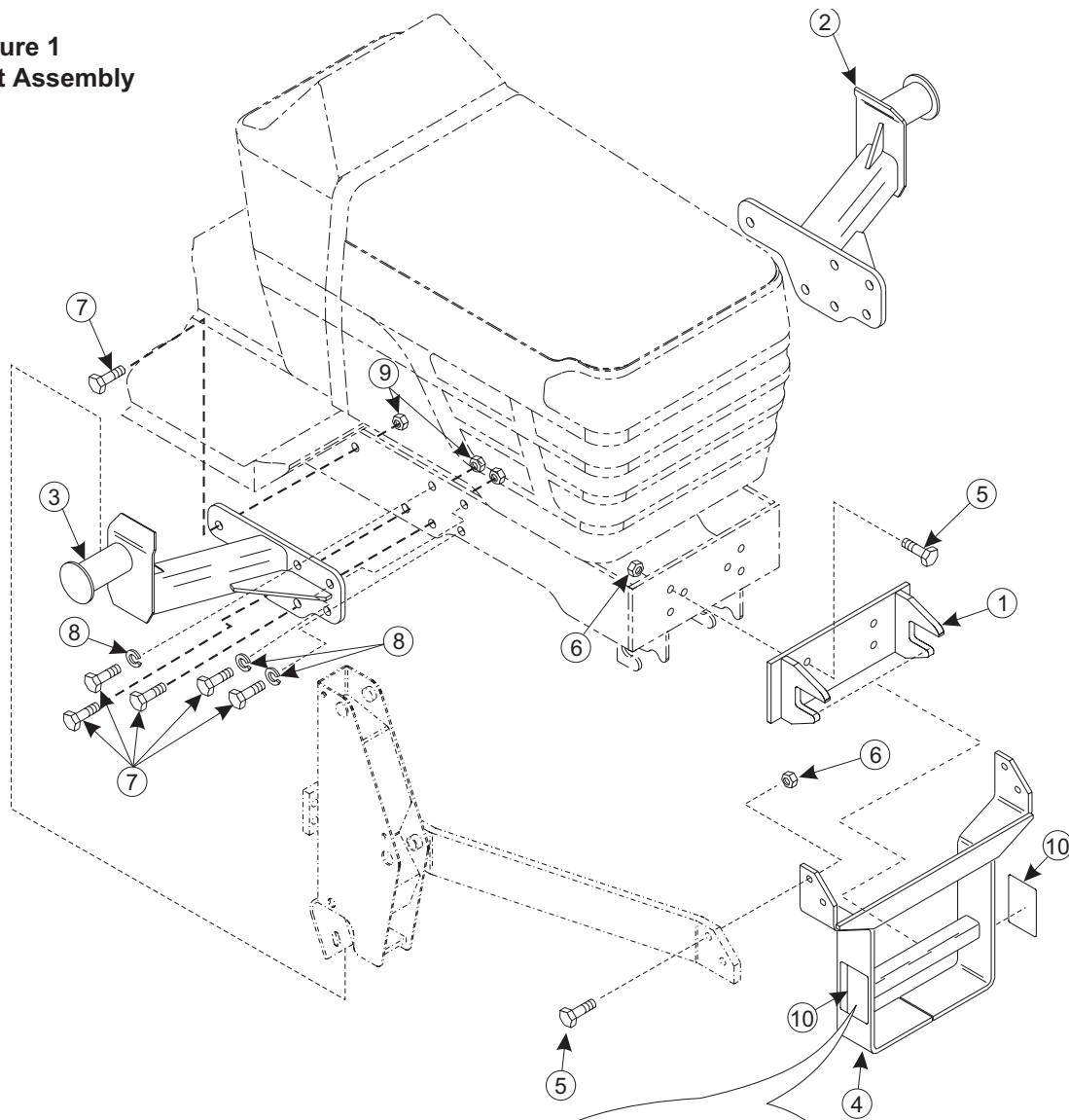

PARTS LIST - MOUNTING KIT

ITEM	PART NO.	DESCRIPTION	QTY.
1	51601	FRONT MOUNTING BRACKET	1
2	51595-1	MIDMOUNTING BRACKET, Left	1
3	51595-2	MIDMOUNTING BRACKET, Right	1
4	49197	YOKE ASSEMBLY, with Decals	1
5	41838-33	SCREW, Cap, 1/2 -13 x 1-1/2	8
6	41840-5	NUT, Lock, 1/2 -13	8
7	41838-72	SCREW, Cap, 9/16-18 x 1-1/2	12
8	41837-6	WASHER, Lock, 9/16	6
9	41840-26	NUT, Lock, 9/16-18	6
10	39240	DECAL, Warning	2