

Keep With Operator's Manual

**VALVE & PLUMBING KIT (PARALLEL)
4211 AND 4211 MSL LOADER
CASE IH TRACTORS**

MODEL	2WD	4WD	ROPS	CAB
JX55, JX65	x	x	x	x
JX75, JX85	x	x	x	x

Valve and plumbing kit can be installed using tools ordinarily available. Valve control handle has been factory pre-assembled for ease of installation. Shut off engine and engage brakes during installation.

NOTE: Apply sealant only to all tapered threads unless coupled with swivel adapters. When using Teflon tape, wrap tape clockwise (as viewed from end) and wrap tape only twice. Keep sealant away from first two threads of tapered end to prevent contamination of hydraulic fluid. Do not use sealant on O-ring of flare adapter threads.



WARNING: Escaping hydraulic fluid under pressure can penetrate skin causing serious injury.

- DO NOT use your hand to check for leaks. Use a piece of cardboard or paper to search for leaks.
- Stop engine and relieve pressure before connecting or disconnecting lines.
- Tighten all connections before starting engine or pressurizing lines.

If any fluid is injected into skin, obtain medical treatment immediately or gangrene may result.

CABLE HARNESS ASSEMBLY (Figures 2 & 3)

1. Loosely fasten cables (16) to cable straps (20) using 3/4" jam nuts (17), 3/4" internal tooth lock washer (18), and 3/4" knurled nut (19). Attach spool clevis (24) to cable ends (16) using 5/16" jam nuts (21); one on each side. Remove protective caps on opposite end of cable (16) and attach cable adapter (15). (Figure 2).
2. Fasten cable assemblies (26) to valve using 1/4"-20 x 3/8" socket head cap screws (25). Note which cable is "lift" and which is "tilt". Attach spool clevis (24) to lift and tilt spool of valve using 5/16" x 1" clevis pins (23) and cotter pins (22). (Figure 2).

Figure 1

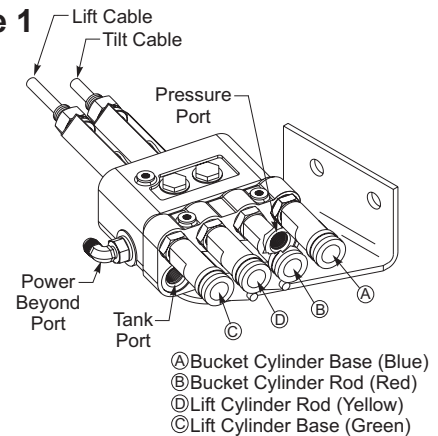

ATTACHING VALVE TO TRACTOR (Figure 4)

1. On right side, remove bottom two 16MM bolts securing cab/platform support plate and loader mount. Fasten valve mount plate (4) and 1/2" spacer (20) to tractor using 16MM x 120MM bolts (13) and 5/8" lock washers (14).
2. Install 90° fitting (9) to power beyond port of valve (1). Install adapter fitting, female couplers (15), and 1" colored spiral rings (16) to working ports of valve.
3. Attach valve (1) to mount plate (4) using 5/16" x 3/4" cap screws (6) and 5/16" lock washers (7).
4. Attach 60" tank and pressure hoses (10) to respective ports on valve (1). Slide 60" sleeves (18) over each hose (18). (Figure 1)
5. Loop pressure and tank hoses (10) and route along cab/platform support plate. Thread all three hoses (10 & 12) through factory installed steel hanger loop.
6. Attach cover plate (11) to top of valve (1) using 5/16" x 3/4" cap screws (6) and 5/16" lock washers (7).
7. Near right rear axle, remove the steel hydraulic tube. Attach 30" power beyond hose (12) to top port. Attach pressure hose (10) to bottom port. Remove tank plug located approximately between the power beyond and pressure ports. Fasten tank hose (10) to tank port.

PARTS LIST - JOYSTICK AND CABLE HARNESS

ITEM	PART NO.	DESCRIPTION	QTY.
1	51814	HANDLE, Plastic	1
2	G11506909	SCREW, Set, 6MM-1.00 x 8MM LG	1
3	51805	BOOT	1
4	*	HANDLE ASSEMBLY, Joystick	1
5	*	RETAINING RING, External 15/16"	4
6	*	ROD END, Single	1
7	*	ROD END, Double	1
8	51894	BOLT, Pan Head Slotted, 6MM-1.00 x 22MM LG	1
9	*	CLEVIS	1
10	**	NUT, Lock, Nylon Insert, 6MM-1.00	1
11	54740	BASE W/LOCK MECHANISM	1
12	41837-1	WASHER, Lock, 1/4"	1
13	51812-1	SCREW, Socket Head, 6MM-1.00 x 30MM	1
14		CABLE TIE, 3/16" (not available as service part)	1
15	52242	CABLE ADAPTER	2
16		CABLE (not available as service part, see Item 26)	1
17	48948-18	NUT, Jam, 3/4"-16	1
18	51798	WASHER, Lock, Internal Tooth, 3/4"	1
19	51799-1	NUT, Knurled, 3/4"-16	1
20	51800	STRAP, Valve Adapter	1
21	48948-12	NUT, Jam, 5/16"-24	2
22	41903-15	PIN, Cotter, 3/32" x 3/4"	1
23	41902-20	PIN, Clevis, 5/16" x 1"	1
24	51804	CLEVIS	1
25	44743-1	SCREW, Socket Head, 1/4"-20 x 3/8"	4
26	51758-2	CABLE ASSEMBLY 60", (Includes Items 16 thru 24)	1
27	**	PIN, 1/4"	2
28	**	RETAINING RING, External, 1/4"	2
29	**	SCREW, Socket Head, 6MM-1.00 x 75MM	1
30	55578	* KIT, ASSY REPAIR (Includes Items 4-7 & 9)	1
31	55579	** KIT, PIN/CABLE RETAINER (Includes Items 10 & 27-29)	1
	51757	JOYSTICK ASSEMBLY (Includes Items 1-14 & 27-29)	1

Figure 2
Cable Harness

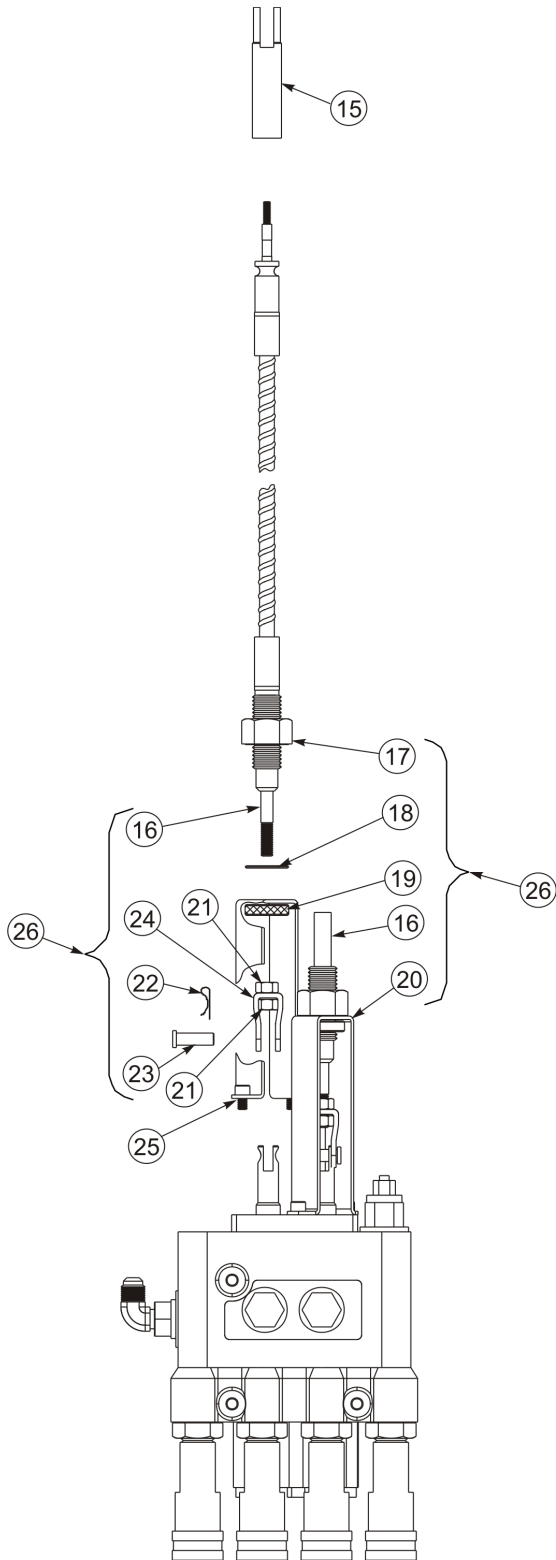
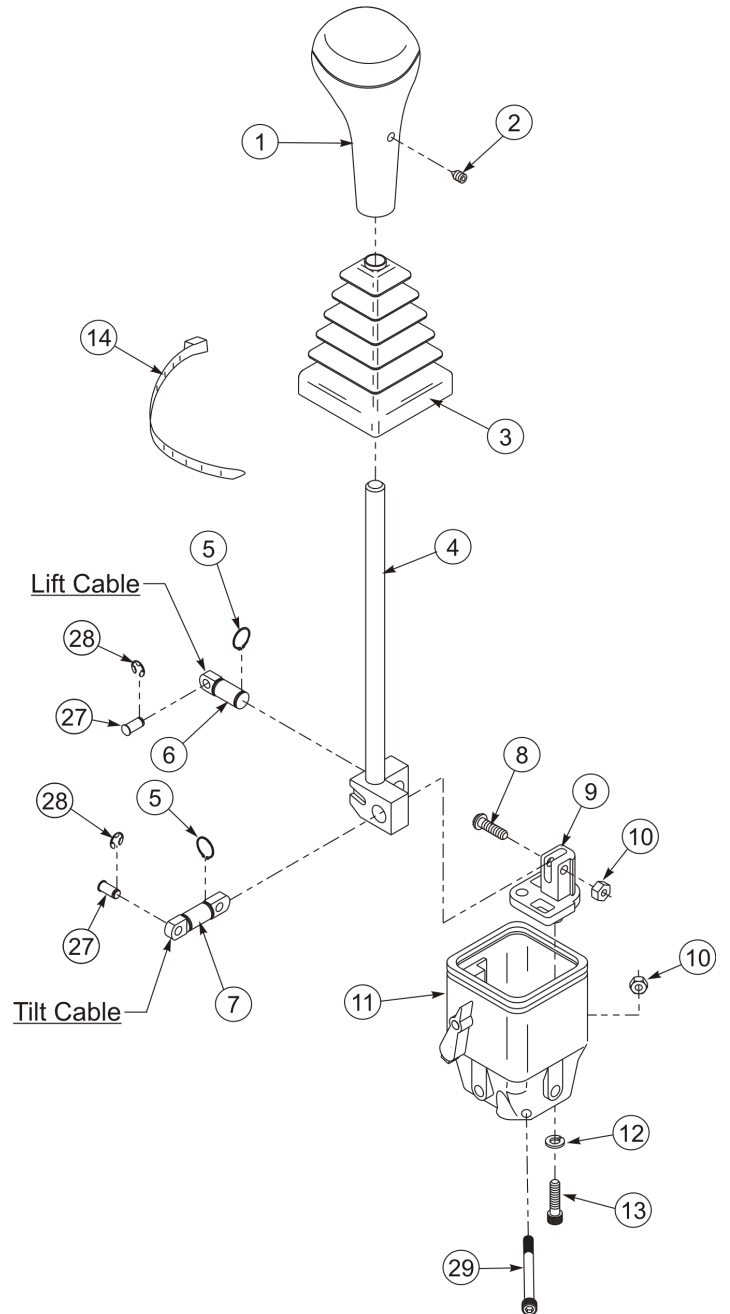

Figure 3
Joystick



JOYSTICK INSTALLATION - CAB MODEL (Figure 4)

1. Remove right rear tire.
2. Remove rubber plugs from inside of wheel well.
3. Using bottom hole as a guide, drill a 3/8" pilot hole through the foam padding in the cab. The hole should be within the 1" diameter pattern molded in the padding.
4. Lay the joystick mounting bracket (5) over the hole. Probe for the top hole in the fender through the top slot in the bracket (5). Enlarge the pilot holes to 7/8" maximum diameter and insert 1-1/4" round spacer (21) in the bottom hole. Insert the 2" round spacer (22) in the top hole. Temporarily fasten bracket (5), back plate (8), and spacers (21 & 22) using 3/8" x 3.00 carriage bolt (30), 3/8" x 2.25 carriage bolt (32), and 3/8" lock nut (29).
5. Drill a 7/16" diameter pilot hole through middle hole of back plate (8) and probe for middle slot opening in mount bracket (5).
6. Remove bracket (5) and enlarge middle hole to 7/8" maximum diameter. Place 1-1/2" round spacer (23) in hole. Refasten bracket (5), spacers (21, 22 & 23) and backing plate (8) using carriage bolts:

Top slot: 3/8" x 3.00 (30)

Middle slot: 3/8" x 2.50 (31)

Lower slot: 3/8" x 2.25 (32) and 3/8" lock nuts (29)

JOYSTICK INSTALLATION - ROPS MODEL (Figure 4)

1. Remove right rear tire.
2. Place paper template on right fender. Place in-line template holes approximately 22" from center line of tractor. Locate lower hole of template by measuring up approximately 15-1/2" from platform. Keep in-line holes of template as perpendicular to the platform as possible. Do not try to align holes with outside edge of fender.
3. Mark hole locations and drill three 7/16" diameter holes through fender.

4. Place rubber washers (24), 2" round spacer (22), 1/5" round spacer (23), 1.25" round spacer (21) and joystick mounting bracket (5) on fender. Place backing plate (8) on inside of wheel well and fasten all using carriage bolts:

Top slot: 3/8" x 3.00" (30)

Middle slot: 3/8" x 2.50" (31)

Lower slot: 3/8" x 2.25" (32) and 3/8" lock nuts (29)

JOYSTICK ASSEMBLY AND MOUNTING ON TRACTOR (Figures 3 & 4)

1. Remove rubber plug from right corner of tractor platform. Push cable control ends (2) through tractor platform, making sure cables are not twisted. (Figure 4).
2. Disassemble handle (1) and boot (3) from joystick assembly by loosening set screw (2) in handle (1) and lifting handle (1) and boot (3) from joystick lever. (Figure 3).
3. Remove socket head screw (29) and locknut (10) from lower side hole of base (11). (Figure 3).
4. Slide "lift cable" (16) and cable adapter (15) through rear hole on bottom of base (11). Attach cable adapter (15) to rod end (6) with pin (27) and retaining ring (28). (Figure 3).
5. Slide "tilt cable" (16) and cable adapter (15) through front hole on bottom of base (11). Attach cable adapter (15) to rod end (7) with pin (27) and retaining ring (28). (Figure 3).
6. Lock lift cable and tilt cable into place by reinstalling socket head screw (29) and locknut (10) through lower side hole of base (11).
7. Slide boot (3) onto joystick handle assembly and reinstall handle (1). (Figure 3).

JOYSTICK ASSEMBLY AND MOUNTING ON TRACTOR (CONTINUED)

8. Attach bracket (35) to joystick mounting bracket (5) using 5/16" x 1.00 bolts (34), 5/16" flat washers (28), and 5/16" lock nuts (33). Attach joystick assembly (3) to bracket (35) using 5/16" x 3-1/2" bolts (27), 5/16 flat washers (28), and 5/16" lock nuts (33). Adjust joystick for comfort and tighten 5/16" x 1.00 bolts (34). (Figure 4).
9. Adjust cables at valve to get desired performance from joystick, making sure cables and hose are not binding or coming into contact with any moving part. Attach hoses and cable to tractor steel lines under tractor frame with zip ties.
10. Coupler loader hoses to corresponding female couplers (15) on valve (1). It is important to make sure color coding corresponds between spiral bands and dust plugs on each hose. (Figure 4).
11. Bundle loader hoses with reusable strap (26) and secure to loader mount. (Figure 4).
12. After all plumbing has been completed, slowly cycle lift and bucket cylinders several times to purge air from hydraulic system. Retract cylinders and shut off engine. Replenish tractor hydraulic system.

NOTE: *When cycling loader, operate loader according to operation decal located on joystick knob. If directional control lever is wrong or loader will not lower, recheck connections shown.*



WARNING: *Escaping hydraulic fluid under pressure can have sufficient force to penetrate skin causing serious personal injury. If injured by escaping hydraulic fluid, obtain medical treatment immediately.*

JOYSTICK MOUNTING BRACKET TEMPLATE FULL SCALE ROPS APPLICATION

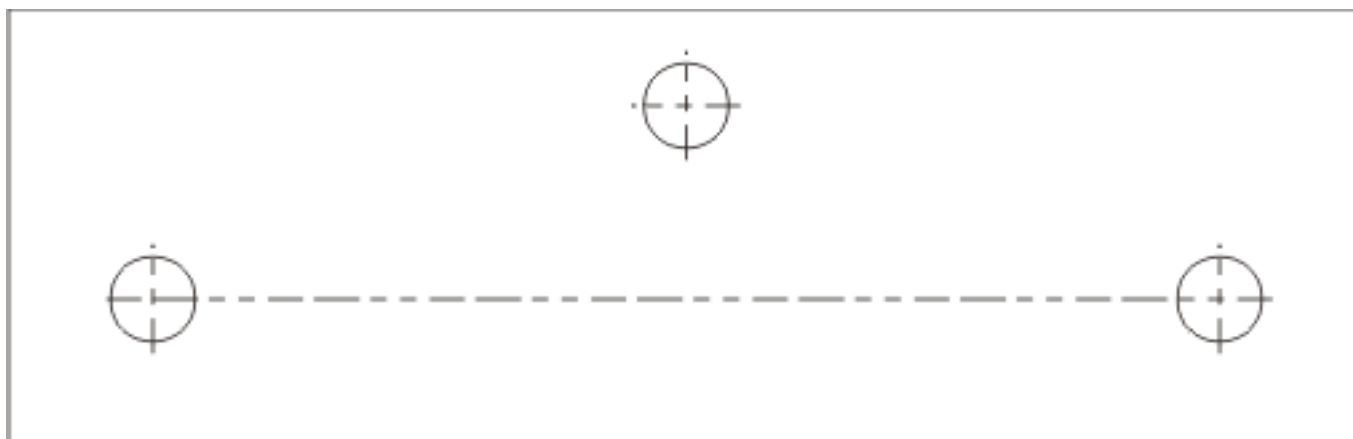

PARTS LIST - VALVE & PLUMBING KIT

ITEM	PART NO.	DESCRIPTION	QTY.
1	51813	VALVE, Prince LVR (3000 psi)	1
2	51758-1	CABLE ASSEMBLY	2
3	51757	JOYSTICK ASSEMBLY, INDEMAR	1
4	51763	MOUNT PLATE, Valve	1
5	51760	BRACKET, Joystick Mounting	1
6	41838-26	SCREW, Cap, 5/16"-18 x 3/4" YDP	6
7	41837-2	WASHER, Lock, 5/16" YDP	6
8	51761	BACKING PLATE	1
9	32845-2	FITTING, Elbow, 3/4"-16 JIC x 3/4"-16 O-ring, 90°	1
10	51476-3	HOSE, 1/2" x 60" Return (Tank and Pressure))	2
11	51765	COVER PLATE	1
12	51477-2	HOSE, 1/2" x 30" Power Beyond	1
13	42672-82	SCREW, Cap, 16MM-1.50MM x 120MM	2
14	41837-7	WASHER, Lock, 5/8"	2
15	6147-8	COUPLER, Quick, Female, 1/2 -14 YDP	4
16	36240-9	BAND, Spiral Plastic, 1" Blue	1
	36240-10	BAND, Spiral Plastic, 1" Red	1
	36240-11	BAND, Spiral Plastic, 1" Yellow	1
	36240-12	BAND, Spiral Plastic, 1" Green	1
17	39280-8	FITTING, Straight, 3/4"-16 O-ring x 1/2"-14 NPT	4
18	34853-42	SLEEVE, Nylon, 1-1/4" x 60	2
19	34853-58	SLEEVE, Nylon, 1-1/4" x 30	1
20	51518-3	SPACER, 1/2" Lg. YDP	1
21	50227-2	SPACER, 1-1/4" Lg. YDP	1
22	50227-4	SPACER, 2.00" Lg. YDP	1
23	50227-3	SPACER, 1-1/2" Lg. YDP	1
24	51764-1	WASHER, Rubber	3
25	8137-1	STRAP, Adjustable .19" x 11"	3
26	7438-1	STRAP, Tarp	1
27	41838-81	SCREW, Cap, 5/16"-18 x 3-1/2"	2
28	42502-7	WASHER, Flat, 5/16"	6
29	41840-3	NUT, Lock, 3/8"-16	3
30	41839-18	BOLT, Carriage, 3/8"-16 x 3.0 YDP	1
31	41839-17	BOLT, Carriage, 3/8"-16 x 2-1/2	1
32	41839-16	BOLT, Carriage, 3/8"-16 x 2-1/4	1
33	41840-2	NUT, Lock, 5/16"-18	4
34	41838-60	SCREW, Cap, 5/16"-18 x 1.00	2
35	52244	BRACKET, Adapter	1
36	46487-1	HOSE, .375" x 64.00"	4
37	6137-6	COUPLING ADAPTER, 1/2"-14	4

Figure 4
Valve & Plumbing Kit

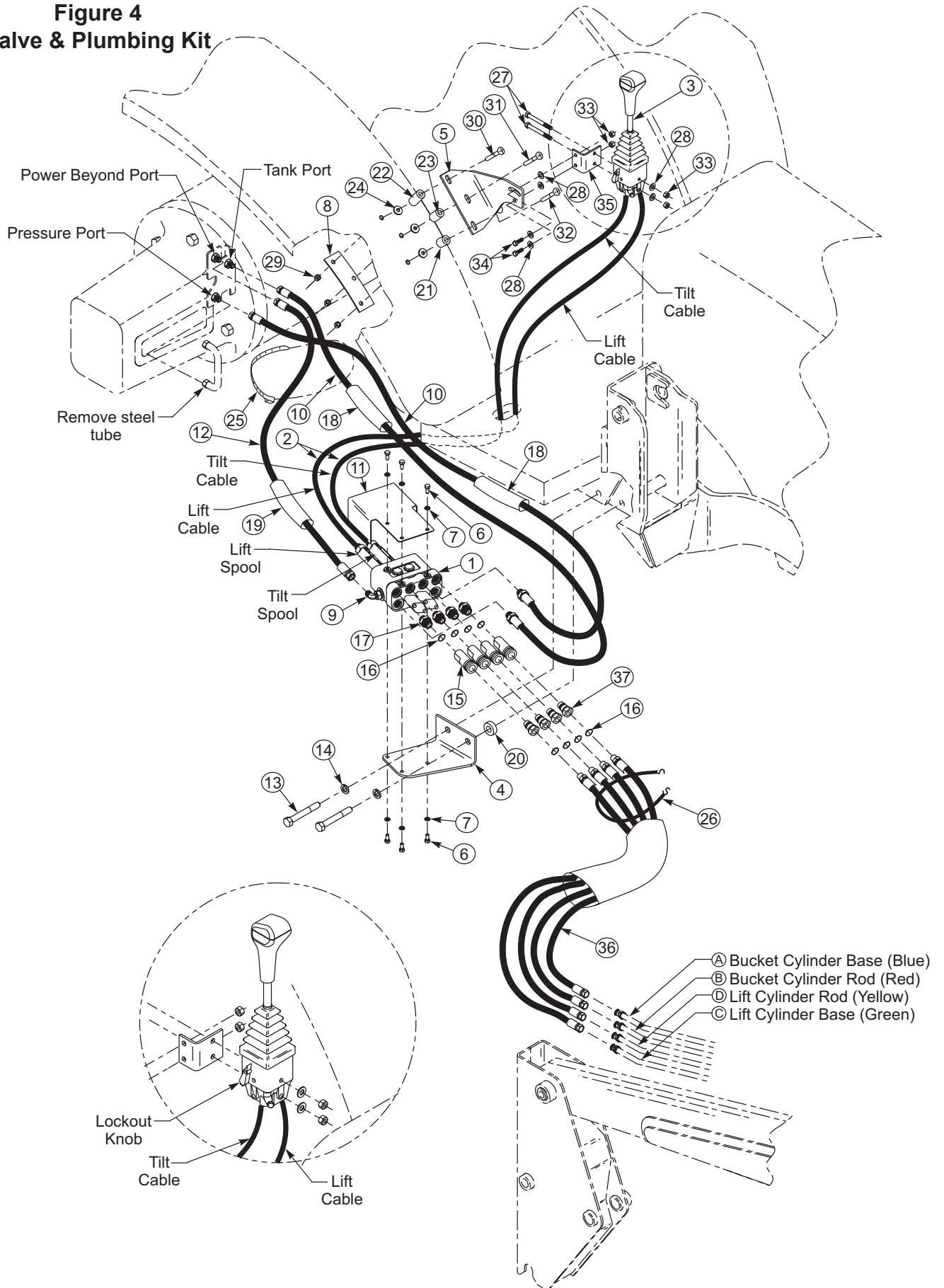

PRINCE LVR VALVE SERVICE

Following is an outline procedure for disassembling and reassembling valve.



WARNING: Valve has a valve relief setting preset at the factory. Tampering with this setting can cause serious injury to operator and damage to tractor or loader. Unauthorized adjustments or service to valve relief will VOID Warranty of both loader and tractor. If adjustments or service to valve relief are required during warranty period, an authorized service department must be consulted for authorization.

VALVE DISASSEMBLY (Figure 5)

NOTE: It is advisable to mark or tag all parts so they will be reinstalled in their proper position.

1. Remove hex head cap screws (13) and detent end caps (14) from both spools. Remove detent sleeve (12) from regen spool. Remove steel balls (20), poppet (21), and poppet spring (19) from detent retainer (24). Remove retaining flat (15) and detent spacer (16) from regen spool.
2. Secure handle end of regen spool. Using a rod through retainer ball holes, remove detent retainer (24) from regen spool.

NOTE: Detent retainers (18 & 24) are installed on spools using Loctite 222 or equivalent. If spool adapter comes loose instead of detent retainer, pull spool completely out of valve and secure spool using locking pliers (vise grips, for example) on land section of spool not machined for valve bore.
3. Remove washer (17), centering spring (26), and stop cup (23) from regen spool.
4. Holding in on float detent sleeve (22), push in on float spool from handle end and remove steel balls (20) from float detent retainer (18). Remove float detent sleeve (22), poppet (21), poppet spring (19), retaining flat (15) and spacer (16) from float spool.
5. Secure handle end of float spool. Using a rod through retainer ball holes, remove detent retainer (18) from float spool.

NOTE: Detent retainers (18 & 24) are installed on spools using Loctite 222 or equivalent. If spool adapter comes loose instead of detent retainer, pull spool completely out of valve and secure spool using locking pliers on land section of spool not machined for valve bore.

6. Remove washer (17), centering spring (26), and stop cup (23) from float spool.
7. Push spools in from cable end until rear spool seals (1) are exposed. Using wire hook and screwdriver, remove rear spool seals. Push spools in from the rear until front spool seals (1) are exposed. Using wire hook and screwdriver, remove front spool seals.
8. Clean all parts, including valve body, in suitable cleaning solvent. After cleaning parts with solvent, use air pressure to blow any dirt or excess solvent from all parts, including inside of valve body.

VALVE REASSEMBLY (Figure 5)

1. Examine all parts for wear and damage and replace if necessary.
2. Lubricate all O-rings and spools with oil to prevent damage when assembling.
3. Lubricate all detent and spring centering parts with a light coat of grease before disassembling.
4. Reassemble all parts in reverse order of disassembly.

NOTE: Use Loctite 222 or equivalent when installing detent retainers (18 & 24).

RELIEF VALVE, LOAD CHECK PLUGS, AND POWER BEYOND SLEEVE

NOTE: Relief valve (3), load check plugs (27), and power beyond sleeve (2) may be removed separately to clean, inspect, or replace parts without removing valve spools.

NOTE: If repairing or replacing relief valve (3), torque larger hex nut (relief body) to 20-25 ft.-lbs.

**Figure 5
Prince LVR Valve**

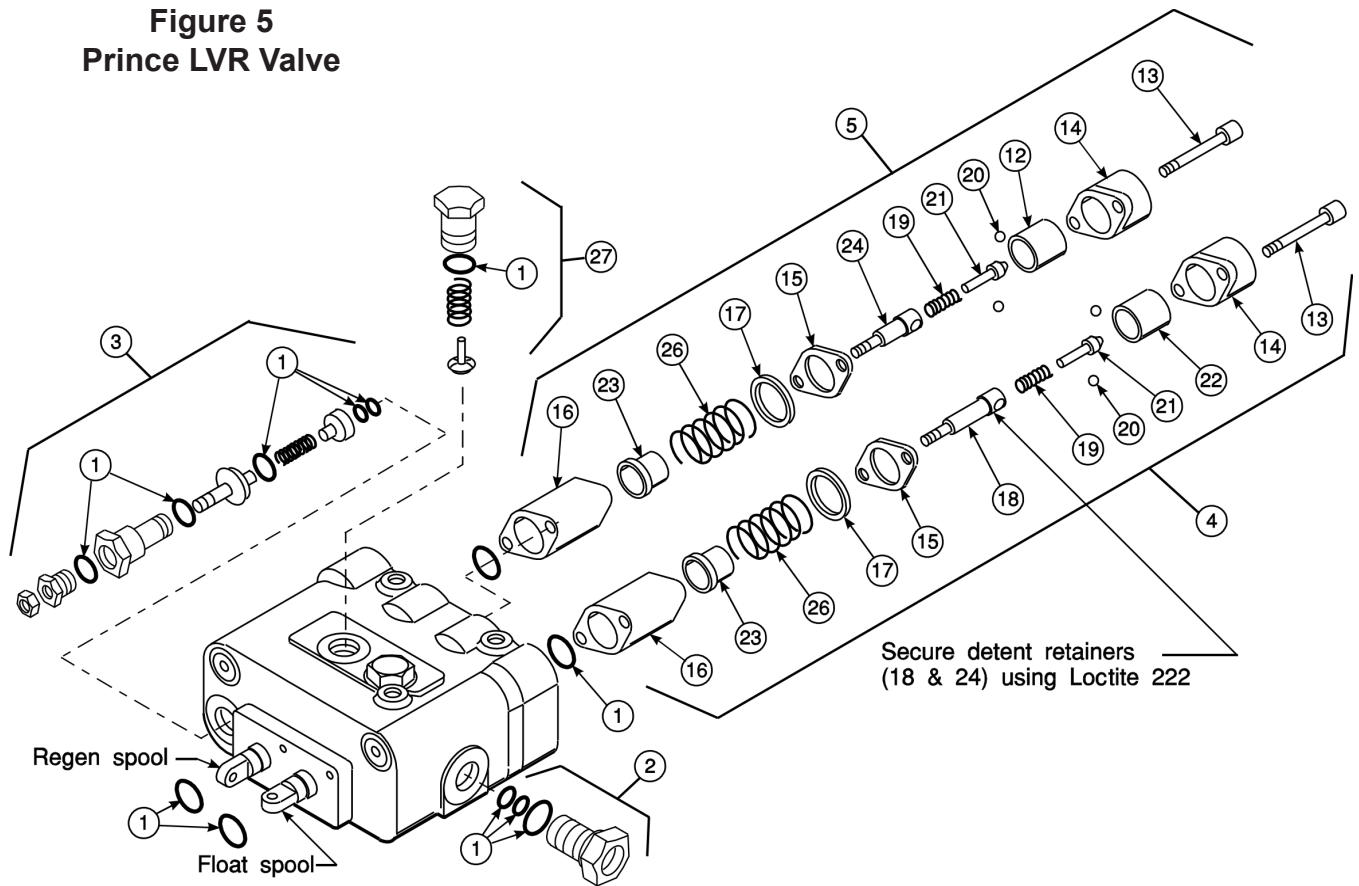

PARTS LIST - Prince LVR Valve







ITEM	PART NO.	DESCRIPTION	QTY.
1	43633	SEAL KIT, Valve, Prince LVR (3000 psi)	1
2	43636	POWER BEYOND SLEEVE	1
3	51813	RELIEF Valve (3000 psi)	1
4	43638	FLOAT KIT (Includes items 13,14, 15, 16, 17, 18, 19, 20, 21, 22, 23 & 26)	1
5	43639	REGEN KIT (Includes items 12, 13, 14, 15, 16, 17, 19, 20, 21, 24, & 26)	1
14	44476-6	END CAP (MFR's PN HC-V-AA23, stamped on end cap with valve & relief setting)	2

NOTE: Individual items not listed in repair parts listing are not available separately.

GENERAL TORQUE SPECIFICATIONS

USE THE FOLLOWING TORQUES WHEN SPECIAL TORQUES ARE NOT GIVEN

Standard American and Metric Cap Screws

AMERICAN STANDARD CAP SCREWS									METRIC CAP SCREWS										
5				8				Metric Class 8.8				10.9							
Typ. Head Markings 				Typ. Head Markings 				Typ. Head Markings  				Typ. Head Markings  							
TORQUE									TORQUE										
Size		FT-LBS		N·m		FT-LBS		N·m		Size		FT-LBS		N·m		FT-LBS		N·m	
Inches	MIN	MAX	MIN	MAX	MIN	MAX	MIN	MAX	MIN	MAX	Millimeters	MIN	MAX	MIN	MAX	MIN	MAX	MIN	MAX
1/4 - 20	6.25	7.25	8.5	10	8.25	9.5	11	13			M6 x 1.00	6	8	8	11	9	11	12	15
1/4 - 28	8	9	11	12	10.5	12	14	16			M8 x 1.25	16	20	21.5	27	23	27	31	36.5
5/16 - 18	14	15	19	20	18.5	20	25	27			M10 x 1.50	29	35	39	47	42	52	57	70
5/16 - 24	17.5	19	23	26	23	25	31	34			M12 x 1.75	52	62	70	84	75	91	102	123
3/8 - 16	26	28	35	38	35	37	47.5	50			M14 x 2.00	85	103	115	139	120	146	163	198
3/8 - 24	31	34	42	46	41	45	55.5	61			M16 x 2.50	130	158	176	214	176	216	238	293
7/16 - 14	41	45	55.5	61	55	60	74.5	81			M18 x 2.50	172	210	233	284	240	294	325	398
7/16 - 20	51	55	69	74.5	68	75	92	102			M20 x 2.50	247	301	335	408	343	426	465	577
1/2 - 13	65	72	88	97.5	86	96	116	130			M22 x 2.50	332	404	450	547	472	576	639	780
1/2 - 20	76	84	103	114	102	112	138	152			M24 x 3.00	423	517	573	700	599	732	812	992
9/16 - 12	95	105	129	142	127	140	172	190			M27 x 3.00	637	779	863	1055	898	1098	1217	1488
9/16 - 18	111	123	150	167	148	164	200	222			M30 x 3.00	872	1066	1181	1444	1224	1496	1658	2027
5/8 - 11	126	139	171	188	168	185	228	251											
5/8 - 18	152	168	206	228	203	224	275	304											
3/4 - 10	238	262	322	355	318	350	431	474											
3/4 - 16	274	305	371	409	365	402	495	544											
7/8 - 9	350	386	474	523	466	515	631	698											
7/8 - 14	407	448	551	607	543	597	736	809											
1 - 8	537	592	728	802	716	790	970	1070											
1 - 14	670	740	908	1003	894	987	1211	1337											

NOTE: These values apply to fasteners as received from supplier, dry or when lubricated with normal engine oil. They do not apply if special graphite or molysulphide greases or other extreme lubricants are used.

37° JIC Fittings

Size	Thread Size	Assembly Torque		Tube Connection F. F. F. T.	Swivel Nut or Hose Connection F. F. F. T.
		in.·lb.	ft.·lb.		
-4	7/16 - 20	140 ± 10	12 ± 1	2	2
-5	1/2 - 20	180 ± 15	15 ± 1	2	2
-6	9/16 - 18	250 ± 15	21 ± 1	1 1/2	1 1/4
-8	3/4 - 16	550 ± 25	45 ± 5	1 1/2	1
-12	1 1/16 - 12	1000 ± 50	85 ± 5	1 1/4	1
-16	1 5/16 - 12	1450 ± 50	120 ± 5	1	1
-20	1 5/8 - 12	2000 ± 100	170 ± 10	1	1
-24	1 7/8 - 12	2400 ± 150	200 ± 15	1	1
-32	2 1/2 - 12	3200 ± 200	270 ± 20	1	1

O-Ring Face Seal Tube/ Hose Swivel Nut

Metric Tube O.D. (mm)	Dash Size	Thread Size (in.)	Swivel Nut Hex Size (in.)	Swivel Nut Torque	
				N·m	lb·ft
5	-3	--	--	--	--
6	-4	9/16 - 18	11/16	16	12
8	-5	--	--	--	--
10	-6	11/16 - 16	13/16	24	18
12	-8	13/16 - 16	15/16	50	37
16	-10	1 - 14	1-1/8	69	51
20	-12	1-3/16 - 12	1-3/8	102	75
22	-14	1-3/16 - 12	--	102	75
25	-16	1-7/16 - 12	1-5/8	142	105
32	-20	1-11/16 - 12	1-7/8	190	140
38	-24	2 - 12	2-1/4	217	160
50.8	-32	--	--	--	--

SAE O-Ring Fittings

Size	Swivel Nut or Hose	Assembly Torque		F. F. F. T.
		in.·lb.	ft.·lb.	
2	5/16 - 24	90 ± 5	7.5 ± 0.5	1 ± .25
3	3/8 - 24	170 ± 10	14 ± 1	1 ± .25
4	7/16 - 20	220 ± 15	18 ± 1	1 ± .25
5	1/2 - 20	260 ± 15	22 ± 1	1 ± .25
6	9/16 - 18	320 ± 20	27 ± 2	1.5 ± .25
8	3/4 - 16	570 ± 25	48 ± 2	1.5 ± .25
10	7/8 - 14	1060 ± 50	90 ± 5	1.5 ± .25
12	1 1/16 - 12	1300 ± 50	110 ± 5	1.5 ± .25
14	1 3/16 - 12	1750 ± 75	145 ± 6	1.5 ± .25
16	1 5/16 - 12	1920 ± 125	160 ± 6	1.5 ± .25
20	1 5/8 - 12	2700 ± 150	225 ± 12	1.5 ± .25
24	1 7/8 - 12	3000 ± 150	250 ± 12	1.5 ± .25
32	2 1/2 - 12	3900 ± 200	325 ± 15	1.5 ± .25

INSTALLATION INSTRUCTIONS