

Keep with Operator's Manual
-----------------------------

## LOADER MOUNTING KIT 4211 & 4211 MSL LOADER CASE IH TRACTOR

MODEL	2WD	FWA	ROPS	CAB
JX95	X	X	X	X

### TRACTOR AND MOUNTING KIT GENERAL INFORMATION

“MSL” refers to mechanical self leveling.

Mounting kit can be installed on tractor using tools ordinarily available, including an overhead hoist with sling, floor jack, standard and metric wrenches, and a torque wrench. For cab-equipped tractor, a clean container will be needed to catch and reuse contents of tractor engine cooling system.

Mounting kit is not compatible with front weights. If front weights are present, remove them before installing loader mounting brackets.

Tractor-supplied hydraulic power is required for loader mounting and operation. Two hydraulic hose kit options are available, one includes hoses and fittings required to plumb loader hydraulics to tractor mid-mounted valve couplings and the other includes hoses and fittings required to plumb loader hydraulics to tractor rear remote valve couplers. Select the appropriate hose kit for your tractor remote control valve location.

Loader mounting kit is not compatible with front fenders. If tractor is equipped with front fenders, remove tractor front fenders and attaching hardware before installing loader mounting brackets.

Tractor steering stops need to be adjusted to allow a minimum tire clearance of 3/4" between front tire and loader or mounting brackets on full left or right turn with front axle fully oscillated and loader lift cylinders fully retracted. Refer to tractor operator's manual for information about adjusting tractor steering stops.

Shut off engine and engage brakes during installation.



**CAUTION:** Support mounting brackets when unbanding from pallet.

**NOTE:** Install all attaching hardware loose (unless noted otherwise) until mounting kit is completely assembled to facilitate assembly and proper alignment. Unless otherwise specified, tighten all hardware to torques specified in general torque specifications table included in loader operator's manual.

### PREPARING TRACTOR FOR LOADER MOUNTING BRACKET INSTALLATION

1. For tractors with cab-mounted toolbox, temporarily remove toolbox during loader mounting bracket installation. (Toolbox may be reinstalled after mid mounting brackets have been installed).
2. Temporarily remove exhaust stack, extension tube, and supporting bracket. Install spacer (5) in place of supporting bracket using previously removed hardware. Save remaining hardware for exhaust stack relocation.

### INSTALLING LOADER LEFT MID MOUNTING BRACKET (Figure 1)

**CAB MODELS ONLY** - Radiator hoses need to be rerouted to avoid interference with left mid mounting bracket. Place a clean container under radiator to catch coolant. Temporarily remove two 1" radiator heater hoses from radiator side and drain contents of cooling system into container, to be reused. Slip sleeve (17) over radiator hoses.

1. Support left side of tractor cab or platform. Place a floor jack under front inside corner of fuel tank and remove support flat from bottom of tractor and step. Temporarily remove bottom step to gain better access to fuel tank and support brackets for cab or platform.
2. Remove lower 16mm cap screw and remove spacer block. Tilt fuel tank forward and slide slightly away to gain access to upper lift 16mm cap screw. Remove cap screws and spacer block. Keep hardware for later reuse.
3. Place a clevis loop over top inside bushing of left mid mounting bracket (1) and secure. Using an overhead hoist, hook clevis loop and raise into position.
4. Slide rear of left mid mounting bracket (1) between transmission casting and plate which supports cab or platform. Attach rear of left mid bracket (1) reusing previously removed hardware. Place one 16mm x 100mm cap screw (11) and 5/8" lock washer (12) in remaining hole.

## INSTALLING LOADER LEFT MID MOUNTING BRACKET *(Continued)*

- Place 1-3/4" long spacers (6) between rear pair of slotted holes at front of left mid mounting bracket (1) and side of tractor front casting. Place spacer plate (8) and 1-1/4" long spacers (7) between front-most pair of slotted holes and side of tractor front casting.

**NOTE:** *If grille guard is to be installed, do not use spacer plates (8) in front-most pairs of holes. Grille guard mounting brackets take the place of spacer plates (8) on each side of tractor front casting. Refer to instructions provided with grille guard kit.*

- Secure left mid mounting bracket (1) and spacers (or grille guard) to tractor front casting using 16mm x 100mm cap screws (11), 5/8" flat washers (13), and 5/8" lock washers (12).

**CAB MODELS ONLY** - Slip radiator hoses and sleeve (17) through slot in left mid mounting bracket (1). Adjust sleeve (17) to conform to slot and place tie straps (16) on either end of sleeve (17) to lock it into place. Reinstall hoses to radiator. Refill radiator with previously drained coolant.

- Reinstall step and fuel tank brackets. Remove temporary supports which are no longer needed.
- Install exhaust bracket (3) to left mid mounting bracket (1) using 1/2" x 1-1/2" cap screws (14) and 1/2" hex nuts (15).
- Place exhaust extension tube (4) onto tractor exhaust manifold and turn toward exhaust bracket (3).
- Attach exhaust extension tube (4) to tractor exhaust manifold using previously-removed hardware.
- Place exhaust stack onto exhaust extension tube (4) and secure to exhaust bracket U-clamp (3) using previously removed hardware.

## INSTALLING LOADER RIGHT MID MOUNTING BRACKET (Figure 1)

- Support right side of cab or platform. Remove three 16mm cap screws which support the cab or platform. Keep hardware for later use. Remove spacer blocks.
- Place a clevis loop over top inside bushing of right mounting bracket (2) and secure. Using an overhead hoist, hook clevis loop and raise into position.
- Slide rear of right mid mounting bracket (2) between transmission casting and plate which supports cab or platform. Attach rear of right mid mounting bracket (2) reusing previously removed hardware. Place one 16mm x 100mm cap screw (11) and 5/8" lock washer (12) in remaining hole.
- Place 1-3/4" long spacers (6) between rear pair of slotted holes at front of right mid mounting bracket (2) and side of tractor front casting. Place spacer plate (8) and 1-1/4" long spacers (7) between front-most pair of slotted holes and side of tractor front casting.

**NOTE:** *If grille guard is to be installed, do not use spacer plates (8) in front-most pairs of holes. Grille guard mounting brackets take the place of spacer plates (8) on each side of tractor front casting. Refer to instructions provided with grille guard kit.*

- Secure right mid mounting bracket (2) and spacers (or grille guard) to tractor front casting using 16mm x 100mm cap screws (11), 5/8" flat washers (13), and 5/8" lock washers (12).
- Making sure rear surface of right mid mounting upright is clean and dry, remove backing from danger decal (21) and apply to upright near top where it will be visible to the operator.
- Tighten all cap screws to specified torques and remove temporary cab or platform support. Reinstall tractor toolbox for tractors equipped with cab toolbox.
- Install left and right axle oscillation stops (19 & 20) using 16mm x 30mm bolts (18) and 5/8" lock washers (12).
- Start engine and check for coolant leaks.

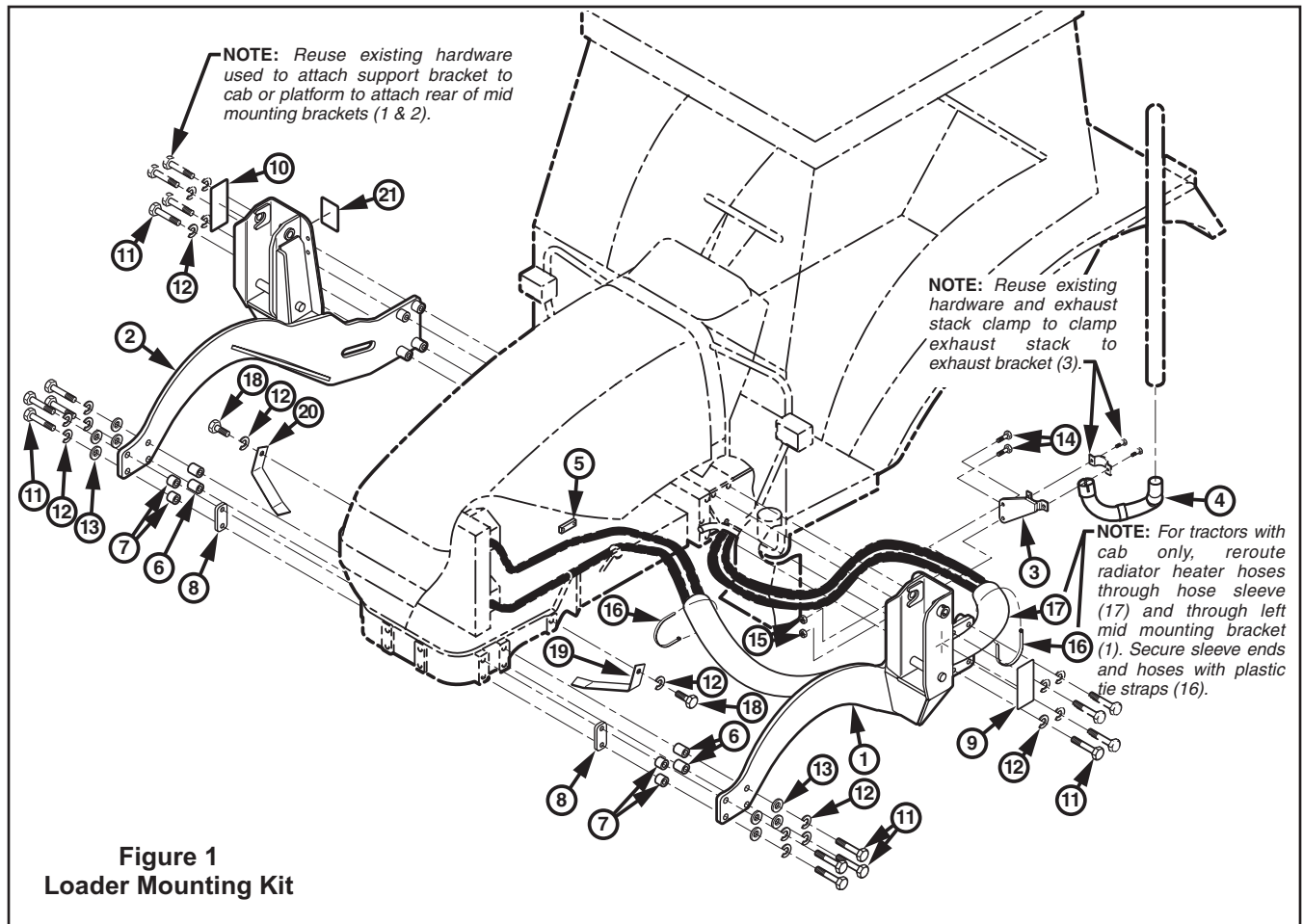

## PARTS LIST – MOUNTING KIT

Item	Part No.	Description	Qty.
1	52749-1	BRACKET, Mid Mounting, Left, with Decal (Includes item 9.)	1
2	52749-2	BRACKET, Mid Mounting, Right, with Decal (Includes item 10.)	1
3	51481	BRACKET, Exhaust Support	1
4	51480	TUBE, Exhaust Extension	1
5	51479	PLATE, Exhaust Spacer	1
6	51518-1	SPACER, Tube, 1-3/4" Long	4
7	51518-2	SPACER, Tube, 1-1/4" Long	4
8	51491	SPACER, Plate, Front	2
9	46776	DECAL, WARNING, Loader Safety (Included with item 1.)	1
10	51902	DECAL, WARNING, Avoid Injury During Removal or Reinstall (Included with item 2.)	1
11	42672-28	SCREW, Cap, Hex Head, 16mm-1.50 x 100mm Grade 8.8	10
12	41837-7	WASHER, Lock, 5/8"	10
13	42502-32	WASHER, Flat, 5/8"	8
14	41838-33	SCREW, Cap, Hex Head, 1/2-13 x 1-1/2" Grade 5	2
15	41836-5	NUT, Hex, 1/2-13	2
16	8137-3	STRAP, Tie, Adjustable Plastic	2
17	34853-81	SLEEVE, 2-3/8" I.D. x 10"	1
18	42672-90	SCREW, Cap, Hex Head, 16mm-1.50 x 30mm GR 8.8	2
19	52602-1	OSCILLATION STOP, Left	1
20	52602-2	OSCILLATION STOP, Right	1
21	48858	DECAL, DANGER, Avoid Overhead Lines (Apply to rear surface of upright, item 2.)	1

**MOUNTING 4211 LOADER (Figures 2, 3 & 4)**

**WARNING:** Loader must be supported before removing hardware securing loader to shipping pallet, or loader will tip over.



**WARNING:** To avoid injury during installation of quick attach loader, do not permit bystanders within ten feet of loader.



**WARNING:** To avoid injury during installation of quick attach loader, an overhead hoist must be used for initial mounting. Parking stands are not operational without attachment mounted.

1. Loop chain under each bucket cylinder and hook on loader boom arm (see figure 2A). Using overhead hoist to support loader, remove cotter pins (A), hitch pins (B) and linch pins (C) (see figure 3). Discard cotter pins only. Remove hardware securing loader to pallet. Lift loader.

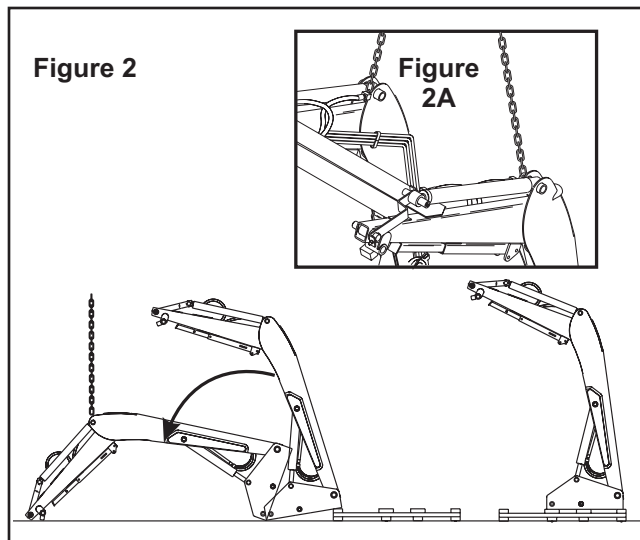

**CAUTION:** Loader uprights may rotate downward when loader is lifted from pallet.

2. Position pallet at rear of loader to facilitate lowering (see figure 2). Lower loader from vertical shipping position to horizontal position (scraps of cardboard may be used to protect paint). Remove 3/8" cap screws (D figure 3), lock nuts (E), pins (F), shipping brackets (G). Discard shipping brackets, retain hardware for further use. Remove bucket level indicator rod, which is attached to oil lines for shipment.
3. Remove tie straps (H) from hydraulic hoses. Route hoses through hose loop (I) on inside of loader upright (shown in figure 3). Secure a hoist strap around boom arm assembly or secure with a chain hook into hole (J), if so provided in underside of boom arm (see figure 4). If using a strap, strap should be located around boom arm at

approximately same location as chain shown in figure 4. Be sure to keep strap under oil lines on right side of boom.

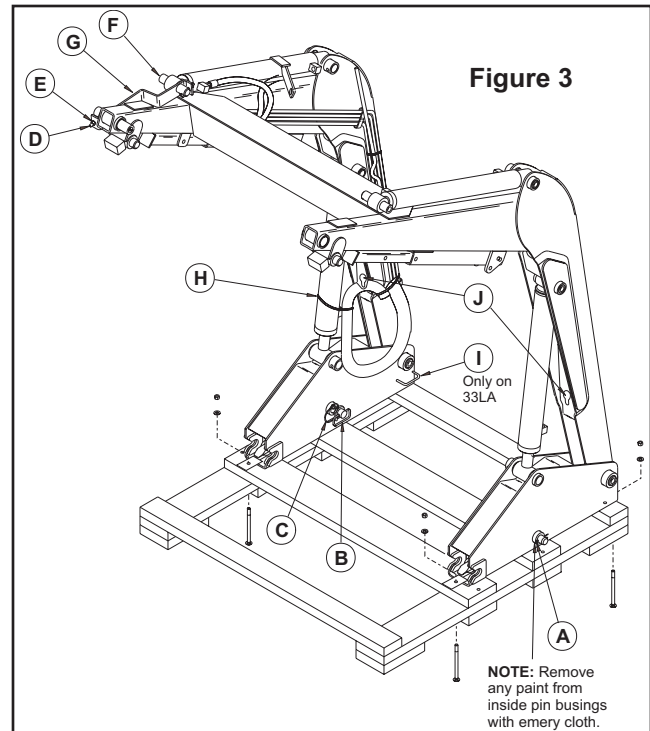

4. Raise loader with overhead hoist as shown in figure 4.

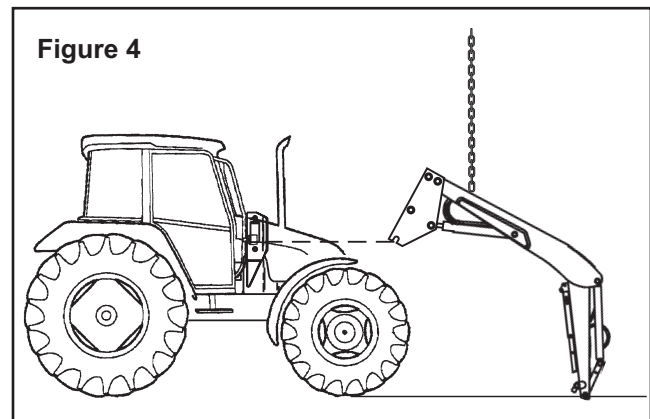

**NOTE:** Install valve kit or hose kit onto tractor before proceeding to instruction 5 on page 6.

(Continued on Page 6)

**MOUNTING 4211 MSL LOADER (Figures 5, 6 & 7)**

**WARNING:** Loader must be supported before removing hardware securing loader to shipping pallet, or loader will tip over.



**WARNING:** To avoid injury during installation of quick attach loader, do not permit bystanders within ten feet of loader.



**WARNING:** To avoid injury during installation of quick attach loader, an overhead hoist must be used for initial mounting. Parking stands are not operational without attachment mounted.

1. Loop hoist strap or chain around crossmember (see figure 5A). Using overhead hoist to support loader, remove shipping angle braces (C figure 6) by removing 1/2" lock nut (A), lift off brace (C), then reinstalling 1/2" lock nut that has been installed up to this point and (A).

**NOTE:** There is an additional 1/2" flat washer on outside of brace for shipping only, Remove and discard it with shipping angle brace.

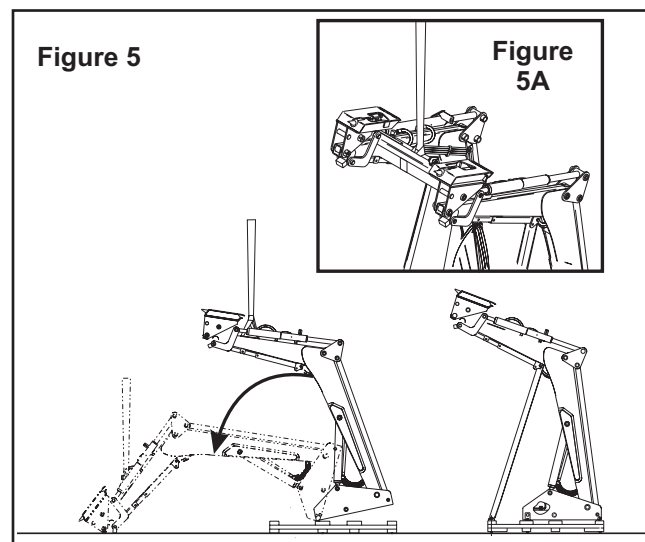

**NOTE:** Do not over tighten lock nut (A). Parking stand tube must pivot freely.

Remove remaining hardware (D figure 6) from shipping braces (C) and discard braces and hardware. Remove cotter pins (E), hitch pins (G) and linch pins (F). Discard only cotter pins. Then remove nuts and washers (D) from bolts securing loader to pallet.

2. Lower loader from vertical shipping position to horizontal position (figure 5) (Loader may require slight push to start lowering). Packaging hardware

may bend during lowering process, which is acceptable. Remove bucket level indicator rod, which is attached to oil lines for shipment.

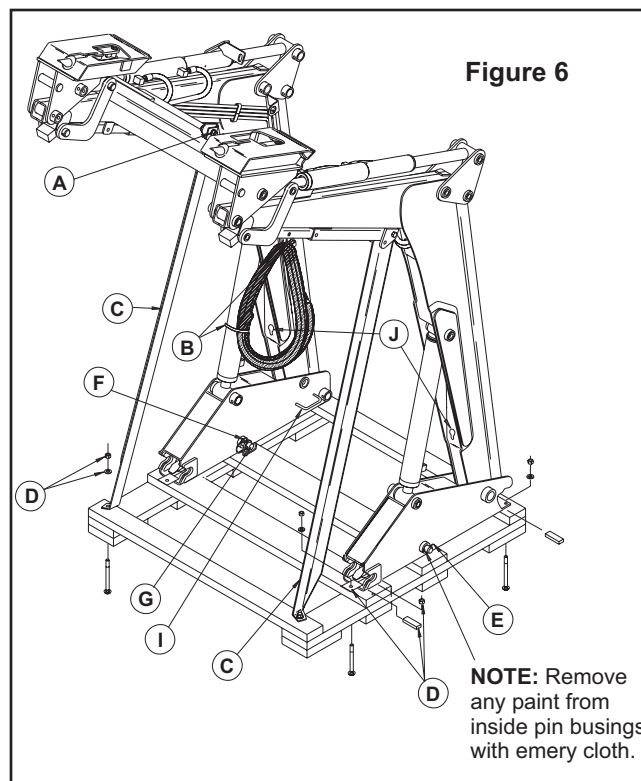

3. Remove tie straps (B) from hydraulic hoses. Route hoses through hose loop (I) on inside of loader upright (shown in figure 6). Secure a hoist chain hook into hole (J) provided in boom underside (refer to figures 6 & 7).
4. Raise loader with overhead hoist as shown in figure 7.

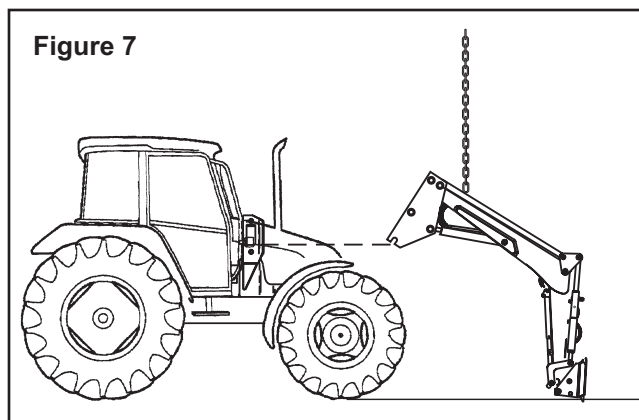

**NOTE:** Install valve kit or hose kit onto tractor before proceeding to instruction 5 on page 6.

(Continued on Page 5)

## MOUNTING 4211 & 4211 MSL LOADERS (Continued)

**NOTE:** Examine pin bushings and remove any paint with emery cloth before mounting loader (see figures 1, 3 & 6).

**NOTE:** Before continuing mounting procedure, lubricate loader as instructed in loader manual.

5. A) If tractor is equipped with a hose kit, back tractor up to rear of loader. Attach lift cylinder function hoses (color-coded green and yellow) to tractor rear remotes. Retract lift cylinders fully and continue to activate control lever for approximately 10 seconds.

B) If tractor is equipped with a valve kit, park tractor next to loader so right side of tractor cab window is parallel with rear of loader upright. Attach colored spiral bands to valve female couplers to identify hoses (Refer to valve kit instructions). Attach lift cylinder function hoses (color-coded green and yellow) to corresponding valve couplers. Retract lift cylinders fully and continue to activate control lever for approximately 10 seconds.

**NOTE:** It is important to attach lift cylinder hoses (color-coded yellow and green with identification bands) for loader to function properly.

Extend lift cylinders about 2" from fully closed position. Shut off tractor and disconnect hydraulic hoses.

Position tractor directly behind loader. Slowly raise loader with overhead hoist until loader upright will clear tractor front tires.

6. Move tractor forward until loader upright saddles are centered over mounting shaft. Lower loader with overhead hoist until upright saddle straddles mounting shaft.
7. Remove hoist chain or strap from loader boom and secure around front crossmember (see figure 9). Using overhead hoist raise front of loader to rotate loader upright into mounting pocket. Continue to rotate loader upright until upright has fully rotated into back of mounting guide. Insert two 1x 7-3/4 pins and linch pins which were removed from loader uprights in step 1, to secure loader to loader mountings.

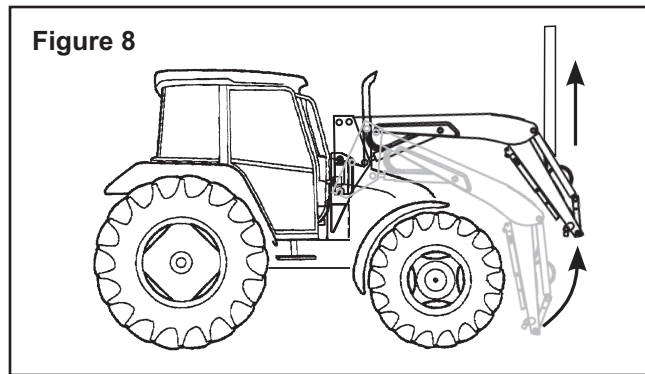

8. Connect hoses to tractor hydraulics. Refer to instructions provided with hose kit for tractors using rear remotes. Refer to valve kit instructions for tractors with auxiliary valve kit.
9. Start engine and slowly cycle cylinders several times to purge air from hydraulic system. Refer to hydraulic oil specifications in tractor operator's manual to replenish tractor hydraulic system.
10. Adjust front wheel tread settings or steering stops, if necessary to provide a minimum 3/4 inch clearance between front tires and any part of loader with lift cylinders fully retracted and front axle fully oscillated. Be sure lift cylinders are fully retracted. Refer to tractor operator's manual for tread setting and steering stop adjustment procedures.

### INSTALLING BUCKET OR ATTACHMENT

Refer to loader operator's manual to install bucket or optional attachment.

### ATTACH BUCKET LEVEL INDICATOR

Refer to instruction sheet and assembly manual with bucket or optional attachment for instructions to attach and adjust level indicator for bucket or attachment.

# GENERAL TORQUE SPECIFICATIONS

USE THE FOLLOWING TORQUES WHEN SPECIAL TORQUES ARE NOT GIVEN

## Standard American and Metric Cap Screws

AMERICAN STANDARD CAP SCREWS									METRIC CAP SCREWS								
SAE Grade	5				8				Metric Class	8.8				10.9			
Typ. Head Markings									Typ. Head Markings								
Cap Screw	TORQUE				TORQUE				Cap Screw	TORQUE				TORQUE			
Size	FT-LBS		N-m		FT-LBS		N-m		Size	FT-LBS		N-m		FT-LBS		N-m	
Inches	MIN	MAX	MIN	MAX	MIN	MAX	MIN	MAX	Millimeters	MIN	MAX	MIN	MAX	MIN	MAX	MIN	MAX
1/4 - 20	6.25	7.25	8.5	10	8.25	9.5	11	13	M6 x 1.00	6	8	8	11	9	11	12	15
1/4 - 28	8	9	11	12	10.5	12	14	16	M8 x 1.25	16	20	21.5	27	23	27	31	36.5
5/16 - 18	14	15	19	20	18.5	20	25	27	M10 x 1.50	29	35	39	47	42	52	57	70
5/16 - 24	17.5	19	23	26	23	25	31	34	M12 x 1.75	52	62	70	84	75	91	102	123
3/8 - 16	26	28	35	38	35	37	47.5	50	M14 x 2.00	85	103	115	139	120	146	163	198
3/8 - 24	31	34	42	46	41	45	55.5	61	M16 x 2.50	130	158	176	214	176	216	238	293
7/16 - 14	41	45	55.5	61	55	60	74.5	81	M18 x 2.50	172	210	233	284	240	294	325	398
7/16 - 20	51	55	69	74.5	68	75	92	102	M20 x 2.50	247	301	335	408	343	426	465	577
1/2 - 13	65	72	88	97.5	86	96	116	130	M22 x 2.50	332	404	450	547	472	576	639	780
1/2 - 20	76	84	103	114	102	112	138	152	M24 x 3.00	423	517	573	700	599	732	812	992
9/16 - 12	95	105	129	142	127	140	172	190	M27 x 3.00	637	779	863	1055	898	1098	1217	1488
9/16 - 18	111	123	150	167	148	164	200	222	M30 x 3.00	872	1066	1181	1444	1224	1496	1658	2027
5/8 - 11	126	139	171	188	168	185	228	251									
5/8 - 18	152	168	206	228	203	224	275	304									
3/4 - 10	238	262	322	355	318	350	431	474									
3/4 - 16	274	305	371	409	365	402	495	544									
7/8 - 9	350	386	474	523	466	515	631	698									
7/8 - 14	407	448	551	607	543	597	736	809									
1 - 8	537	592	728	802	716	790	970	1070									
1 - 14	670	740	908	1003	894	987	1211	1337									

**NOTE:** These values apply to fasteners as received from supplier, dry or when lubricated with normal engine oil. They do not apply if special graphite or moly sulphide greases or other extreme lubricants are used.

**⚠ WARNING**

**LOADER SAFETY**



Know all operation, warning and safety instructions in the operator's manual before operating the loader.

- Operate loader only from operator's seat.
- Carry bucket low during transport for better visibility and to avoid overturns.
- Use wheel ballast and / or rear weight for stability as recommended in the operator's manual.
- When parking or servicing unit, lower the bucket to the ground, stop engine, and set the parking brake to avoid tractor movement.

Failure to follow any of the instructions above can cause serious injury to the operator or other persons in are.

(Replacement manuals are available from your dealer.)

46776

**46776 — Item 9  
Warning Decal  
Left Mid Mounting Upright**

**⚠ WARNING**

**TO AVOID INJURY DURING REMOVAL OR REINSTALLATION OF LOADER**



Read and understand instructions in operator's manual

- Make sure detached loader is parked on hard, level ground.
- Always have a bucket mounted to loader when it is removed from tractor.
- Do not permit bystanders within 10 feet of loader.
- Do not remove bucket or repair loader if it is not mounted on tractor. Failure to comply could cause loader to collapse.

Failure to follow above instructions can cause serious injury.

51902

**51902 — Item 10  
Warning Decal  
Right Mid Mounting Upright**

**⚠ DANGER**

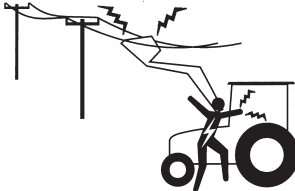

• Keep bucket and boom away from overhead electric lines. Failure to comply will result in serious injury or death.

48858

**48858 — Item 21  
Danger Decal  
Rear Surface of Right Mid Mounting Bracket**

# **INSTALLATION INSTRUCTIONS**