

Keep With Operator's Manual

## ALAMO SMC & RHINO 65A, 75 & 85 BACKHOE MOUNTING KIT KIOTI DX 45S TRACTOR

### TRACTOR AND SUBFRAME KIT GENERAL INFORMATION

Subframe kit can be installed on tractor using tools ordinarily available, including standard and metric wrenches and a torque wrench.

Complete backhoe mounting requires subframe channel kit 2-6509. Tractor must be equipped with 2409 Alamo SMC, Rhino loader, or Kubota LA703 front end loader.

**IMPORTANT:** Remove lynch pins and disconnect supports to disable 3-point hitch arms.

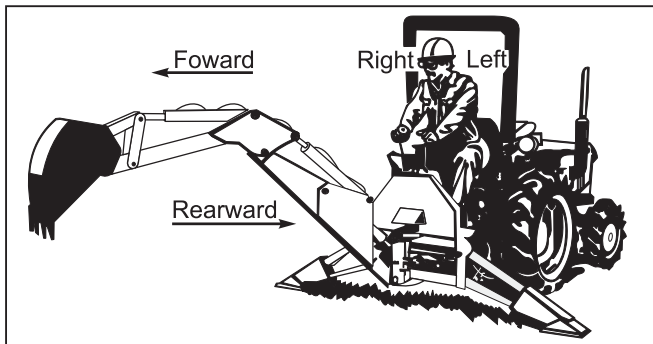

**NOTE:** References to right, left, forward and rearward directions are determined from the backhoe operator seat position facing rearward.



The backhoe is shipped partially assembled. Assembly will be easier if components are aligned and loosely assembled before tightening hardware.



Keep all persons away from operator control area while performing adjustments, service, or maintenance.



Keep hands and body away from pressurized lines. Use paper or cardboard, not hands or other body parts to check for leaks. Wear safety goggles. Hydraulic fluid under pressure can easily penetrate skin and will cause serious injury or death.



Make sure that all operating and service personnel know that if hydraulic fluid penetrates skin, it must be surgically removed as soon as possible by a doctor familiar with this form of injury or gangrene, serious injury, or death will result. **CONTACT A PHYSICIAN IMMEDIATELY IF FLUID ENTERS SKIN OR EYES. DO NOT DELAY.**

Always wear relatively tight and belted clothing to avoid getting caught in moving parts. Wear sturdy, rough-soled work shoes and protective equipment for eyes, hair, hands, hearing, and head and respirator or filter mask where appropriate.

**NOTE:** Leave all attaching hardware loose until mounting kit is completely assembled to facilitate assembly and proper alignment. Tighten all hardware to torques specified in general torque specifications table.

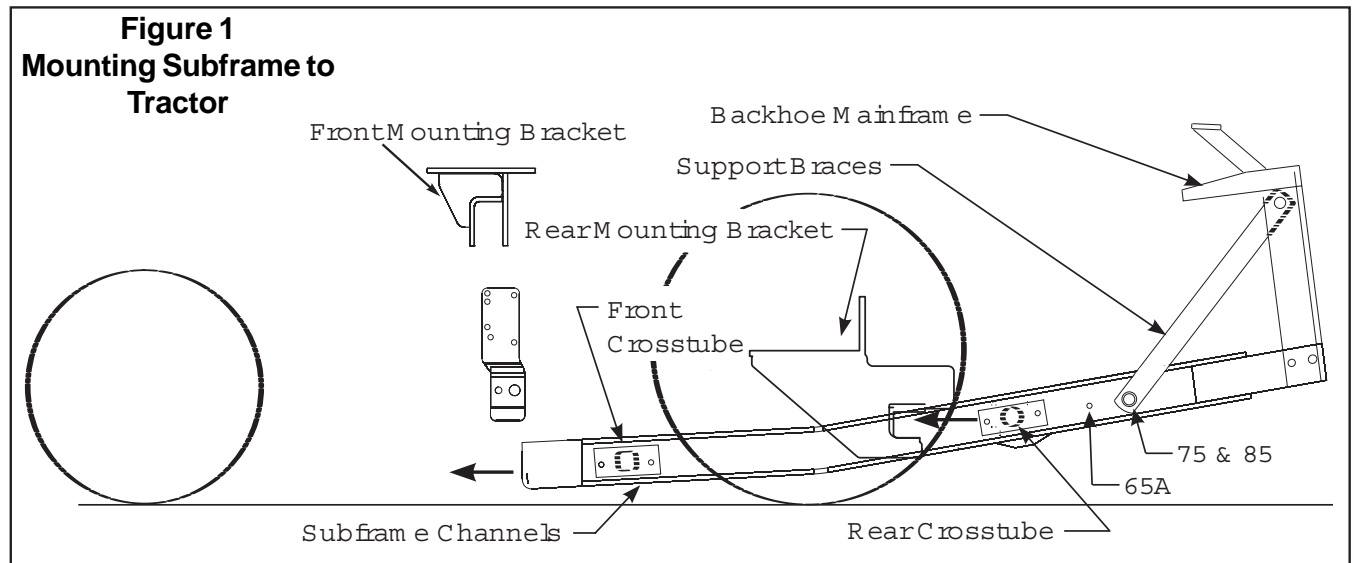

## 2-7527

### TRACTOR PREPARATION

1. Remove drawbar from tractor hitch bracket.
2. Remove tractor hitch bracket from tractor. Retain nuts from studs.

### INSTALLING MOUNTING BRACKETS (Figure 2)

1. Remove five rear bolts from left and right loader midmounting. Fasten left (1) and right (2) front hanger assemblies to outside surface of loader mountings using 14MM x 50MM cap screws (4) and 9/16" lock washers (6).

NOTE: Leave attaching hardware loose on front hanger brackets to facilitate proper assembly.

2. Remove drawbar from hitch assembly. Remove two rear and lower front 14MM x 35MM cap screws from each side of tractor rear hitch assembly. Remove tractor hitch assembly.

3. Install rear subframe mounting bracket (3) to tractor using 10 - 14MM x 45MM cap screws (5) and 9/16" lock washers (6). Torque 14MM hardware (5) securing rear subframe mounting brackets (3) to 110 ft./lbs. Reinstall tractor drawbar.

### INSTALLING SUBFRAME TO BACKHOE (Figure 3)

1. Install subframe assembly (9) to backhoe mainframe using 7/8" x 3" cap screws (13), 7/8" lock washers (14) and 7/8" nuts (14) in rear holes and 3/4" x 2 3/4" cap screws (12) and 3/4" lock nuts (11) in front holes.
2. Install support braces (16) onto subframe using 3/4" x 2-1/4" cap screws (12) and 3/4" lock nuts (11) in subframe (9) on backhoe mainframe. See Figure 2 for proper location depending on backhoe model being mounted.

NOTE: Double nut cap screw (items 11) after torquing first nut to 350 Ft. Lbs (475 N•M).

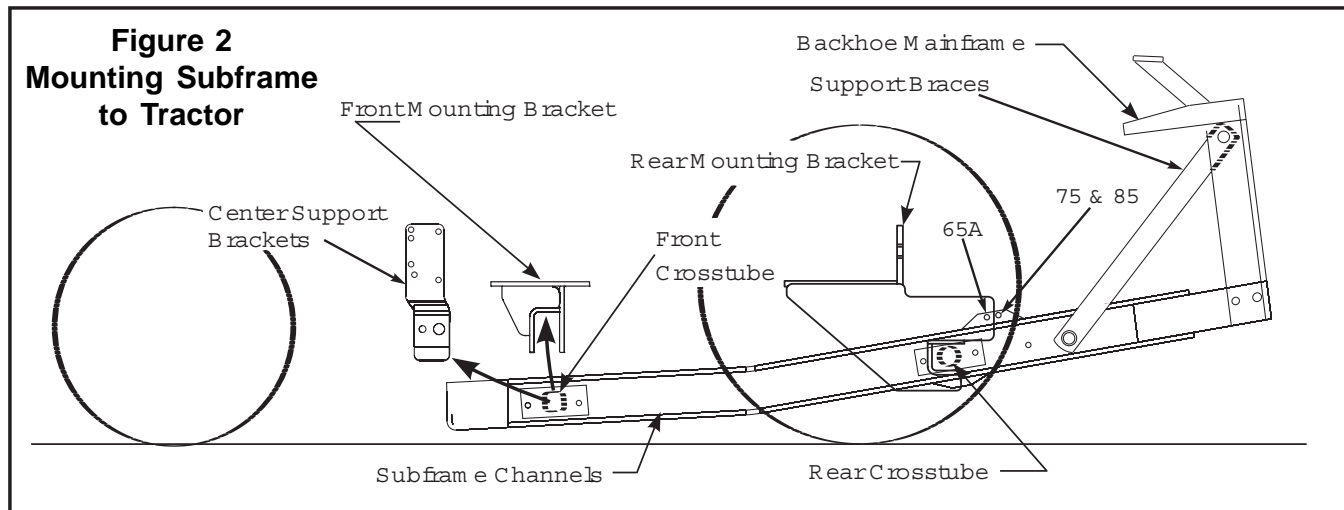

### PARTS LIST – SUBFRAME MOUNTING KIT

Item	Part No.	Description	Qty.
1	53160-1	FRONT HANGER ASSEMBLY, LEFT	1
2	53160-2	FRONT HANGER ASSEMBLY, RIGHT	1
3	51725	BRACKET ASSEMBLY, REAR	1
4	42672-58	MET HHCS, 14MM-1.50MM x 50MM	10
5	42672-60	MET HHCS, 14MM-1.50MM x 45MM	
6	41837-6	WASHER, LOCK, 9/16"	10
7	44892	PIN ASSEMBLY	20
8	44756-1	LINCH PIN	10
9	53168	SUBFRAME ASSEMBLY	1
10	41838-15	HHCS, 3/4" x 2.25"	2
11	47264-8	NUT, LOCK, 3/4" GR C	10
12	42969-4	HHCS, 3/4" x 2 3/4" GR8	4
13	41838-53	HHCS, 7/8" x 3"	2
14	41837-9	WASHER, LOCK 7/8"	2
15	41836-9	HEX NUT, 7/8" GR5	2
16	44836	MOUNT BAR	2
17	52106-2	PLUG, RECTANGULAR TUBE	4

## MOUNTING BACKHOE TO TRACTOR

1. Back tractor up to backhoe and center mount between the tractor rear tires. Position tractor so that the hydraulic system can be connected. Shut off tractor, set brake, and remove key.
2. Attach backhoe hydraulic system.
3. With the tractor PTO and transmission in neutral, start the engine and run at low idle. Hydraulic power is provided when the tractor is started.

**NOTE:** *Very little engine power is required to operate the hydraulic system in this mode. Should the engine pull down excessively, check the plumbing hookup for reversed lines or a control level stuck in an operating position.*

**NOTE:** *You will use the backhoe hydraulics to maneuver the backhoe into position. Use care in this procedure to avoid being trapped between tractor and backhoe or between backhoe parts.*

4. Using backhoe hydraulic controls, extend stabilizer cylinders and boom cylinder until rear crosstube is level with rear mounting bracket (3) and front of subframe is on ground (Figure 1).
5. Slowly back tractor until rear crosstube is seated in rear mounting bracket (3).
6. Retract boom cylinder and stabilizer cylinders so front of subframe swings up until front crosstube is seated in front mounting brackets (1&2) (See figure 2).
7. Secure front crosstube in place using pins (7) and linch pins (8).
8. Start tractor and cycle each cylinder a number of times to purge air. Put backhoe into transport position engage the swing lock, boom lock, and stabilizer lock (if equipped). Shut off tractor and check hydraulic oil level. Add tractor operators manual recommended fluid.

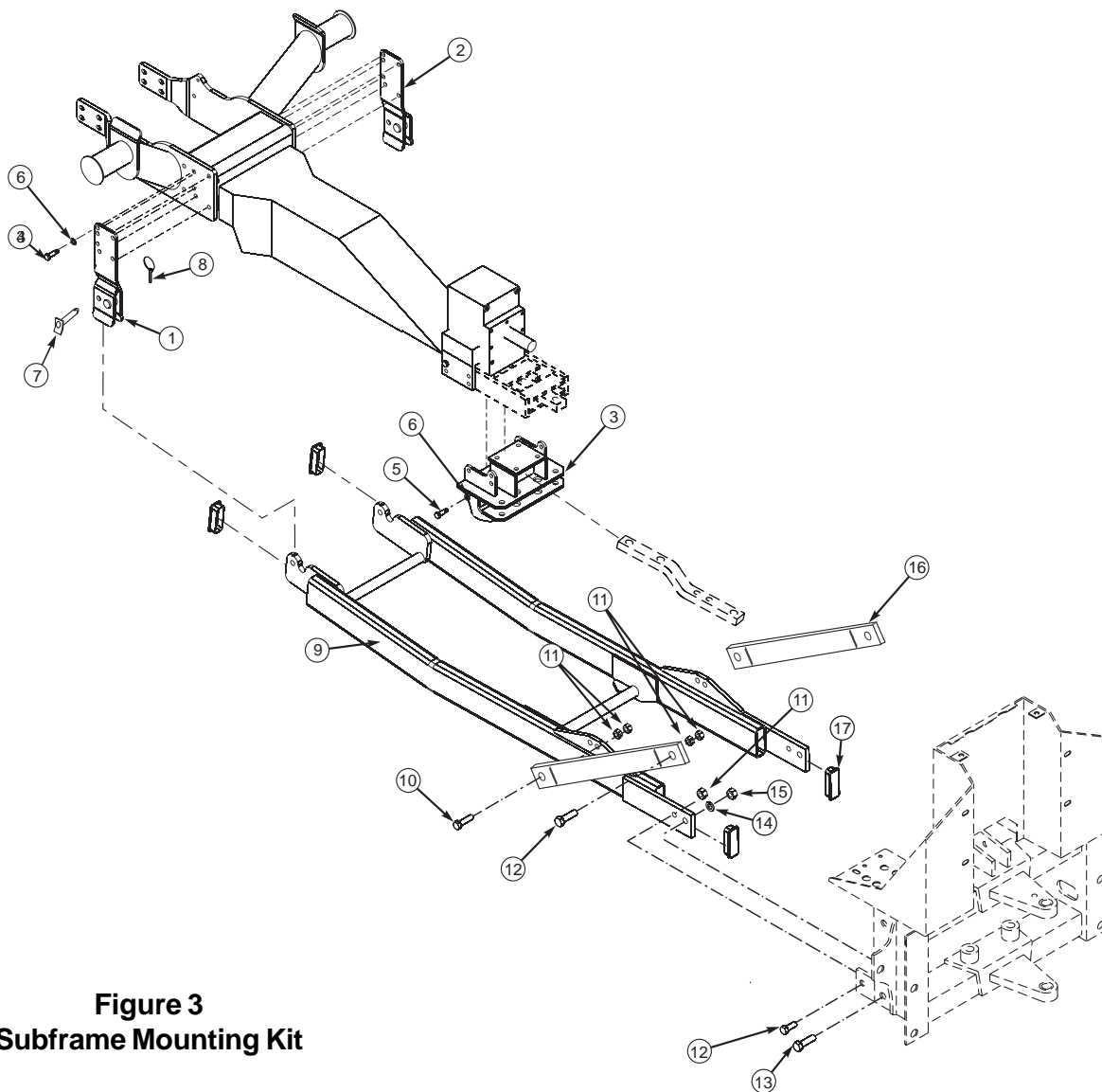





**Figure 3**  
**Subframe Mounting Kit**

## GENERAL TORQUE SPECIFICATIONS

USE THE FOLLOWING TORQUES WHEN SPECIAL TORQUES ARE NOT GIVEN

### Standard American and Metric Cap Screws

AMERICAN STANDARD CAP SCREWS									METRIC CAP SCREWS								
SAE Grade	5				8				Metric Class	8.8				10.9			
Typ. Head Markings									Typ. Head Markings								
Cap Screw	TORQUE				TORQUE				Cap Screw	TORQUE				TORQUE			
Size	FT-LBS		N-m		FT-LBS		N-m		Size	FT-LBS		N-m		FT-LBS		N-m	
Inches	MIN	MAX	MIN	MAX	MIN	MAX	MIN	MAX	Millimeters	MIN	MAX	MIN	MAX	MIN	MAX	MIN	MAX
1/4 - 20	6.25	7.25	8.5	10	8.25	9.5	11	13	M6 x 1.00	6	8	8	11	9	11	12	15
1/4 - 28	8	9	11	12	10.5	12	14	16	M8 x 1.25	16	20	21.5	27	23	27	31	36.5
5/16 - 18	14	15	19	20	18.5	20	25	27	M10 x 1.50	29	35	39	47	42	52	57	70
5/16 - 24	17.5	19	23	26	23	25	31	34	M12 x 1.75	52	62	70	84	75	91	102	123
3/8 - 16	26	28	35	38	35	37	47.5	50	M14 x 2.00	85	103	115	139	120	146	163	198
3/8 - 24	31	34	42	46	41	45	55.5	61	M16 x 2.50	130	158	176	214	176	216	238	293
7/16 - 14	41	45	55.5	61	55	60	74.5	81	M18 x 2.50	172	210	233	284	240	294	325	398
7/16 - 20	51	55	69	74.5	68	75	92	102	M20 x 2.50	247	301	335	408	343	426	465	577
1/2 - 13	65	72	88	97.5	86	96	116	130	M22 x 2.50	332	404	450	547	472	576	639	780
1/2 - 20	76	84	103	114	102	112	138	152	M24 x 3.00	423	517	573	700	599	732	812	992
9/16 - 12	95	105	129	142	127	140	172	190	M27 x 3.00	637	779	863	1055	898	1098	1217	1488
9/16 - 18	111	123	150	167	148	164	200	222	M30 x 3.00	872	1066	1181	1444	1224	1496	1658	2027
5/8 - 11	126	139	171	188	168	185	228	251	<p><b>NOTE:</b> These values apply to fasteners as received from supplier, dry or when lubricated with normal engine oil. They do not apply if special graphite or moly sulphide greases or other extreme lubricants are used.</p>								
5/8 - 18	152	168	206	228	203	224	275	304									
3/4 - 10	238	262	322	355	318	350	431	474									
3/4 - 16	274	305	371	409	365	402	495	544									
7/8 - 9	350	386	474	523	466	515	631	698									
7/8 - 14	407	448	551	607	543	597	736	809									
1 - 8	537	592	728	802	716	790	970	1070									
1 - 14	670	740	908	1003	894	987	1211	1337									

# INSTALLATION INSTRUCTIONS