

Keep With Operator's Manual
-----------------------------

## LOADER MOUNTING KIT 6212 LOADER

### John Deere 4050, 4055, 4240, 4250, 4255, 4320, 4430, 4440, 4450 Tractors

#### Tractor & Mounting Kit General Information

Mounting kit and loader can be installed using tools ordinarily available, including an overhead hoist and sling for initial loader installation, floor jack, standard and metric wrenches, and a torque wrench.

If tractor is equipped with front weights, weight and mounting bracket must be removed before installing loader mounting brackets. Refer to tractor operator's manual for removal of front weights.

Check front tire clearances once loader is installed and adjust tire track width as necessary.

Tractor front steering stops must be adjusted to provide a minimum of 3/4 " between front tire and any part of the loader on full left and right lock with front axle fully oscillated. Adjustment must be made with lift cylinders fully retracted. Refer to tractor operator's manual for steering stop adjustment.

Reference to left and right in these illustrations refer to position when seated in the operating position on tractor.

Shut off tractor, engage parking brakes, and remove key during installation of loader mounting kit.

#### Installing Loader Mounting Brackets (Figure 1)

**NOTE:** *Install all hardware loosely (unless noted otherwise) until loader mounting kit is completely assembled to facilitate assembly and proper alignment. Unless otherwise specified, tighten all hardware to torque values specified in general torque specification table when assembly is complete.*

If tractor is equipped with front weights, weight and mounting bracket must be removed before installing loader mounting brackets. Refer to tractor operator's manual for removal of front weights.

1. Install front bracket (1) to front of tractor using HHCS 3/4 x 2 (5) and 3/4 lock washers (6).
2. Place clevis over hole at top of left mid mounting bracket (2) and pin in place. Using an overhead hoist, raise left mid mounting (2) into position and secure to top hole in front bracket (1) using HHCS 5/8 x 2 (7), 5/8 lock washer (8) and 5/8 hex nut (9). Pivot mounting to align with holes on tractor frame. Fasten left mid mounting (2) to tractor frame using as many holes in mounting as possible with 5/8 x 2 carriage bolts (11) 5/8 lock washers (8) and 5/8 hex nut (9).
3. Place clevis over hole at top of right mid mounting bracket (3) and pin in place. Using an overhead hoist, raise right mid mounting (3) into position and secure to top hole in front bracket (1) using HHCS 5/8 x 2 (7), 5/8 lock washer (8) and 5/8 hex nut (9). Pivot mounting to align with holes on tractor frame. Fasten right mid mounting (2) to tractor frame using as many holes in mounting as possible with 5/8 x 2 carriage bolts (11) 5/8 lock washers (8) and 5/8 hex nut (9).
4. Using a floor jack, center crosstie assembly (4) under tractor beneath mid mounting assemblies. Raise crosstie assembly (4) and fasten to left and right mid mounting assemblies (2 & 3) using HHCS 5/8 x 2 (7), 5/8 flat washers (10), 5/8 lock washers (8) and 5/8 hex nuts (9).
5. Torque 5/8" hardware to 140 ft lbs (170 N•M) and 3/4" hardware to 262 ft lbs (322 N•M).

**Figure 1  
Mount Kit**

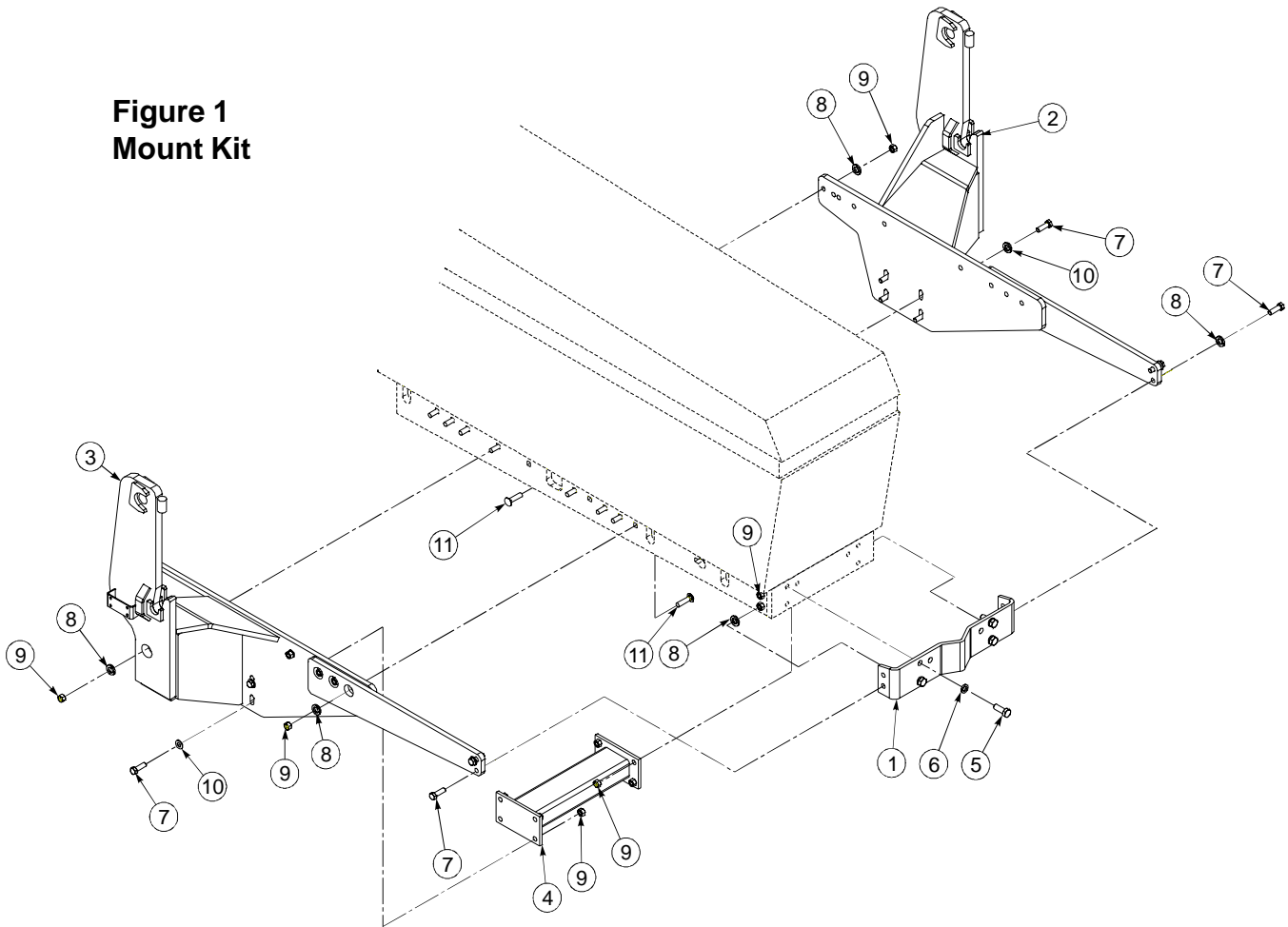

**PARTS LISTING - MOUNT KIT**

Part No.	Discription	Item Qty.
1	53269 FRONT BRACKET	1
2	53269 MID MOUNT ASSEMBLY, LEFT	1
3	53270 MID MOUNT ASSEMBLY, RIGHT	1
4	53185 CROSSTIE ASSEMBLY	1
5	41838-8 HHCS, 3/4-10 x 2.00" LG	4
6	41837-8 LOCK WASHER, 3/4"	4
7	41838-27 HHCS, 5/8-11 x 2.00" LG	12
8	41837-7 LOCK WASHER, 5/8"	28
9	41836-7 HEX NUT, 5/8-11	28
10	42502-32 FLAT WASHER, 5/8"	8
11	41839-7 CARRIAGE BOLT, 5/8-11 x 2.00"	16

**MOUNTING LOADER (Figures 2 - 7)**

**WARNING:** Loader must be supported before removing hardware securing loader to shipping pallet, or loader will tip over.

**WARNING:** To avoid injury during installation of quick attach loader, do not permit bystanders within ten feet of loader.

**WARNING:** To avoid injury during installation of quick attach loader, an overhead hoist must be used for initial mounting. Parking stands are not operational without bucket or heavy attachment mounted. (Bale spear or pallet fork alone do not provide enough weight.)

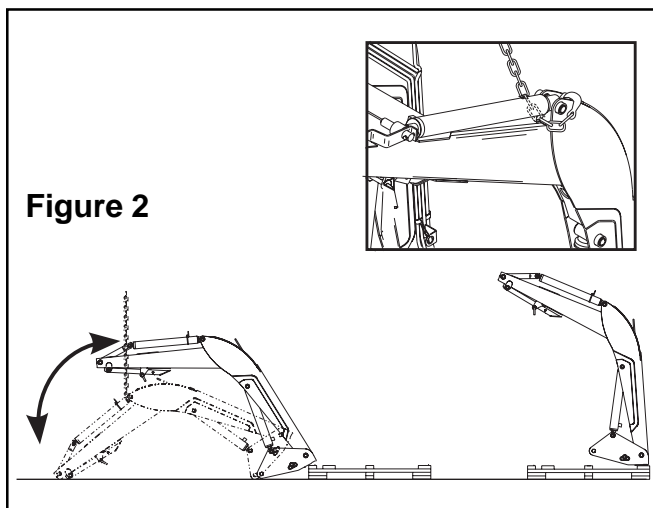
**Figure 2**

1. Using overhead hoist with nylon sling, lift loader at balance point (Figure 2). Remove hardware which secures loader to pallet. Remove linch pins and hitch pins from loader uprights (Figure 7).



**WARNING:** Loader uprights may rotate downward when loader is lifted from pallet.

Raise loader from shipping position and remove pallet, lower loader (scraps of cardboard may be used to protect paint).

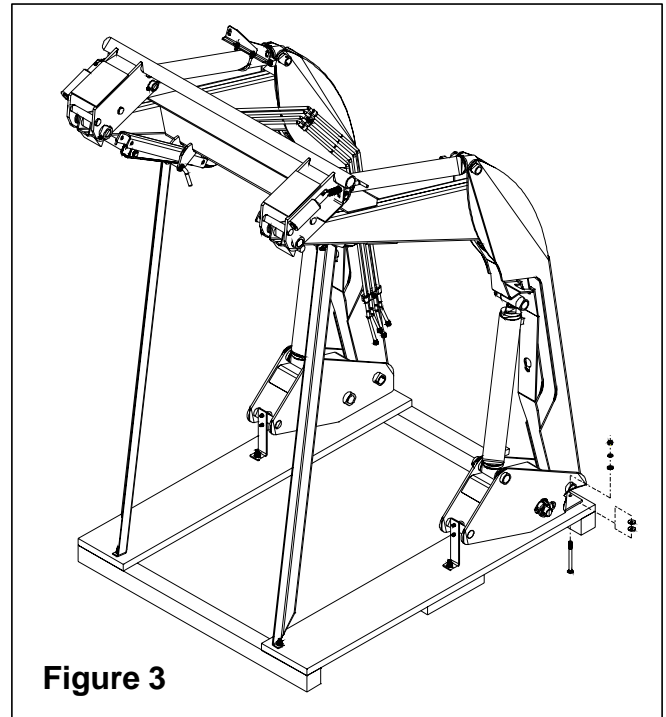
**Figure 3**

2. Secure a hoist strap around boom arm arms or secure with a chain hook, on underside of boom arm (see Figure 2). If using a strap, locate strap around boom arm in approximately same location as chain hook hole, similar to Figure 4. Slowly raise loader with overhead hoist until loader upright will clear tractor front tires (see Figure 4).

**NOTE:** Before mounting loader onto tractor with cab, rotate work lights, mounted on platform handrails, outward to prevent interference with loader uprights.

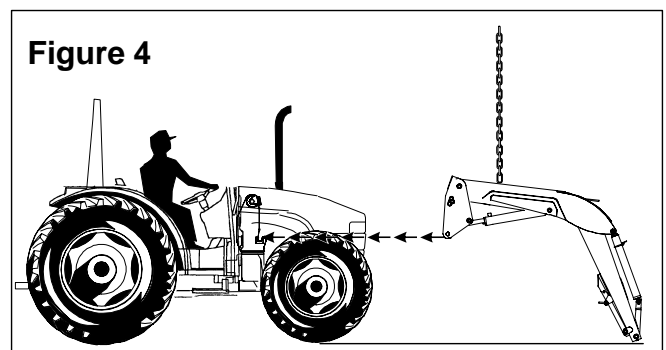
**Figure 4**

3. Drive tractor into loader until uprights of loader mounting brackets are within 12" to 18" of loader uprights. Shut off engine. Attach lift cylinder function hoses (color coded green and yellow) to corresponding tractor couplers.

**NOTE:** It is important to attach lift cylinder hoses (yellow and green spiral band coded) for loader to function properly. Do not connect boom oil line hoses for tilt cylinder control at this time. (Connect these after shipping brackets are removed from attachment pin hubs in instruction 12.)

4. Start engine. Retract lift cylinders fully and continue to activate control lever for approximately 10 seconds. Cycle cylinders several times to remove air. Extend lift cylinders 10" to 12" from the fully closed position to ensure loader upright pin will be first part of loader upright to make contact with mount vertical stop surface. Shut off engine, set parking brake and remove key

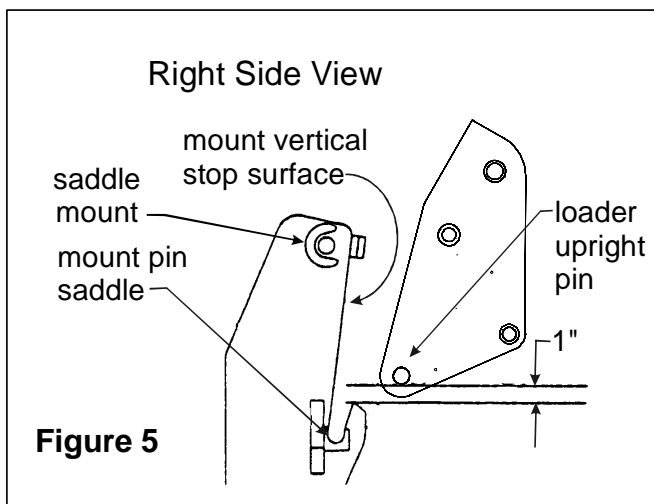

5. With overhead hoist, position loader upright pin to clear mount pin saddle by 1" (see Figure 5). Move tractor forward until both loader upright pins comes to rest against the flat vertical stop surface of both mounts. Lower loader with overhead hoist until both loader upright pins rest into mount pin saddles.

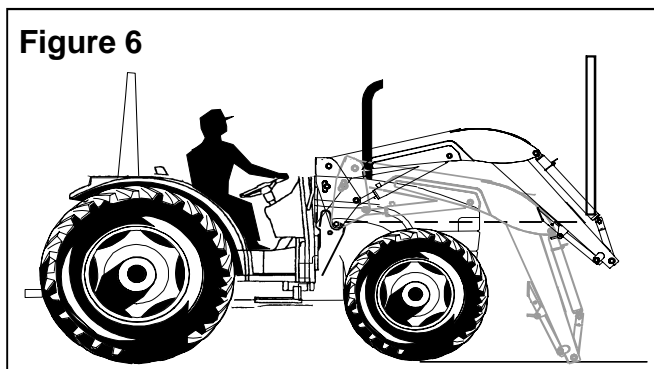

6. Remove hoist chain or strap from loader boom and secure to each bucket cylinder shipping brackets. Using overhead hoist raise front of loader to rotate loader upright into upper mount saddle (see Figure 6). Continue to rotate loader upright until upright has fully seated into back of mount saddle. Insert two 1-1/4 x 7" pins (I) and linch pins (H) which were removed from loader uprights in step 1. Remove hoist chain or strap from shipping brackets.

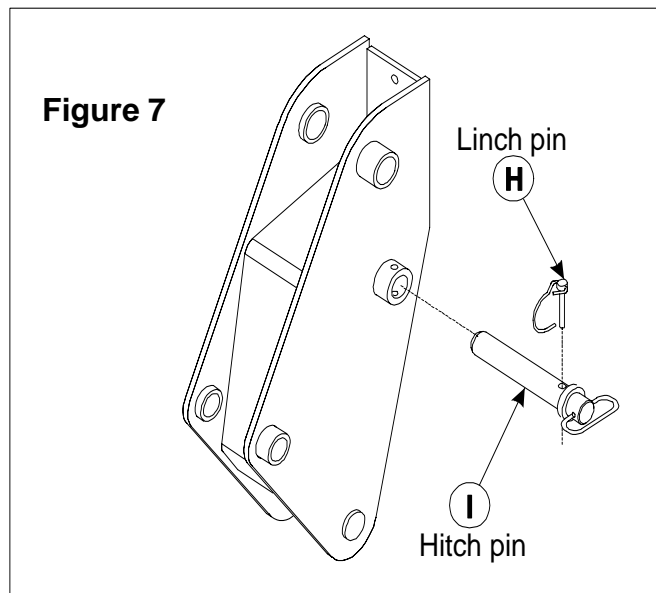

**NOTE:** In some cases a small amount of additional force may be required to insert the pins. If necessary, use a drift and hammer made of non-sparking material (a shot-filled mallet is recommended) to seat loader uprights into mount saddle.

7. Remove cap screws, lock nuts, pins, and shipping brackets. Discard shipping brackets, retain hardware for further use when installing bucket or attachment.
8. Attach tilt cylinder function hoses (color coded blue and red) to corresponding tractor couplers. For auxiliary valve, refer to instructions provided with kit for valve coupler function; for hose kit, refer to tractor operator's manual for remote coupler function. Cycle tilt cylinders several time to remove air.
9. Adjust front wheel tread settings or steering stops, if necessary, to provide a minimum 3/4" clearance between front tires and any part of loader with lift cylinders fully retracted and front axle fully oscillated. Be sure lift cylinders are fully retracted. Refer to page 1 under tractor and loader general information. Refer to tractor operator's manual for tread setting and steering stop adjustment procedures.

10. Lower Loader, Shut off engine, remove key and check tractor hydraulic oil level. Refill with oil specified in tractor operator's manual.

### INSTALLING BUCKET OR ATTACHMENT

Refer to loader operator's manual to install bucket or optional attachments.



**WARNING:** Always have a bucket attachment mounted to loader when it is removed from tractor. Pallet fork, bale spear, or similar attachments are too light to safely counterbalance loader boom arms when loader is dismantled from tractor.

### ATTACH LEVEL INDICATOR FOR BUCKET OR ATTACHMENT (Figure 8)

Refer to assembly instructions provided with bucket or optional attachment to attach level indicator rod.

**NOTE:** Attachment level setting varies for each loader attachment. It is important to make sure level indicator is adjusted to indicate level whenever a different attachment is mounted, or else level indicator will not indicate true level.



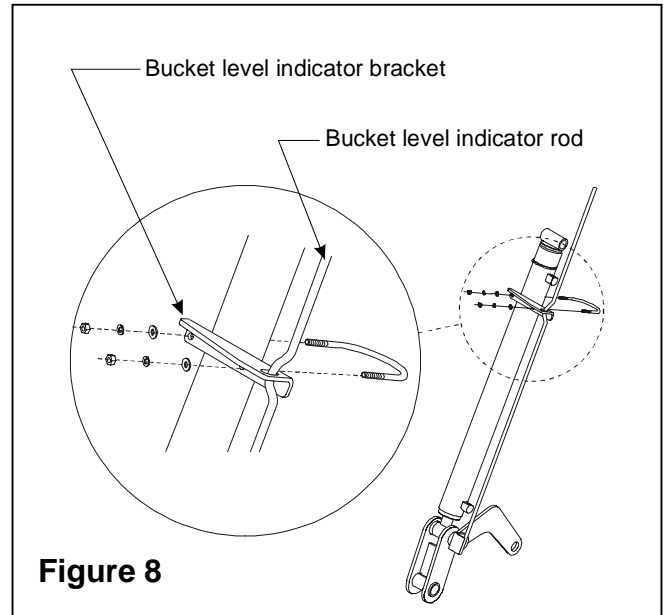



To adjust level indicator properly, locate tractor and loader attachment on a firm, level surface with attachment resting on level surface in level operating position. Loosen u-bolt that fastens level indicator bracket to right tilt cylinder and position it so it is centered on the offset in level indicator rod, then retighten u-bolt hardware.



**GENERAL TORQUE SPECIFICATIONS**

USE THE FOLLOWING TORQUES WHEN SPECIAL TORQUES ARE NOT GIVEN

**Standard American and Metric Cap Screws**

AMERICAN STANDARD CAP SCREWS										METRIC CAP SCREWS							
SAE Grade	5				8				Metric Class	8.8				10.9			
Typ. Head Markings									Typ. Head Markings	 				 			
Cap Screw	TORQUE				TORQUE				Cap Screw	TORQUE				TORQUE			
Size	FT-LBS		N·m		FT-LBS		N·m		Size	FT-LBS		N·m		FT-LBS		N·m	
Inches	MIN	MAX	MIN	MAX	MIN	MAX	MIN	MAX	Millimeters	MIN	MAX	MIN	MAX	MIN	MAX	MIN	MAX
1/4 - 20	6.25	7.25	8.5	10	8.25	9.5	11	13	M6 x 1.00	6	8	8	11	9	11	12	15
1/4 - 28	8	9	11	12	10.5	12	14	16	M8 x 1.25	16	20	21.5	27	23	27	31	36.5
5/16 - 18	14	15	19	20	18.5	20	25	27	M10 x 1.50	29	35	39	47	42	52	57	70
5/16 - 24	17.5	19	23	26	23	25	31	34	M12 x 1.75	52	62	70	84	75	91	102	123
3/8 - 16	26	28	35	38	35	37	47.5	50	M14 x 2.00	85	103	115	139	120	146	163	198
3/8 - 24	31	34	42	46	41	45	55.5	61	M16 x 2.50	130	158	176	214	176	216	238	293
7/16 - 14	41	45	55.5	61	55	60	74.5	81	M18 x 2.50	172	210	233	284	240	294	325	398
7/16 - 20	51	55	69	74.5	68	75	92	102	M20 x 2.50	247	301	335	408	343	426	465	577
1/2 - 13	65	72	88	97.5	86	96	116	130	M22 x 2.50	332	404	450	547	472	576	639	780
1/2 - 20	76	84	103	114	102	112	138	152	M24 x 3.00	423	517	573	700	599	732	812	992
9/16 - 12	95	105	129	142	127	140	172	190	M27 x 3.00	637	779	863	1055	898	1098	1217	1488
9/16 - 18	111	123	150	167	148	164	200	222	M30 x 3.00	872	1066	1181	1444	1224	1496	1658	2027
5/8 - 11	126	139	171	188	168	185	228	251	<p><b>NOTE:</b> These values apply to fasteners as received from supplier, dry or when lubricated with normal engine oil. They do not apply if special graphite or moly sulphide greases or other extreme lubricants are used.</p>								
5/8 - 18	152	168	206	228	203	224	275	304									
3/4 - 10	238	262	322	355	318	350	431	474									
3/4 - 16	274	305	371	409	365	402	495	544									
7/8 - 9	350	386	474	523	466	515	631	698									
7/8 - 14	407	448	551	607	543	597	736	809									
1 - 8	537	592	728	802	716	790	970	1070									
1 - 14	670	740	908	1003	894	987	1211	1337									

# INSTALLATION INSTRUCTIONS