

Keep With Operator's Manual

**LOADER MOUNTING KIT
5211 LOADER
MASSEY FERGUSON TRACTORS**

MODEL	2WD	FWA	CAB	ROPS
4243	X	X	X	X
4245	X	X	X	X
4253	X	X	X	X
4255	X	X	X	X
4345	X	X		X
4355	X	X		X

Mount kit can be installed using tools ordinarily available. Shut off engine and engage brakes during installation.

NOTE: Leave all attaching hardware loose until loader is completely assembled to facilitate assembly and proper alignment. Torque all hardware to specifications listed in loader operator's manual.

TRACTOR PREPARATION

1. Shut off engine, engage brakes, and remove key during installation of mounting kit.
2. If tractor is equipped with front weights, they should be removed. See tractor operators manual for correct procedure..
3. If tractor model 4243, 4245, 4253 or 4255 is equipped with toolbox, it will be necessary to relocate it where it will not interfere with loader.
4. To ease installation, if tractor is equipped with optional front fenders, they may be removed.
5. FWA Tractors- Remove factory installed front axle oscillation stops from each side of tractor and place three washers (15) between front axle casting and each factory oscillation stop as shown in figure 1A & 1B. Reattach oscillation stops with existing tractor hardware. This will limit tractor front axle oscillation, thus providing adequate clearance between front tire and loader.
6. Tractor steering stops must be adjusted to provide a minimum clearance of 3/4" between front tire and any part of loader on full left and right lock with front axle fully oscillated. Adjustment must be made with lift cylinders fully retracted. Refer to tractor operator's manual for steering stop adjustment.

INSTALLING LOADER MOUNTING BRACKETS (Figure 1A)

FOR MODEL 4243, 4245, 4253, 4255 TRACTORS

NOTE: Unless specified, leave all attaching hardware loose until mounting brackets are completely installed to facilitate assembly and proper alignment of mounting brackets.

1. FWA Tractors- Remove four 5/8" bolts from drive shaft hanger casting (located on underside of tractor) without removing casting. Remove two lower 5/8" bolts and round spacers from cab or platform support on right and left side of transmission casting. Retain 5/8" bolts from cab or platform support.

Attach crosstie (1) to underside of drive shaft hanger casting with four 5/8" x 2-1/4" cap screws (12) and lock washers (11). Attach crosstie between cab or platform support and transmission housing with 5/8" cap screws which were previously removed from tractor.

2WD Tractors - Remove four 5/8" bolts from cover plate (located on underside of tractor) without removing cover plate. Remove two lower 5/8" bolts and round spacers from cab or platform support on right and left side of transmission casting. Retain 5/8" bolts from cab or platform support.

Attach crosstie (1) to underside of cover plate with four 15/16" long spacers (8), four 5/8" x 2-1/4" cap screws (12) and lock washers (11). Attach crosstie between cab or platform support and transmission housing with 5/8" cap screws which were previously removed from tractor.

2. Loosen tractor fuel tank strap. Slide fuel tank outward approximately 1" to allow left midmount (4) installation. Note: Strap hardware is found directly behind tractor step.

INSTALLING LOADER MOUNTING BRACKETS (Figure 1A) (Continued)

3. Attach right and left midmountings (4 & 5) to rear hole pattern in front tractor casting using two 20mm x 55mm cap screws (6) and lock washers (7) per mounting.
4. Attach right and left midmountings (4 & 5) to crosstie (1) using four 5/8" x 1-3/4" cap screws (9) and 5/8" lock nuts (10) per mid mounting.
5. Slide tractor fuel tank back into position and secure with fuel tank strap and hardware.
6. Attach crossmember (2) to right and left mid mountings (4 & 5) using four 5/8" x 1-3/4" cap screws (9), 5/8" flat washers (14) and 5/8" lock nuts (10).
7. Tighten all hardware to torque specifications listed on page 8.

INSTALLING LOADER MOUNTING BRACKETS (Figure 1B)

FOR MODEL 4345 & 4355 TRACTORS

NOTE: Unless specified, leave all attaching hardware loose until mounting brackets are completely installed to facilitate assembly and proper alignment of mounting brackets.

1. FWA Tractors

Standard Hood - Remove four 5/8" bolts from drive shaft hanger casting (located on underside of tractor) without removing casting. Attach crosstie (1) to underside of drive shaft hanger casting with four 5/8" x 2-1/4" cap screws (12) and 5/8" lock washers (11). Attach crosstie (1) to lower holes on side of transmission casting using four 5/8" x 1-3/4" cap screws (9) and 5/8" lock washers (11).

"Hi Vis" Hood - Remove four 5/8" bolts from drive shaft hanger casting (located on underside of tractor) without removing casting. Remove lower 5/8" bolt and spacer securing battery housing support to right side of transmission casting and retain 5/8" bolt for reuse. Attach crosstie (1) to underside of drive shaft hanger casting with four 5/8" x 2-1/4" cap screws (12) and 5/8" lock washers (11). Attach crosstie (1) to lower holes on side of transmission casting using three 5/8" x 1-3/4" cap screws (9) and 5/8" lock washers (11). Add 5/8" lock washer to 5/8" bolt, which was previously removed from tractor, secure battery housing support and crosstie (1) to lower rear hole on right side of transmission casting.

NOTE: *Right crosstie lug is attached between battery housing support and transmission casting.*

2WD Tractors - Remove 5/8" bolts from cover plate (located on underside of tractor) without removing cover plate. Attach crosstie (1) to underside of transmission casting using two round spacers (8), two 5/8" x 2-1/4" cap screws (12) and 5/8" lock washers (11). Attach crosstie (1) to lower holes on side of transmission casting using four 5/8" x 1-3/4" cap screws (9) and 5/8" lock washers (11).

2. Attach right and left mid mountings (4 & 5) to rear hole pattern in front tractor casting using two 20mm x 55mm cap screws (6) and 20mm lock washers (7) per mounting.
3. Attach right and left mid mountings (4 & 5) to crosstie (1) using four 5/8" x 1-3/4" cap screws (9) and 5/8" lock nuts (10) per mid mounting.
4. Attach crossmember (2) to right and left mid mountings (4 & 5) using four 5/8" x 1-3/4" cap screws (13), 5/8" flat washers (14) and 5/8" lock nuts (10).
5. Tighten all hardware to torque specifications listed on page 8.

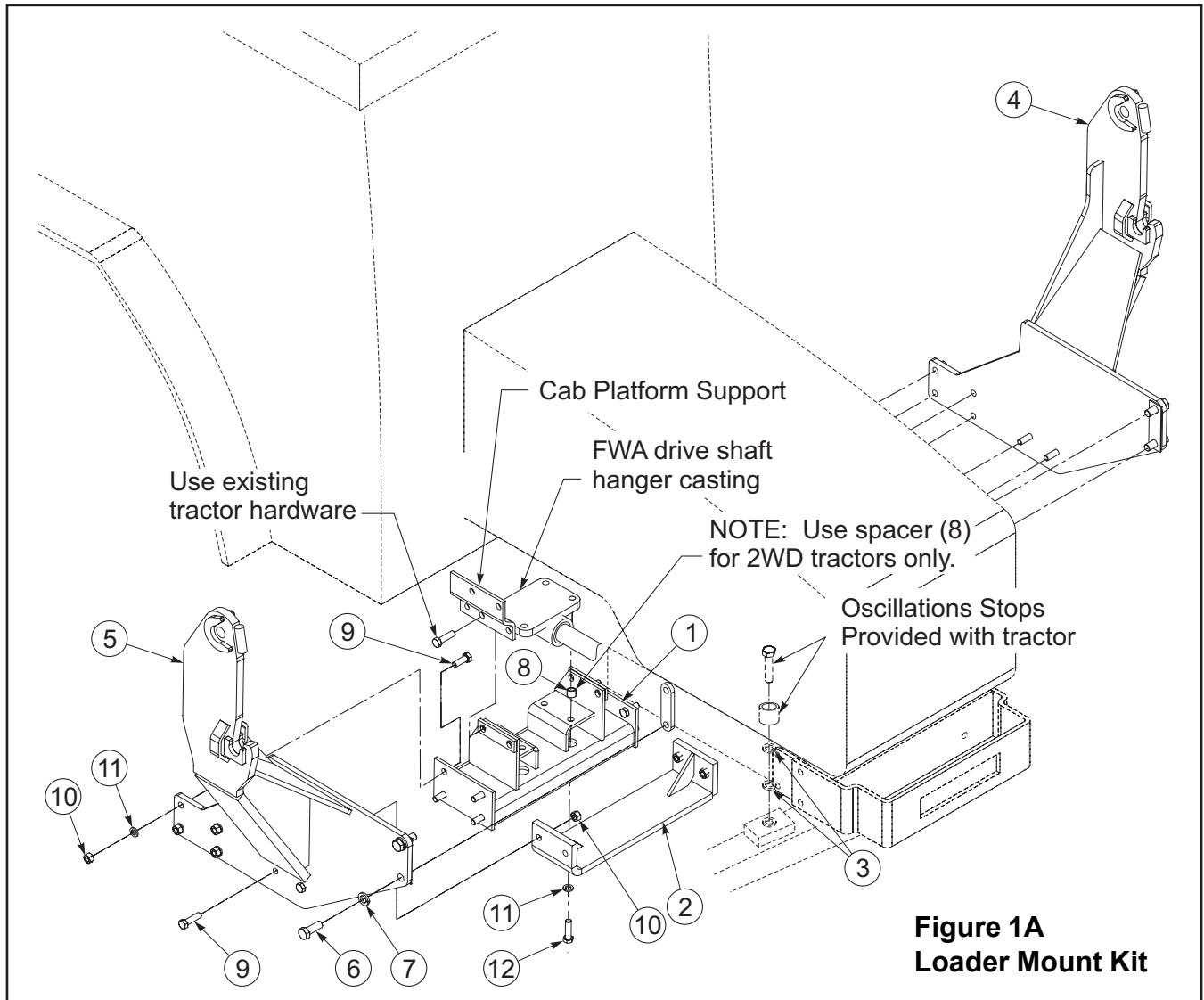

PARTS LIST – MOUNTING KIT - (For Tractor Models 4243, 4245, 4253, 4255)

Item	Part No.	Description	Qty.
1	49361	CROSSTIE, Assembly	1
2	53330	CROSSMEMBER	1
3	42502-30	WASHER (FWA Tractors Only)	6
4	53329	BRACKET, Mid Mounting, Left	1
5	53328	BRACKET, Mid Mounting, Right	1
6	42672-76	SCREW, Cap, 20mm-2.50 x 55mm, Gr. 8	4
7	48093-2	WASHER, Lock, 20mm	4
8	42787-4	SPACER, Tube (2WD Tractors Only)	4
9	41838-32	SCREW, Cap, 5/8-11 x 1-3/4	8
10	41840-7	NUT, Lock, 5/8-11	12
11	41837-7	WASHER, Lock, 5/8	4
12	41838-14	SCREW, Cap, 5/8-11 x 2-1/4, Gr. 5	4
13	41838-76	SCREW, Cap, 5/8-11 x 2-3/4	4
14	42502-12	WASHER, Flat, 5/8	4

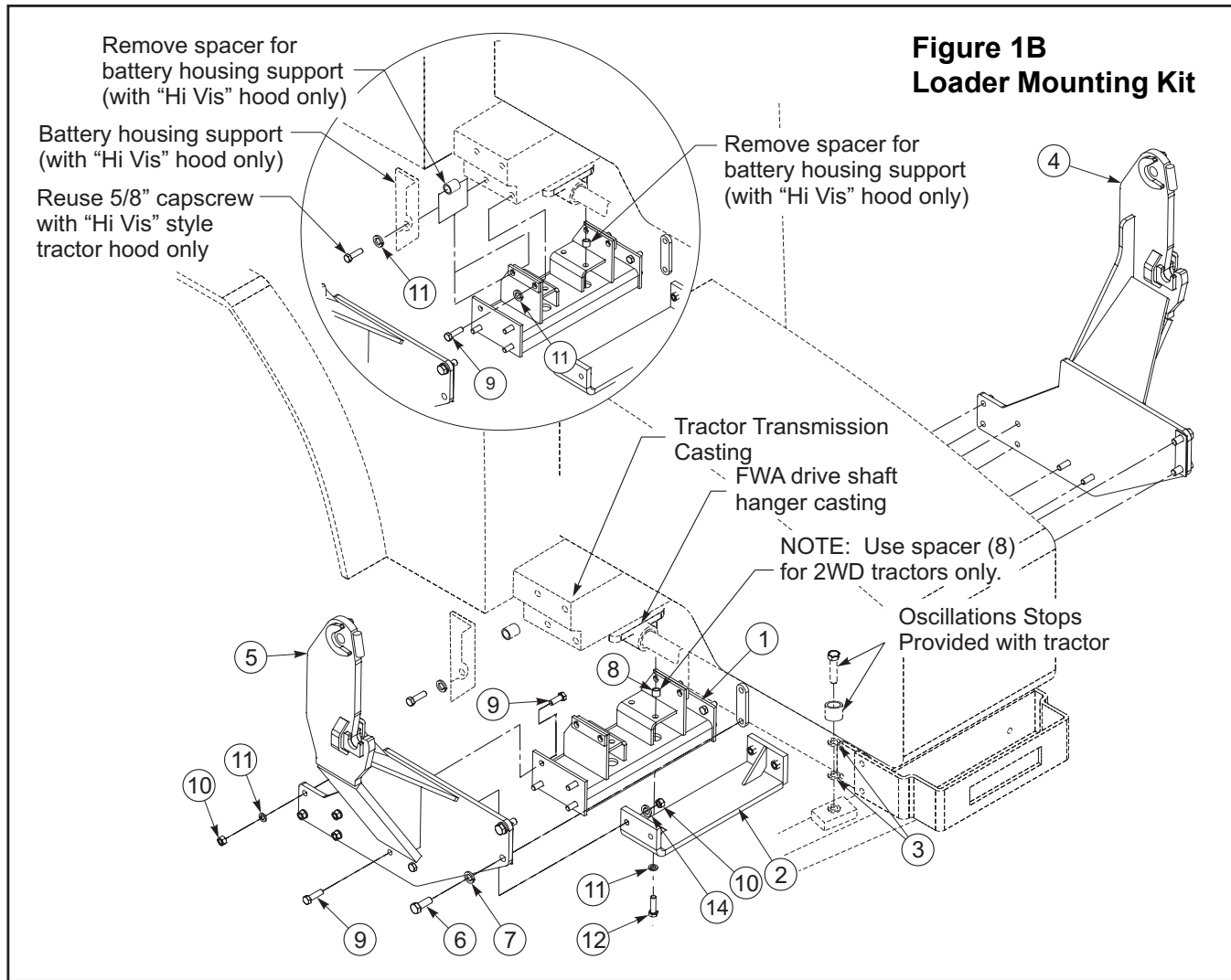

PARTS LIST – MOUNTING KIT - (For Tractor Models 4345 & 4355)

Item	Part No.	Description	Qty.
1	49361	CROSSTIE, Assembly	1
2	53330	CROSSMEMBER	1
3	42502-30	WASHER (FWA Tractors Only)	6
4	53329	BRACKET, Mid Mounting, Left	1
5	53328	BRACKET, Mid Mounting, Right	1
6	42672-76	SCREW, Cap, 20mm-2.50 x 55mm, Gr. 8	4
7	48093-2	WASHER, Lock, 20mm	4
8	42787-4	SPACER, Tube (2WD Tractors Only)	4
9	41838-32	SCREW, Cap, 5/8-11 x 1-3/4	11
10	41840-7	NUT, Lock, 5/8-11	12
11	41837-7	WASHER, Lock, 5/8	8
12	41838-14	SCREW, Cap, 5/8-11 x 2-1/4, Gr. 5	4
13	41838-76	SCREW, Cap, 5/8-11 x 2-3/4	4
14	42502-12	WASHER, Flat, 5/8	4

MOUNTING LOADER (Figures 2, 3, 4, 5, 6 & 7)

WARNING: Loader must be supported before removing hardware securing loader to shipping pallet, or loader will tip over.



WARNING: To avoid injury during installation of quick attach loader, do not permit bystanders within ten feet of loader.



WARNING: To avoid injury during installation of quick attach loader, an overhead hoist must be used for initial mounting. Parking stands are not operational without bucket or heavy attachment mounted. (Bale spear or pallet fork alone do not provide enough weight.)

1. Loop chain or sling under each bucket cylinder and hook on loader boom arm (see figure 2). Using overhead hoist to support loader, remove shipping angle braces (C) (figure 3) by temporarily removing linch pins (A) to remove angle braces, then reinstall linch pins which hold parking stands in position.

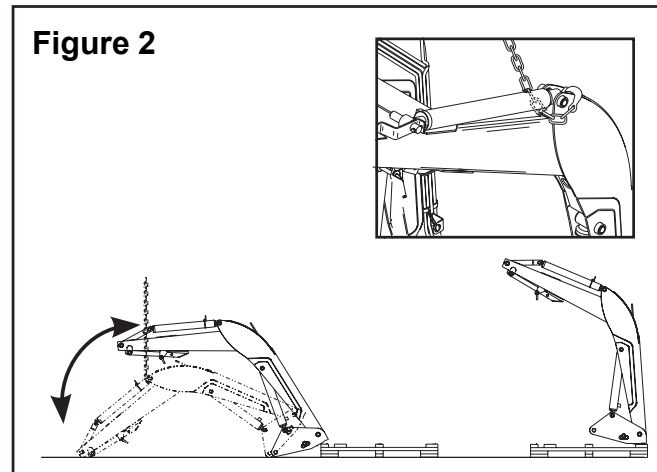

2. Remove nut and washers (B) from shipping braces (C) and discard braces and hardware.
3. Cut tie straps, remove linch pins (H) and hitch pins (I) (see figure 3) and keep with loader for securing uprights to mid-mounting brackets later.
4. Remove hardware (J) from shipping bracket (N). Discard brackets and hardware. Remove nuts and washers (P) from bolts securing loader to pallet. Raise loader.



WARNING: Loader uprights may rotate downward when loader is lifted from pallet.

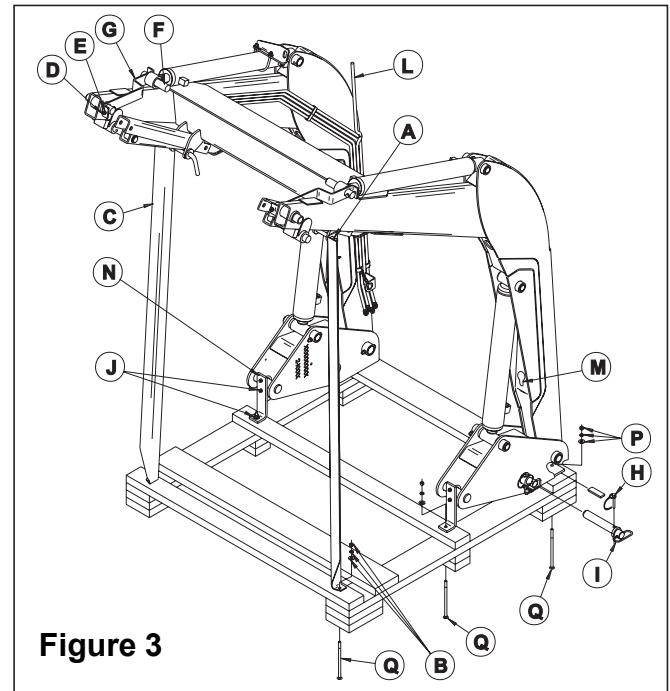

Figure 3

5. Remove all six carriage bolts (Q) from pallet (see figure 2) and position pallet at rear of loader to facilitate lowering (see figure 1). Lower loader from vertical shipping position to horizontal position (scraps of cardboard may be used to protect paint). Remove bucket level indicator rod (L) attached to oil lines for shipment.
6. Install hydraulic plumbing for loader to tractor using valve and plumbing or hose kit which is designed for use with this loader. Follow assembly instructions provided with hose kit to install hoses, sleeves, couplers, dust caps, and identification bands to loader boom oil lines.
7. Secure a hoist strap around the boom arm assembly or secure with a chain hook into hole (M) on underside of boom arm (see figure 2). If using a strap, the strap should be located around the boom arm near the same location as the chain hook hole, similar to figure 4. Slowly raise loader with overhead hoist until loader upright will clear tractor tires (see figure 4).

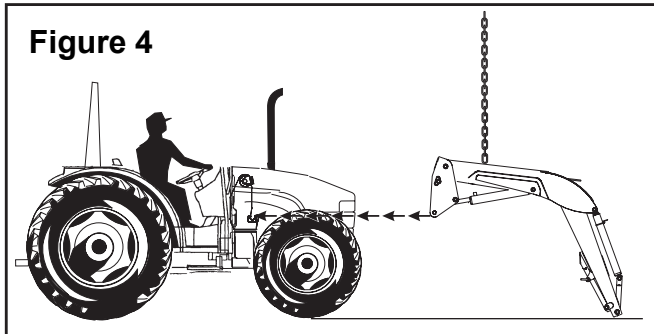

Figure 4

8. Drive tractor into loader until uprights of loader mounting brackets are within 12" to 18" loader uprights. Shut off engine. Attach lift cylinder function hoses (color coded green and yellow) to corresponding tractor couplers.

NOTE: It is important to attach lift cylinder hoses (yellow and green spiral band coded) for loader to function properly. Do not connect boom oil line hoses for tilt cylinder control at this time. (Connect these after shipping brackets are removed from attachment pin hubs instruction 12).

9. Start engine. Retract lift cylinders fully and continue to activate control lever for approximately 10 seconds. Cycle cylinders several times to remove air. Extend lift cylinders 10" to 12" from the fully closed position to ensure loader upright pin will be first part of loader upright to make contact with mount vertical stop surface. Shut off engine.

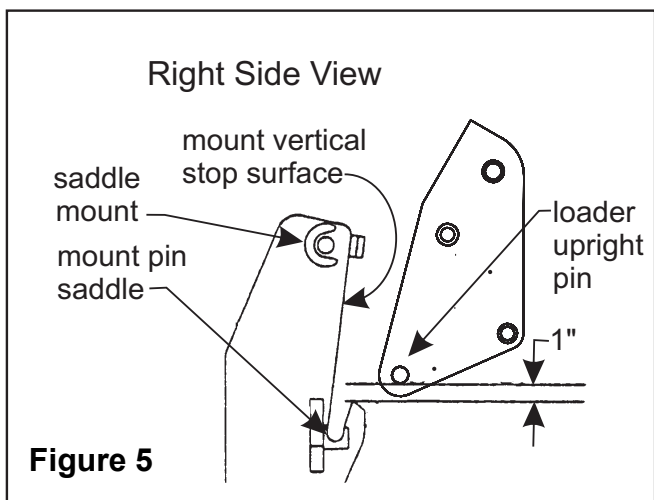

Figure 5

10. With overhead hoist, position loader upright pin to clear mount pin saddle by 1" (see figure 5). Move tractor forward until both loader upright pins come to rest against the flat vertical stop surface of both mounts. Lower loader with overhead hoist until both loader upright pins rest into mount pin saddles.

11. Remove hoist chain or strap from loader boom and secure to each bucket cylinder shipping brackets (G) (see figure 2). Using overhead hoist raise front of loader to rotate loader upright into upper mount saddle (see figure 6). Continue to rotate loader upright until upright has fully seated into back of mount saddle. Insert two 1-1/4 x 7" pins (I) and linch pins (H) which were removed from loader uprights in step 3. Remove hoist chain or strap from shipping brackets.

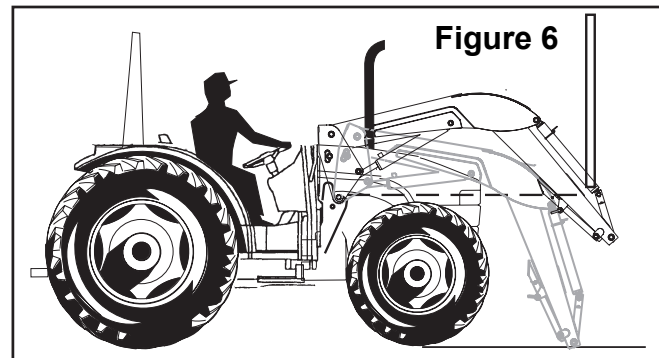
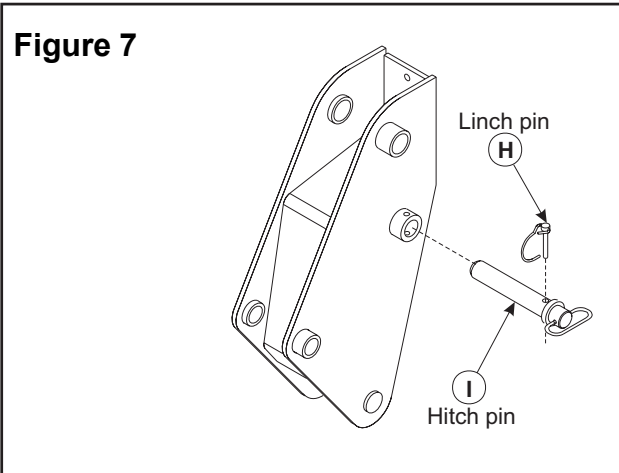

Figure 6

Figure 7



NOTE: In some cases a small amount of additional force may be required to insert the pins. If necessary, use a drift and hammer made of non-sparking material (a shot-filled mallet is recommended) to seat loader uprights into mount saddle.

12. Remove 3/8 cap screws (D), lock nuts (E), pins (F) and shipping brackets (G) (see figure 2). Discard shipping brackets, retain hardware for further use when installing bucket or attachment.
13. Attach tilt cylinder function hoses (color coded blue and red) to corresponding tractor couplers.
14. Start engine and fully extend and retract cylinders several times to purge air from hydraulic system. Add additional tractor hydraulic oil as specified in tractor operator's manual to bring level of hydraulic fluid up to full.
15. Adjust front wheel tread settings or steering stops, if necessary, to provide a minimum 3/4 inch clearance between front tires and any part of loader with lift cylinders fully retracted and front axle fully oscillated. Be sure lift cylinders are fully retracted. Refer to page 1 under tractor and loader general information. Refer to tractor operator's manual for tread setting and steering stop adjustment procedures.

INSTALLING BUCKET OR ATTACHMENT

Refer to loader operator's manual to install bucket or optional attachments.



WARNING: Always have a bucket attachment mounted to loader when loader is removed from tractor. Pallet fork, bale spear or similar attachments are too light to safely counterbalance loader boom arms when loader is dismantled from tractor.

ATTACH LEVEL INDICATOR FOR BUCKET OR ATTACHMENT (Figure 8)

Refer to assembly instructions provided with bucket or optional attachments to attach level indicator rod.

NOTE: Attachment level setting varies for each loader attachment. It is important to make sure level indicator is adjusted to indicate level whenever a different attachment is mounted, or else level indicator will not indicate true level.

To adjust level indicator properly, locate tractor and loader attachment on a firm level surface with attachment resting on level surface in operating position. Loosen u-bolt that fastens level indicator bracket to right tilt cylinder and position it so it is centered on the offset in level indicator rod, then retighten u-bolt hardware.

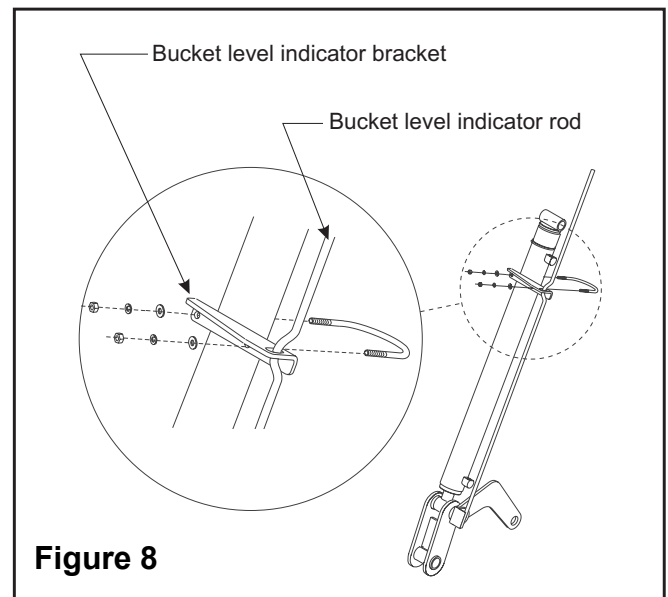





Figure 8

GENERAL TORQUE SPECIFICATIONS

USE THE FOLLOWING TORQUES WHEN SPECIAL TORQUES ARE NOT GIVEN

Standard American and Metric Cap Screws

AMERICAN STANDARD CAP SCREWS									METRIC CAP SCREWS								
SAE Grade	5				8				Metric Class	8.8				10.9			
Typ. Head Markings									Typ. Head Markings								
Cap Screw	TORQUE				TORQUE				Cap Screw	TORQUE				TORQUE			
Size	FT-LBS		N-m		FT-LBS		N-m		Size	FT-LBS		N-m		FT-LBS		N-m	
Inches	MIN	MAX	MIN	MAX	MIN	MAX	MIN	MAX	Millimeters	MIN	MAX	MIN	MAX	MIN	MAX	MIN	MAX
1/4 - 20	6.25	7.25	8.5	10	8.25	9.5	11	13	M6 x 1.00	6	8	8	11	9	11	12	15
1/4 - 28	8	9	11	12	10.5	12	14	16	M8 x 1.25	16	20	21.5	27	23	27	31	36.5
5/16 - 18	14	15	19	20	18.5	20	25	27	M10 x 1.50	29	35	39	47	42	52	57	70
5/16 - 24	17.5	19	23	26	23	25	31	34	M12 x 1.75	52	62	70	84	75	91	102	123
3/8 - 16	26	28	35	38	35	37	47.5	50	M14 x 2.00	85	103	115	139	120	146	163	198
3/8 - 24	31	34	42	46	41	45	55.5	61	M16 x 2.50	130	158	176	214	176	216	238	293
7/16 - 14	41	45	55.5	61	55	60	74.5	81	M18 x 2.50	172	210	233	284	240	294	325	398
7/16 - 20	51	55	69	74.5	68	75	92	102	M20 x 2.50	247	301	335	408	343	426	465	577
1/2 - 13	65	72	88	97.5	86	96	116	130	M22 x 2.50	332	404	450	547	472	576	639	780
1/2 - 20	76	84	103	114	102	112	138	152	M24 x 3.00	423	517	573	700	599	732	812	992
9/16 - 12	95	105	129	142	127	140	172	190	M27 x 3.00	637	779	863	1055	898	1098	1217	1488
9/16 - 18	111	123	150	167	148	164	200	222	M30 x 3.00	872	1066	1181	1444	1224	1496	1658	2027
5/8 - 11	126	139	171	188	168	185	228	251	<p>NOTE: These values apply to fasteners as received from supplier, dry or when lubricated with normal engine oil. They do not apply if special graphite or moly sulphide greases or other extreme lubricants are used.</p>								
5/8 - 18	152	168	206	228	203	224	275	304									
3/4 - 10	238	262	322	355	318	350	431	474									
3/4 - 16	274	305	371	409	365	402	495	544									
7/8 - 9	350	386	474	523	466	515	631	698									
7/8 - 14	407	448	551	607	543	597	736	809									
1 - 8	537	592	728	802	716	790	970	1070									
1 - 14	670	740	908	1003	894	987	1211	1337									

INSTALLATION INSTURCTIONS