

Keep With Operator's Manual

LOADER MOUNTING KIT 2408TL LOADER CASE IH & NEW HOLLAND CLASS III TRACTORS

CASE IH MODEL	NEW HOLLAND MODEL	2WD	FWA
D35, DX35	TC35, TC35A, TC35D, TC35DA	X	X
D40, DX40	TC40, TC40A, TC40D, TC40DA	X	X
D45, DX45	TC45, TC45A, TC45D, TC45DA	X	X

TRACTOR & MOUNTING KIT GENERAL INFORMATION

Mounting kit can be installed on tractor and loader using tools ordinarily available, including standard and metric wrenches and a torque wrench.

Valve and plumbing kit 2-7423 or hose kit to tractor loader control valve is required to plumb loader to tractor. It must be installed as part of initial loader mounting, but after loader mounting brackets have been installed. Refer to instructions later in this assembly manual and instructions contained in assembly manual provide with valve and plumbing kit.

This mounting kit is compatible with optional grille guard kit 2-7374. If grille guard is to be installed, it may be installed before or after installing loader mounting brackets or mounting loader.

Shut off engine and engage brakes during installation.

If tractor is equipped with factory cab the top front and bottom front cab mount bolts on both the left and right sides will need to be removed before installing loader mounts. The center front cab mount bolt on each side should not be removed. They will hold the cab in place while installing the loader mounts.

NOTE: Leave all attaching hardware loose until mounting brackets are completely assembled to facilitate assembly and proper alignment. Tighten all hardware to torques specified in general torque specifications table.

INSTALLING MOUNTING BRACKETS (Figure 1)

- Position 1/2 x 2 x 4" spacers (5), 1.12" long tube (not for tractors with cab) (17), 1.62" long tube (not for tractors with cab) (18), between left mid mounting bracket (1) at rear and left side of tractor transmission casting. Position 5/8 x 3 x 2.5" spacer (4) between left mid mounting bracket (1) at front and left side of tractor front frame. Fasten left mounting bracket (1) and spacers (5, 17, & 18) to left

side tractor transmission casting at rear using 16mm x 90mm cap screws (7) and 5/8" lock washers (16). Fasten left mid mounting bracket (1) and spacer (4) to tractor front frame using 5/8 x 3" cap screws (8), 5/8" flat washers (12), and 5/8" lock nuts (14).

- Repeat procedure for right side to fasten right mid mounting bracket (2) and spacers (4, 5, 17, & 18) to right side of tractor transmission casting and front frame.

NOTE: If tractor is equipped with New Holland loader valve, rear spacers (5) may not be required for right mid mounting bracket (2). A valve stand for older valves sandwiches to inside of right mid mounting bracket, instead of spacers (5) on right side.

- Fasten one rear reinforcement flat (3) to left mid mounting bracket (1) using 5/8 x 2-1/4" cap screws (9) and lock nuts (14). Fasten rear reinforcement flat to bracket which secures ROPS to tractor axle using 5/8 x 2-1/4" cap screws (9), flat washers (12), and lock nuts (14). Repeat procedure on right side of tractor to fasten remaining reinforcement flat (3) to right mid mounting bracket (2) and ROPS bracket on right side of axle.

NOTE: Instruction 4 applies only if tractor is equipped with New Holland loader valve. Refer to instructions provided with valve and plumbing kit or hose kit.

- Fasten valve bracket (6) to right mid mounting bracket (2) using 1/2 x 1-1/2" cap screws (10) and lock nuts (15). Use tube brackets provided with valve kit and attach oil lines to bracket using 1/4 x 1" cap screws (11) and lock nuts (16).
- Tighten all hardware to torques specified in general torque specification table.

Figure 1
Loader Mounting Kit

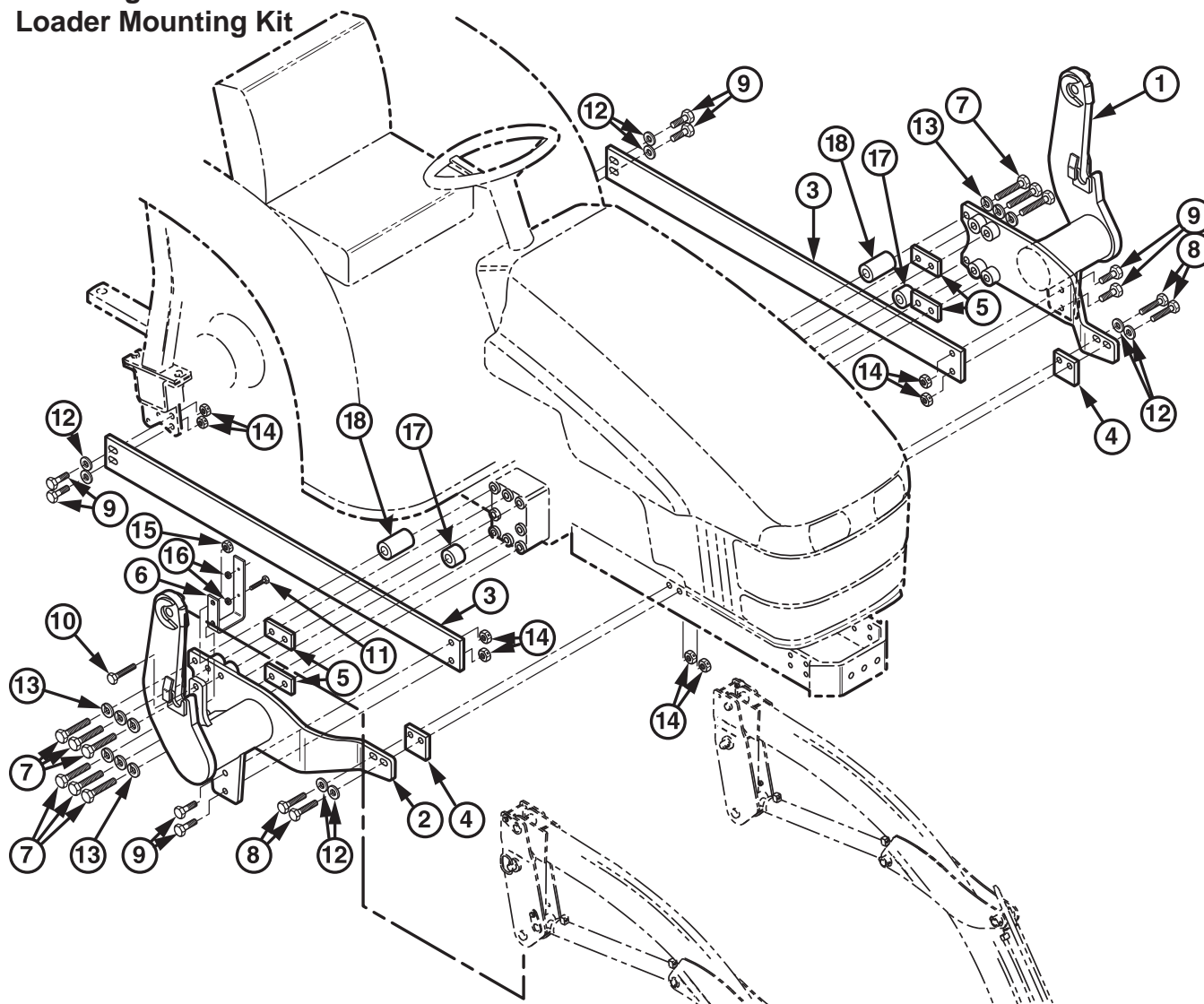

PARTS LIST - MOUNTING KIT

ITEM	PART NO.	DESCRIPTION	QTY.
1	54996	MOUNTING BRACKET, Mid, Left	1
2	54990	MOUNTING BRACKET, Mid, Right	1
3	52060	FLAT, Rear Reinforcement	2
4	54682	SPACER, 5/8 x 3 x 2.5	2
5	48796	SPACER, 1/2 x 2 x 4	4
6	49071	BRACKET, Valve (Use Only with New Holland Auxiliary Control Valve)	1
7	49040-10	SCREW, Cap, 16mm-2 x 90mm, Class 10.9	12
8	41838-86	SCREW, Cap, 5/8-11 x 3"	4
9	41838-14	SCREW, Cap, 5/8-11 x 2-1/4"	8
10	41838-33	SCREW, Cap, 1/2-13 x 1-1/2"	2
11	41838-62	SCREW, Cap, 1/4-20 x 1"	2
12	42502-12	WASHER, Flat, 5/8" SAE	8
13	41837-7	WASHER, Lock, 5/8"	12
14	41840-7	NUT, Lock, 5/8-11	12
15	41840-5	NUT, Lock, 1/2-13	2
16	41840-11	NUT, Lock, 1/4-20	2
17	49077-1	TUBE, 1.12 LG (NOT USED WITH CABS)	2
18	49077-2	TUBE, 1.62 LG (NOT USED WITH CABS)	2

MOUNTING LOADER (Figures 2, 3, 4, 5, 6, 7, & 8)



WARNING: Loader must be supported before removing hardware securing loader to shipping pallet or loader will tip over.



WARNING: To avoid injury during installation of loader, do not allow bystanders within ten feet of loader or attachment.



WARNING: To avoid injury during installation of loader, an overhead hoist must be used for initial mounting. Parking stands are not operational without bucket or heavy attachment mounted. (Bale spear or pallet fork alone do not provide enough weight.

1. Loop chain or sling under each tilt cylinder, around loader outer knee plate and hook to each outer knee plate (see figure 3). Put slight tension on overhead hoist to prevent loader from tipping.

2. Temporarily remove linch pins (B) and hitch pins (A) (see figure 3) and keep with loader for securing loader uprights to mid mounting brackets later.
3. Remove 3/8" lock nuts (E) and flat washers (D) which fasten loader uprights to pallet and can be found inside uprights near top end. Remove 3/8" lock nuts (E) which fasten shipping angle brackets (G) to pallet. Remove 5/16" lock nuts (H) from U-bolts (J) to remove shipping angle brackets (G) from loader. Discard shipping brackets and hardware. Raise loader off pallet and remove pallet with bucket (see figure 4a).



WARNING: Loader uprights may rotate downward when loader is lifted from pallet.

4. Lower loader from vertical shipping position to horizontal, positioning scraps of cardboard on floor under loader to protect loader paint (see figure 4b).

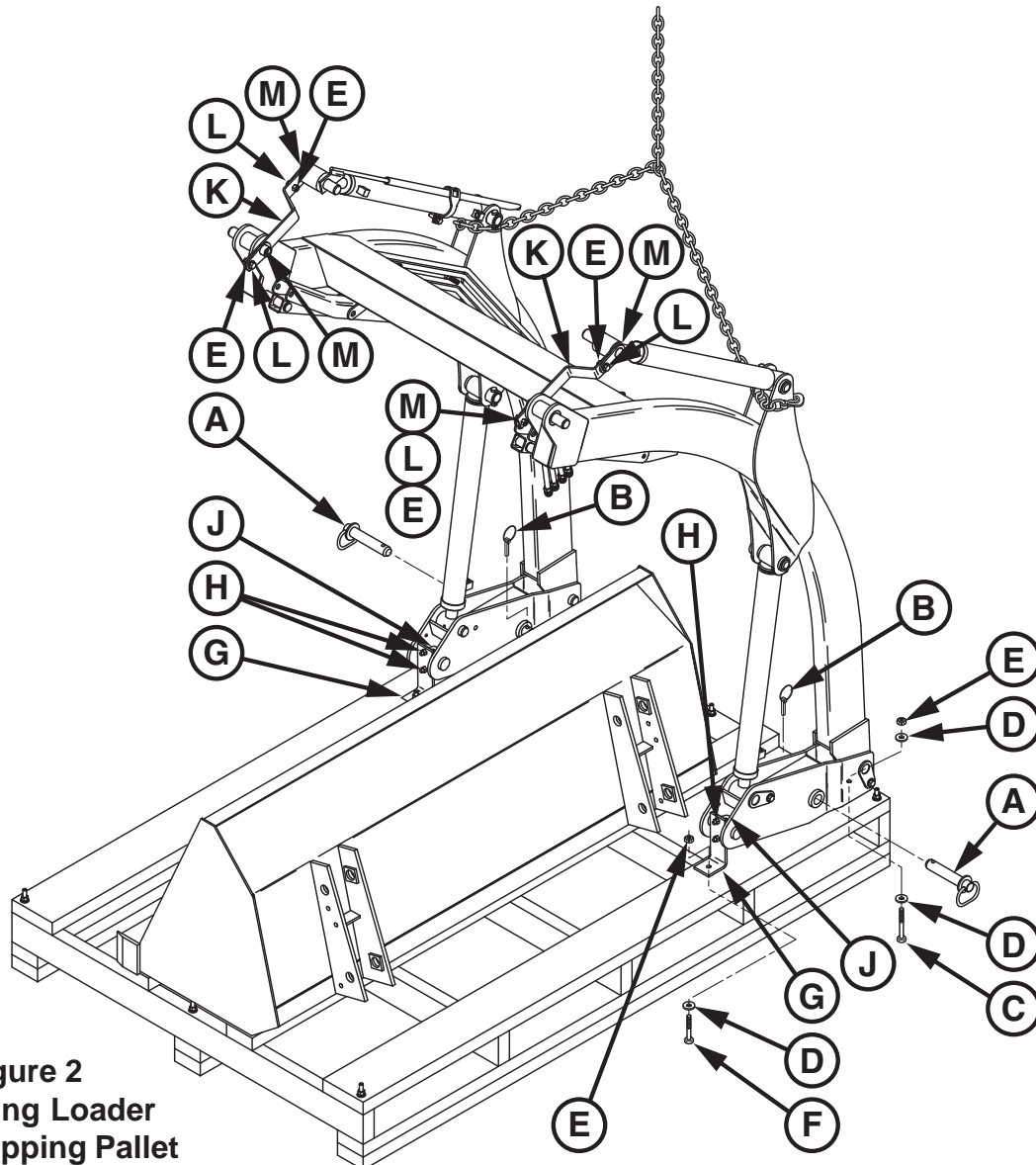

**Figure 2
Removing Loader
From Shipping Pallet**

Figure 3a
Remove Bucket
and Pallet

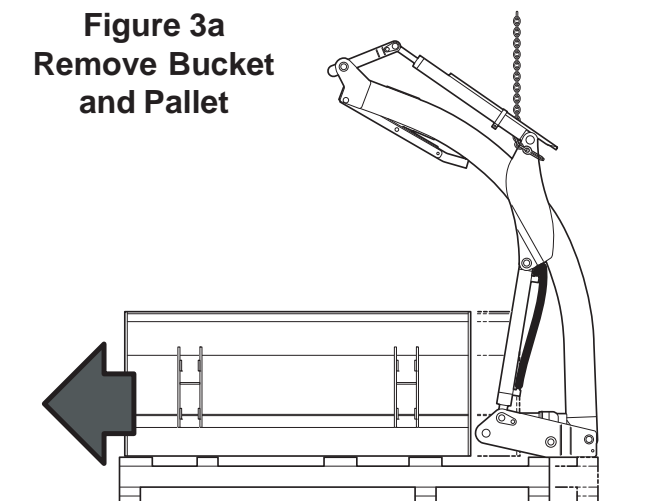
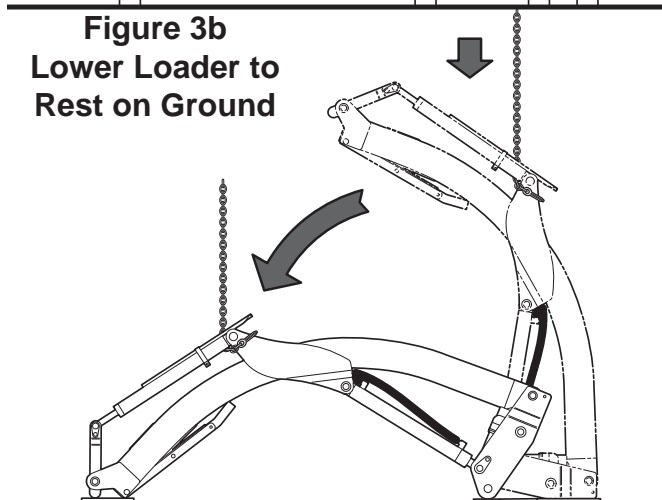

Figure 3b
Lower Loader to
Rest on Ground



5. Install hydraulic plumbing for loader to tractor using either kit for mod-mount valve or hose kit for rear of mid remotes.

6. Secure a hoist strap around loader upper boom arms similar to figure 4. Slowly raise loader with overhead hoist until loader upright will clear tires (see figure 4).

Figure 4

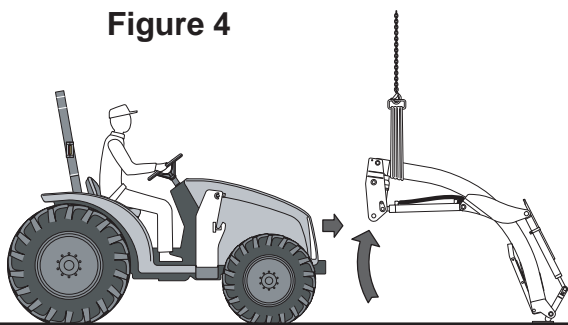

7. Drive tractor into loader until uprights of loader mounting brackets are within 12" or 18" of loader uprights. Shut off engine. Attach lift cylinder function hoses (color coded green and yellow) to corresponding tractor or valve couplers.

NOTE: It is important to attach lift cylinder hoses (coded with yellow and green bands) for loader to function properly. Do not connect boom oil line hoses for tilt cylinder control at this time. Connect these after shipping brackets are removed from attachment pin hubs in instruction 12.)

8. Start tractor engine. Retract lift cylinders fully and continue to activate control lever for approximately 10 seconds. Cycle cylinders several times to remove air. Extend lift cylinders four or five inches from the fully closed position to ensure loader upright pin will be first part of loader upright to make contact with stop surface of loader mounting brackets. Shut off engine and set brakes.

Figure 5

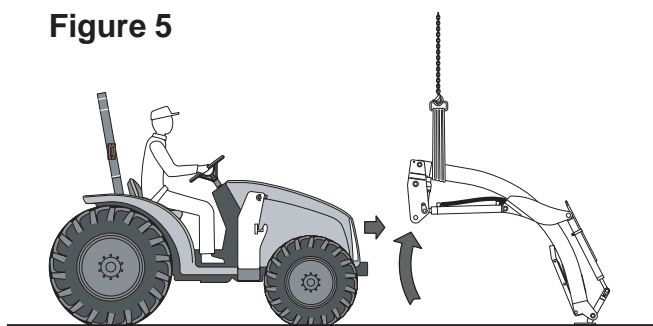

9. With overhead hoist, position loader upright pin to clear mount pin saddle by 1" (see figure 6). Start tractor engine and move tractor forward until both loader upright pins come to rest against flat vertical stop surface of both mounting brackets. Shut off engine and set brakes.

Figure 6

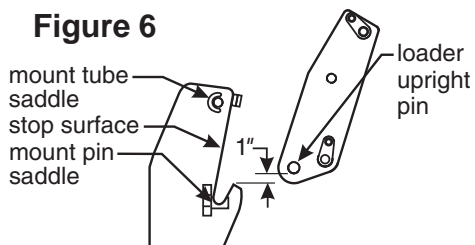

10. Lower loader with overhead hoist until both loader upright pins rest into mount pin saddles. Start tractor engine and retract lift cylinders, rotating loader uprights until uprights are fully seated into back of mount tube saddles (see figure 7).

Figure 7

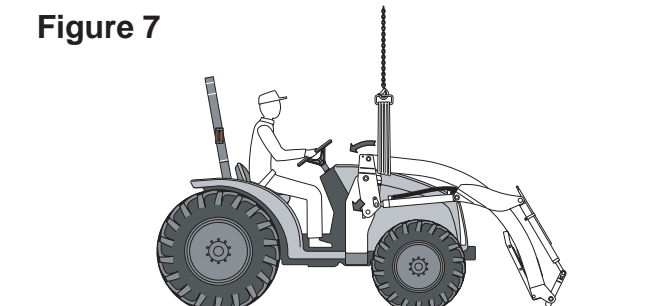

11. Shut off tractor engine and set parking brakes. Insert two 1" x 4-7/8" pins (A) and linch pins (B), which were removed from loader uprights in instruction 2. Remove hoist chain or strap from loader boom arms.

Figure 8

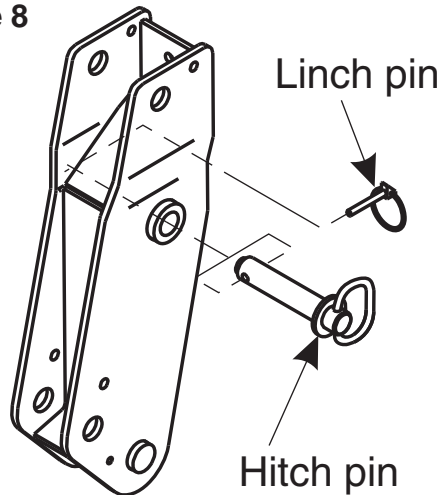

NOTE: In some cases a small amount of additional force may be required to insert pins. If necessary, use a drift and hammer made of non-sparking material (a shot-filled mallet is recommended) to seat loader uprights into mount tube saddles.

12. Remove 3/8" shoulder bolts (L) and lock nuts (E) to temporarily remove anti-rotation pins (M) to remove shipping brackets (K) (see figure 2). Discard shipping brackets (K), retaining anti-rotation pins and hardware for later reuse when installing bucket or attachment.
13. Attach tilt cylinder function hoses (color coded blue and red) to corresponding tractor or valve couplers.
14. Start engine and fully extend and retract cylinders several times to purge air from hydraulic system. Add additional tractor hydraulic fluid as specified in tractor operator's manual to bring level of hydraulic fluid up to full.
15. Adjust front wheel tread setting or steering stops, if necessary, to provide a minimum 3/4" clearance between front tires and any part of loader with lift cylinders fully retracted and front axle fully oscillated. Be sure lift cylinders are fully retracted. Refer to page 1, under preparing tractor. Refer to tractor operator's manual for tread setting and steering stop adjustment procedures.

INSTALLING BUCKET OR ATTACHMENT

Refer to loader operator's manual to install bucket or optional attachments. See instructions below for installing level rod with right tilt cylinder pin.



WARNING: Always have a bucket or heavy attachment attached to loader when it is removed from tractor. Pallet fork, bale spear, or similar attachments are too light to safely counterbalance loader boom arms when loader is dismantled from tractor.

ADJUSTING LEVEL INDICATOR FOR BUCKET OR ATTACHMENT (Figure 9)

Insert level rod into level indicator tube on right tilt cylinder. Pin level rod to rod end of right tilt cylinder by sandwiching level rod pivot angle between left side of cylinder cross tube and inside of attachment ear.

To adjust level indicator properly, locate tractor and loader attachment on a firm level surface with attachment resting on level surface in operating position. Loosen clamp bolt that fastens level indicator tube to right tilt cylinder and position it so end of level rod is at top end of tube.



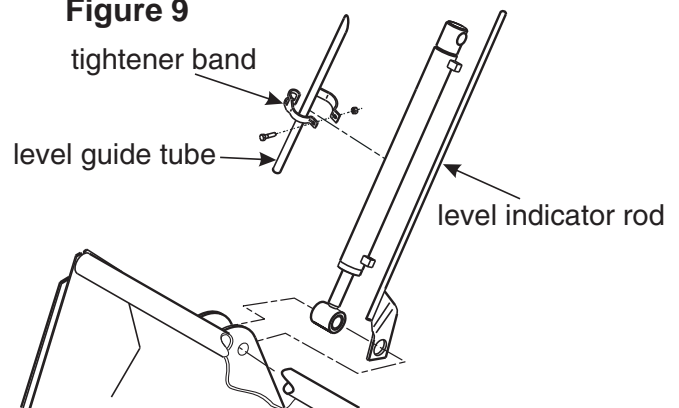

Figure 9



GENERAL TORQUE SPECIFICATIONS

USE THE FOLLOWING TORQUES WHEN SPECIAL TORQUES ARE NOT GIVEN

Standard American and Metric Cap Screws

AMERICAN STANDARD CAP SCREWS									METRIC CAP SCREWS								
SAE Grade	5				8				Metric Class	8.8				10.9			
Typ. Head Markings									Typ. Head Markings								
Cap Screw	TORQUE				TORQUE				Cap Screw	TORQUE				TORQUE			
Size	FT·LBS		N·m		FT·LBS		N·m		Size	FT·LBS		N·m		FT·LBS		N·m	
Inches	MIN	MAX	MIN	MAX	MIN	MAX	MIN	MAX	Millimeters	MIN	MAX	MIN	MAX	MIN	MAX	MIN	MAX
1/4 - 20	6.25	7.25	8.5	10	8.25	9.5	11	13	M6 x 1.00	6	8	8	11	9	11	12	15
1/4 - 28	8	9	11	12	10.5	12	14	16	M8 x 1.25	16	20	21.5	27	23	27	31	36.5
5/16 - 18	14	15	19	20	18.5	20	25	27	M10 x 1.50	29	35	39	47	42	52	57	70
5/16 - 24	17.5	19	23	26	23	25	31	34	M12 x 1.75	52	62	70	84	75	91	102	123
3/8 - 16	26	28	35	38	35	37	47.5	50	M14 x 2.00	85	103	115	139	120	146	163	198
3/8 - 24	31	34	42	46	41	45	55.5	61	M16 x 2.50	130	158	176	214	176	216	238	293
7/16 - 14	41	45	55.5	61	55	60	74.5	81	M18 x 2.50	172	210	233	284	240	294	325	398
7/16 - 20	51	55	69	74.5	68	75	92	102	M20 x 2.50	247	301	335	408	343	426	465	577
1/2 - 13	65	72	88	97.5	86	96	116	130	M22 x 2.50	332	404	450	547	472	576	639	780
1/2 - 20	76	84	103	114	102	112	138	152	M24 x 3.00	423	517	573	700	599	732	812	992
9/16 - 12	95	105	129	142	127	140	172	190	M27 x 3.00	637	779	863	1055	898	1098	1217	1488
9/16 - 18	111	123	150	167	148	164	200	222	M30 x 3.00	872	1066	1181	1444	1224	1496	1658	2027
5/8 - 11	126	139	171	188	168	185	228	251	<p>NOTE: These values apply to fasteners as received from supplier, dry or when lubricated with normal engine oil. They do not apply if special graphite or molysulphide greases or other extreme lubricants are used.</p>								
5/8 - 18	152	168	206	228	203	224	275	304									
3/4 - 10	238	262	322	355	318	350	431	474									
3/4 - 16	274	305	371	409	365	402	495	544									
7/8 - 9	350	386	474	523	466	515	631	698									
7/8 - 14	407	448	551	607	543	597	736	809									
1 - 8	537	592	728	802	716	790	970	1070									
1 - 14	670	740	908	1003	894	987	1211	1337									

INSTALLATION INSTRUCTIONS