



# TW15

ROTARY MOWER

Rev 01-17

Part No. 00792246P

## PART'S MANUAL



An Operator's Manual was shipped with the equipment in the Manual Canister. This Operator's Manual is an integral part of the safe operation of this machine and must be maintained with the unit at all times. **READ, UNDERSTAND, and FOLLOW** the Safety and Operation Instructions contained in this manual before operating the equipment. If the Operator's Manual is not with the equipment, contact your dealer or Servis-Rhino (800-446-5158) to obtain a Free copy before operating the equipment.



**RHINO®**  
1020 S. Sangamon Ave.  
Gibson City, IL 60936  
800-446-5158

Email: [parts@servis-rhino.com](mailto:parts@servis-rhino.com)

### ATENCIÓN!

LEA EL INSTRUCTIVO

Si No Lee Ingles, Pida Ayuda a Alguien  
Que Si Lo Lea Para Que le Traduzca las  
Medidas de Seguridad.



**A** MEMBER OF THE  
**ALAMO GROUP**  
ALWAYS ON THE CUTTING EDGE™

© 2016 Alamo Group Inc.

# TO THE OWNER/OPERATOR/DEALER

All implements with moving parts are potentially hazardous. There is no substitute for a cautious, safe-minded operator who recognizes the potential hazards and follows reasonable safety practices. The manufacturer has designed this implement to be used with all its safety equipment properly attached to minimize the chance of accidents.

**BEFORE YOU START!!** Read the safety messages on the implement and shown in your manual.  
Observe the rules of safety and common sense!



# DANGER

**FAILING TO FOLLOW SAFETY MESSAGES AND OPERATING INSTRUCTIONS CAN CAUSE SERIOUS BODILY INJURY OR EVEN DEATH TO OPERATOR AND OTHERS IN THE AREA.**

<p><b>1.</b></p> 	<p><b>2. NO RIDERS. NO CHILDREN OPERATORS.</b></p> 	<p><b>3. USE SAFETY SHOES, HARD HAT, SAFETY GLASSES, SEAT BELTS, &amp; ROPS.</b></p> 	<p><b>4. BLOCK UP SECURELY BEFORE WORKING UNDER.</b></p> 
<ol style="list-style-type: none"> <li>1. Study and understand Operator's Manuals, Safety Signs, and Instructional Decals for tractor &amp; flail mower to prevent misuse, abuse, &amp; accidents. Practice before operating mower in a confined area or near passersby.             <ul style="list-style-type: none"> <li>• Learn how to stop engine suddenly in an emergency. Be alert for passersby and especially children.</li> </ul> </li> <li>2. Allow no children on or near implement or tractor. Allow no riders on tractor or implement. Falling off can cause serious injury or death from being run over by tractor or mower or contact with Flail Mower Blades.</li> <li>3. Operate only with tractor having Roll-Over Protective Structure (ROPS) and with seatbelt fastened securely and snugly to prevent injury and possible death from falling off or tractor overturn. Personal Protective Equipment such as Hard Hat, Safety Glasses, Safety Shoes, and Ear Plugs are recommended.</li> <li>4. Block up or support raised machine and all lifted components securely before putting hands or feet under or working underneath any lifted component to prevent crushing injury or death from sudden dropping or inadvertent operation of controls. Make certain that area is clear before lowering or folding.</li> <li>5. Before transporting, put Lift Lever in detent or full-lift position. Install Transport Safety Devices securely on folding implements. Slow down when turning and on hillsides.             <ul style="list-style-type: none"> <li>• Install Restrictor in folding circuit to slow down lowering and unfolding if action is faster than is desirable.</li> </ul> </li> <li>6. Make certain that SMV sign, Warning Lights, and Reflectors are clearly visible. Follow local traffic codes.</li> <li>7. Never operate with Flail Mower or Folding Section raised if passersby, bystanders or traffic are in the area to reduce possibility of injury or death from objects thrown by Blades under Shields or implement structure.</li> <li>8. Before dismounting, secure flail mower in transport position or lower to ground.             <ul style="list-style-type: none"> <li>• Put tractor in park or set brake, disengage PTO, stop engine, remove key, and wait until noise of rotation has ceased to prevent entanglement in rotating parts which may cause injury or death.</li> <li>• Never mount or dismount a moving vehicle. Crushing from run over may cause injury or death.</li> </ul> </li> </ol>			
<p><b>5. TRANSPORT SAFELY, LOCK UP.</b></p> 	<p><b>6. USE SMV, LIGHTS, &amp; REFLECTORS.</b></p> 	<p><b>7. DO NOT OPERATE WITH MOWER OR WING RAISED.</b></p> 	<p><b>8. DO NOT MOUNT OR DISMOUNT WHILE MOVING.</b></p> 

002369

## WARRANTY INFORMATION:

Read and understand the complete Warranty Statement found in this Manual. Fill out the Warranty Registration Form in full and return it within 30 Days. Make certain the Serial Number of the Machine is recorded on the Warranty Card and on the Warranty Form that you retain. The use of "will-fit" parts will void your warranty and can cause catastrophic failure with possible injury or death.

# **PARTS SECTION**

# PARTS ORDERING GUIDE

The following instructions are offered to help eliminate needless delay and error in processing purchase orders for the equipment in this section.

1. The Parts Section is prepared in logical sequence and grouping of parts that belong to the basic machine featured in this manual. Part Numbers and Descriptions are given to help locate the parts and quantities required.
2. The Purchase Order must include the name and address of the person or organization ordering the parts, who should be charged, and if possible, the serial number of the machine for which the parts are ordered.
3. The Purchase Order must clearly list the quantity of each part, the complete and correct part number (be sure to include all periods), and the basic name of the part.
4. The Manufacturer reserves the right to substitute parts where applicable.
5. Some parts are unlisted items which are special production items not normally stocked and are subject to special handling. Request a quotation for such parts before sending a Purchase Order.
6. The Manufacturer reserves the right to change prices without prior notice.

**NOTE:** Please refer to The Safety Section in the front of this Manual for the proper Part Number when ordering Replacement Safety Decals.



For maximum safety and to guarantee optimum product reliability, always use genuine Servis-Rhino Parts. The use of inferior replacement parts may cause premature or catastrophic failure which could result in serious injury or death. Direct any questions regarding parts to:



**RHINO®**  
**1020 S. Sangamon Ave.**  
**Gibson City, IL 60936**  
**800-446-5158**  
**Email: [parts@servis-rhino.com](mailto:parts@servis-rhino.com)**

# PART NAME INDEX

A-FRAME ASSEMBLY.....	4
BLADE CARRIER ASSEMBLY.....	5
CANISTER ASSEMBLY.....	7
DECALS.....	8
DEFLECTOR ASSEMBLY.....	10
DRIVELINE ASSEMBLY - 00759318CSP CAT3 SLIP CLUTCH.....	12
DRIVELINE ASSEMBLY - 00789318SP CAT3 SHEAR BOLT.....	14
GEARBOX ASSEMBLY - 50074339 540RPM.....	16
GEARBOX ATTACHMENT.....	18
TAILWHEEL ASSEMBLY.....	20

## A-FRAME ASSEMBLY

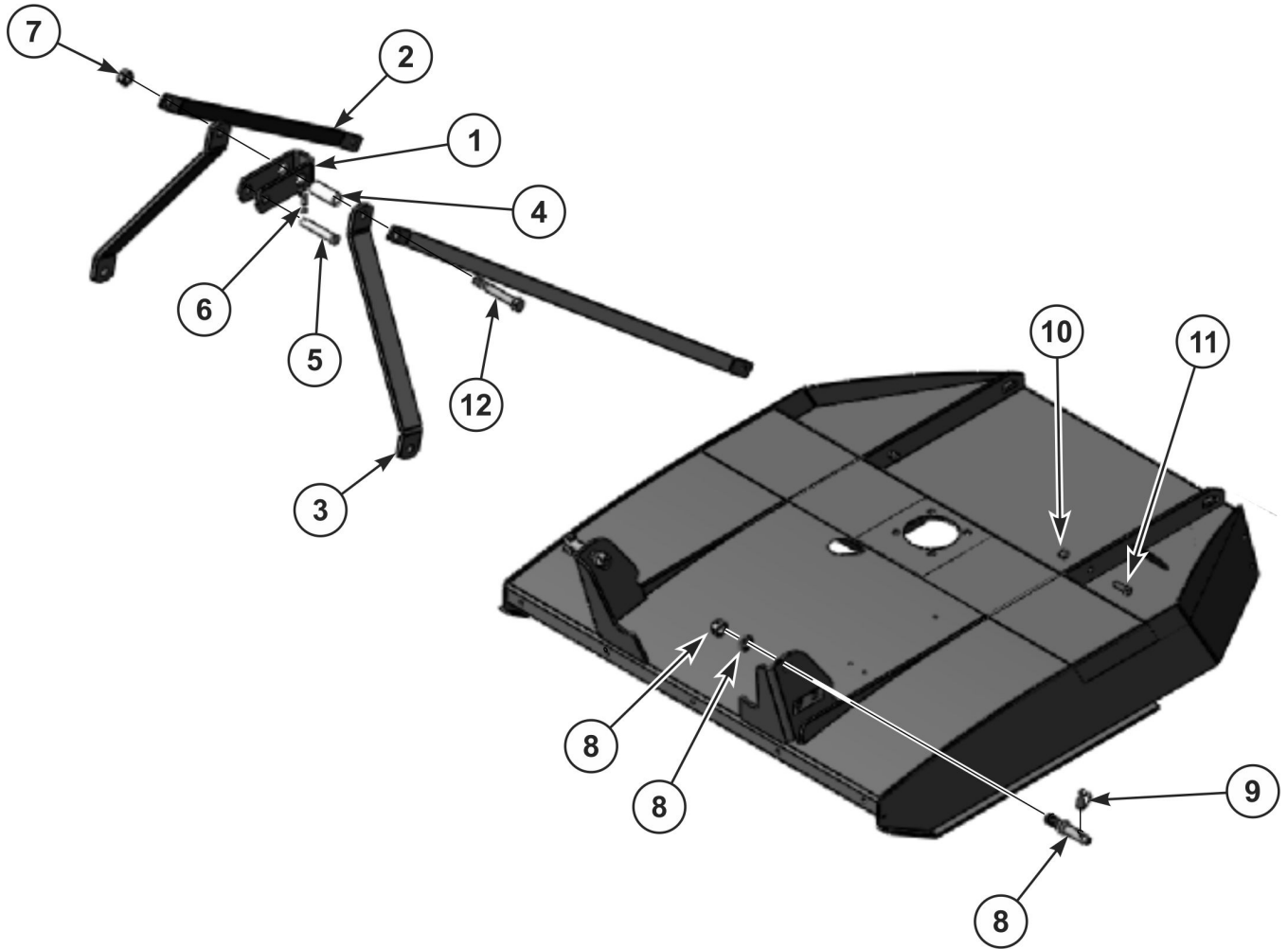

ITEM	PART NO.	QTY.	DESCRIPTION
1	00757949	1	TOP LINK
2	00766591	2	BRACE, REAR
3	00764839	2	A-FRAME BAR
4	00757953	1	BUSHING 1-1/4X7/32X3 A-FRAME
5	37107B12	1	CLEVIS PIN, TOP LINK - CAT. I
6	37107B13	1	PIN, HAIR CLIP
7	00037200	1	NUT,HEX TOPLOCK 3/4 NC GR.C PL
8	63765	2	LIFT PIN,CAT I
9	2196	2	CLIP (LYNCH PIN), 13/32 DIA.
10	00001800	2	LOCKNUT TLM 1/2 NC PLC
11	00749130	2	HHCS 1/2-13UNC 1-3/4 PL5
12	00748598	1	HEXB 3/4-10 UNC 5-1/2 PL 5

**BLANK INTENTIONALLY**

# BLADE CARRIER ASSEMBLY

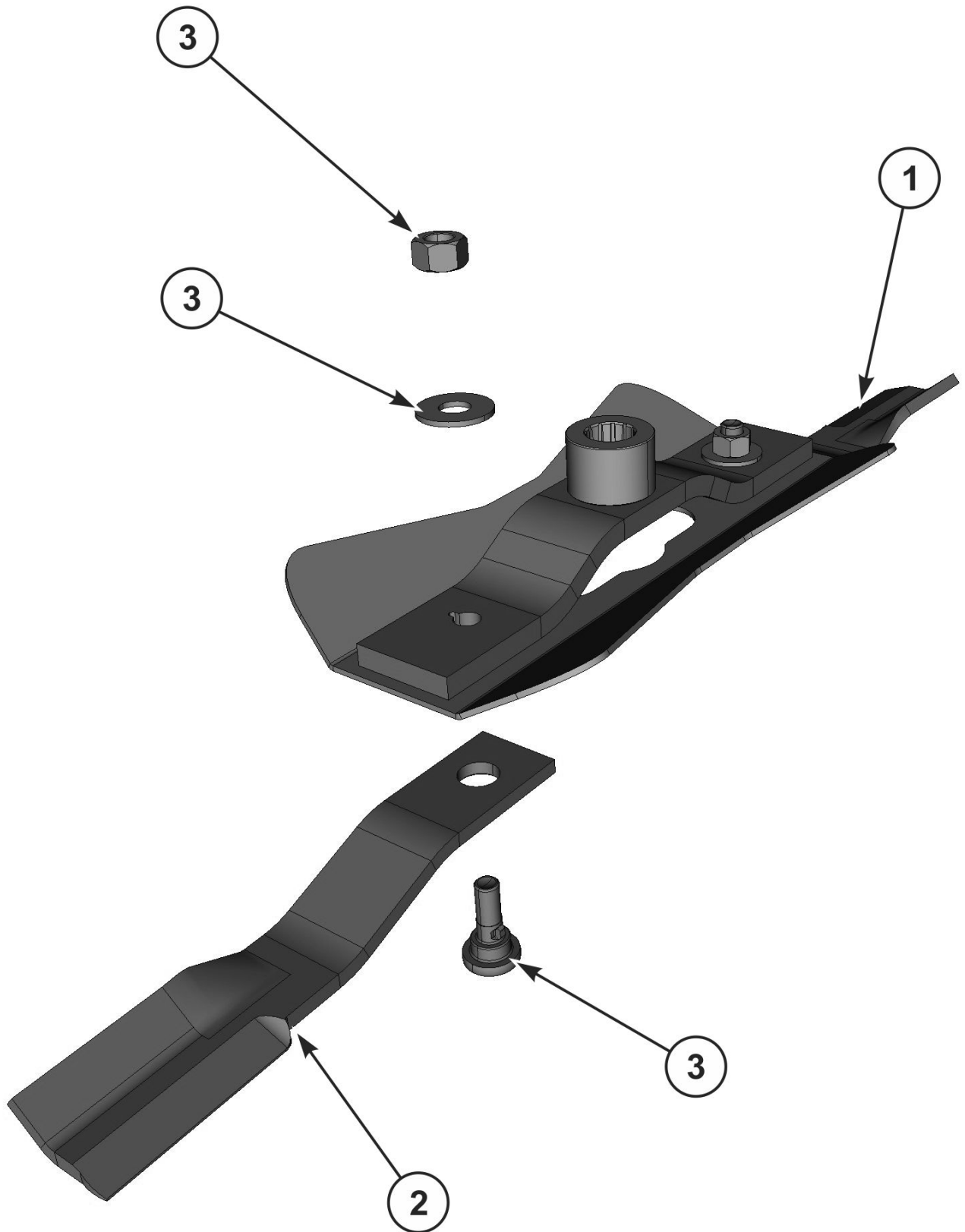



## BLADE CARRIER ASSEMBLY

Continued...

ITEM	PART NO.	QTY.	DESCRIPTION
1	00792191	1	WDMT, 15IN BLADE CARRIER
2	00781341	2	BLADE, FAN CCW, 22-1/2 CTR-TIP
3	00786548	1	BLADE BOLT KIT
	-----	2	NUT TOPLOCK 7/8 NF PLC
	-----	2	WASHER, 7/8" STRUCTURAL - PLAIN
	-----	2	BLADE BOLT 7/8 DIA X 3 LG

## CANISTER ASSEMBLY

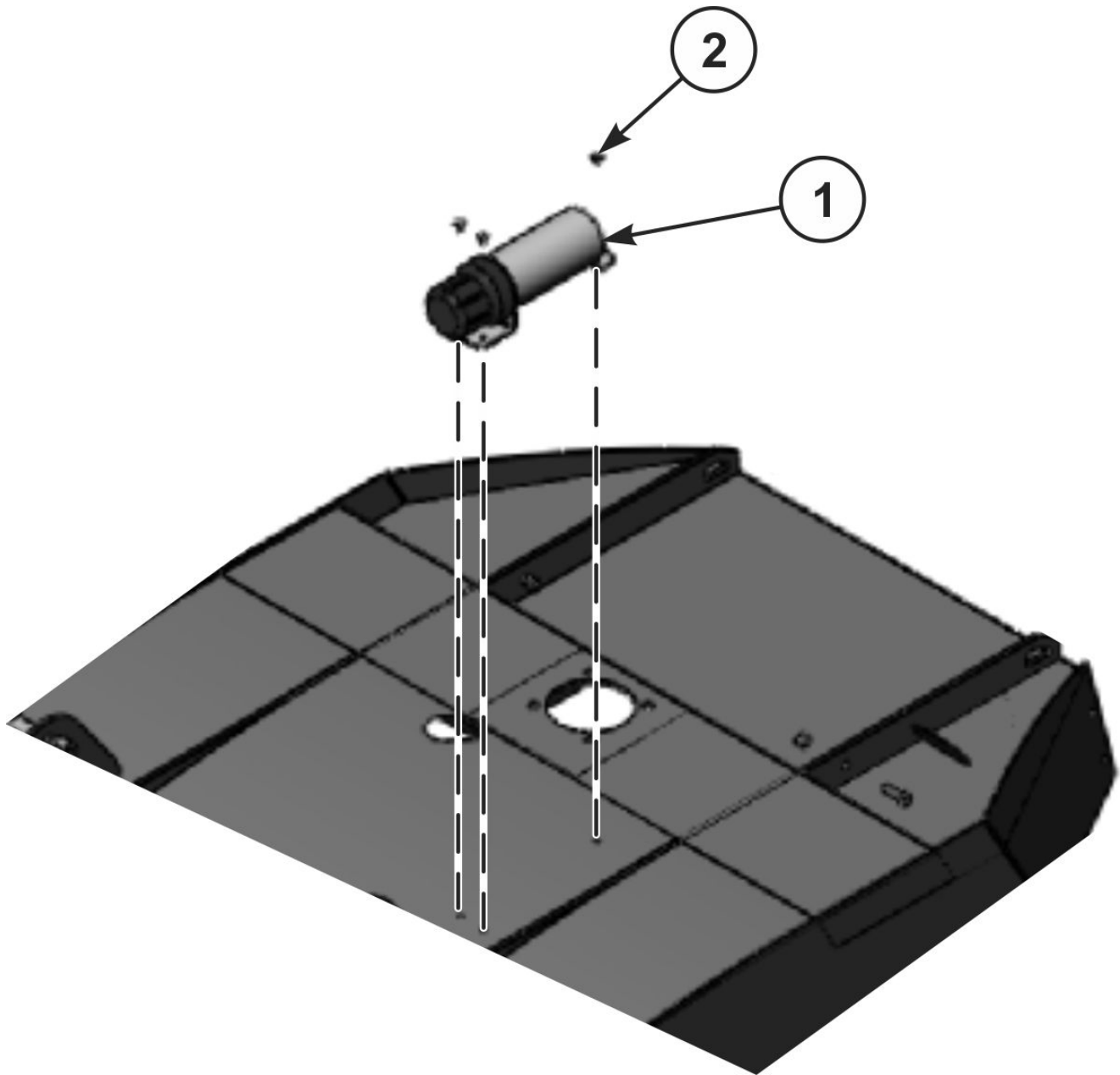

ITEM	PART NO.	QTY.	DESCRIPTION
1	00776031	1	CANISTER, PARTS MANUAL
2	00780878	3	RIVET, 3/16 POP X 15/32" G.R.

**BLANK INTENTIONALLY**

# DECALS

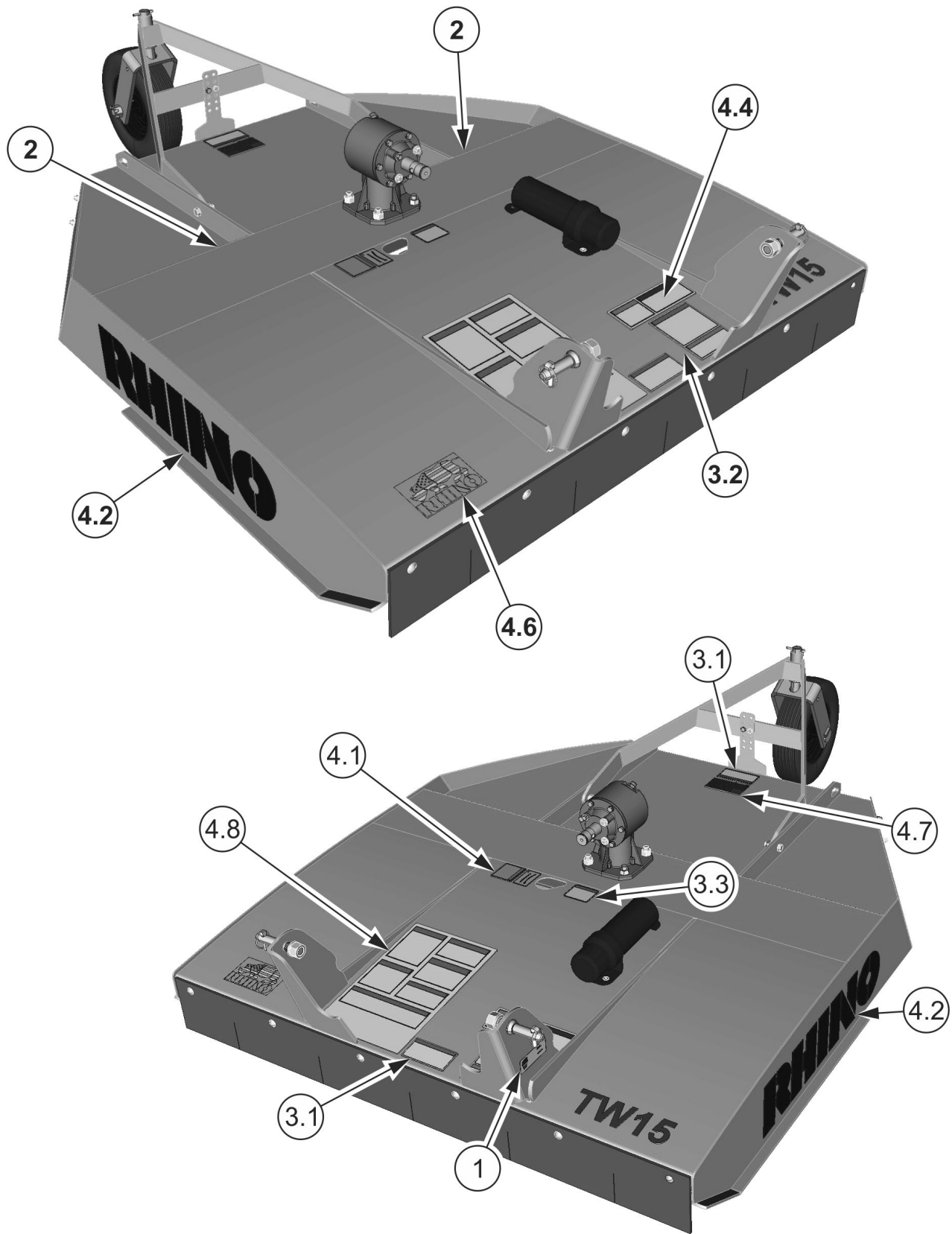

TW15

## DECALS

Continued...

ITEM	PART NO.	QTY.	DESCRIPTION
1	-----	1	DECAL, MODEL TW15 - S/N
2	2738332	2	DECAL, RED OBLONG REFLECTOR
3	00781352	1	SHEET, SINGLE SPINDLE SAFETY DECAL
3.1	D614	2	DECAL, DANGER THROWN OBJECT
3.2	D388	1	DECAL, DANGER PTO
3.3	00756004	1	DECAL, DANGER-SHIELD MISSING
4	00792241	1	SHEET, DECAL LOGO-TW15
4.1	D395	1	DECAL, WARNING-BLADE ATTACHMENT
4.2	00792190	2	DECAL, RHINO-BLACK 6" TALL
4.3	D137	1	DECAL, BLADE ROTATION CCW
4.4	00760657	1	DECAL, SAFETY WARNING
4.5	00792188	1	DECAL, TW15 MODEL
4.6	00792179	1	DECAL, RHINO-RED/WHITE/BLUE
4.7	00792180	1	DECAL, FLAG-MADE IN USA
4.8	D389-D814-D590	1	DECAL, DANGER/GREASE

TW15

# DEFLECTOR ASSEMBLY

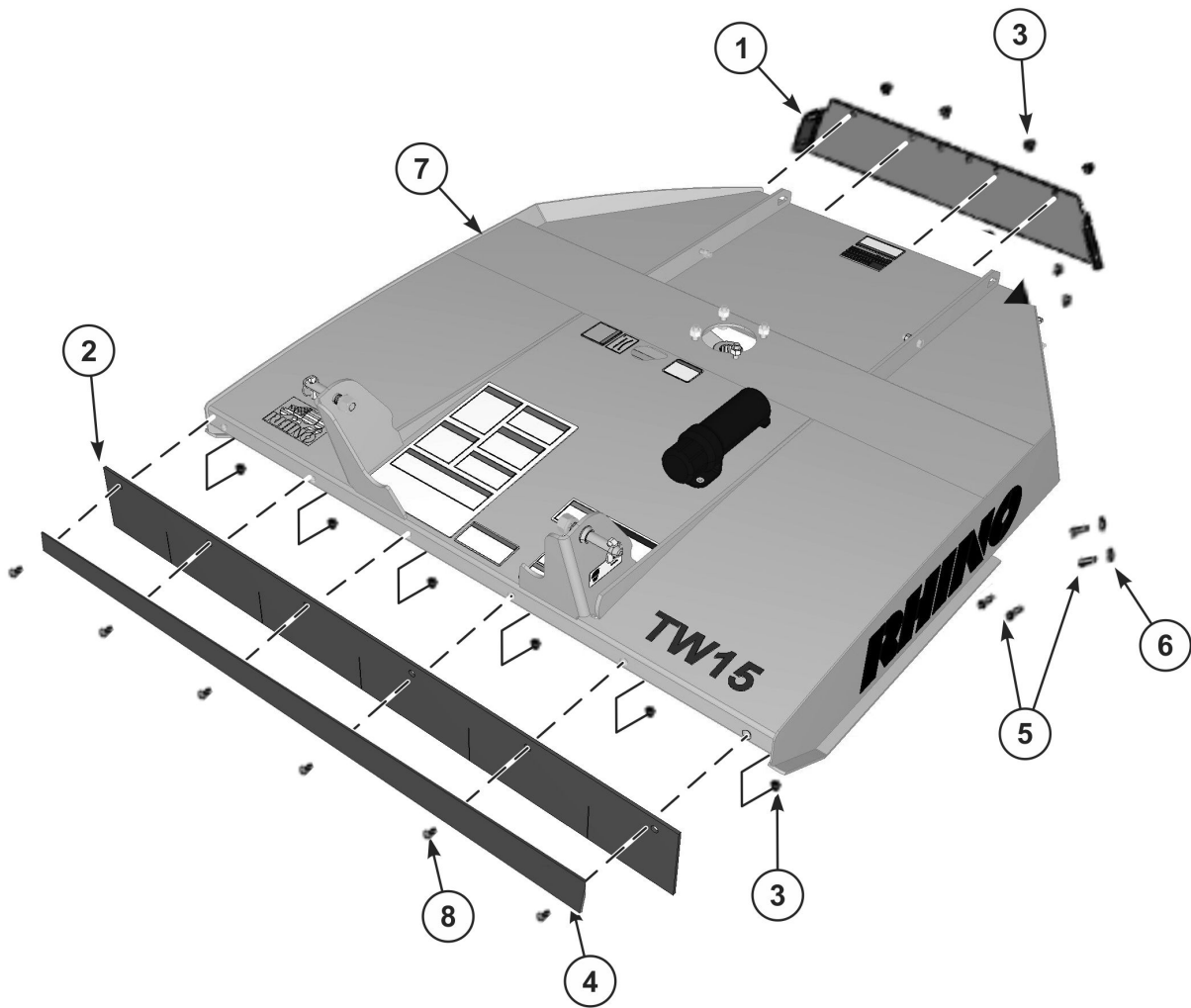

TW15

## DEFLECTOR ASSEMBLY

Continued...

ITEM	PART NO.	QTY.	DESCRIPTION
1	00792228	1	BAND, TW15 REAR
2	00792238	1	DEFLECTOR, RUBBER TW15 NUT,
3	4528	18	HEX LOCK 3/8-16 FLG WHIZ
4	00792175	1	FRONT DEFLECTOR STRAP - 5`
5	00011400	12	HEXB 3/8" NC X 1" PL5
6	00011100	4	FLATWASHER 3/8 PL STD WDMT,
7	00792210	1	DECK-TW15
8	26168	6	CRG-BLT 3/8 X 1 GR5

TW15

DRIVELINE ASSEMBLY - 00759318CSP CAT3 SLIP CLUTCH

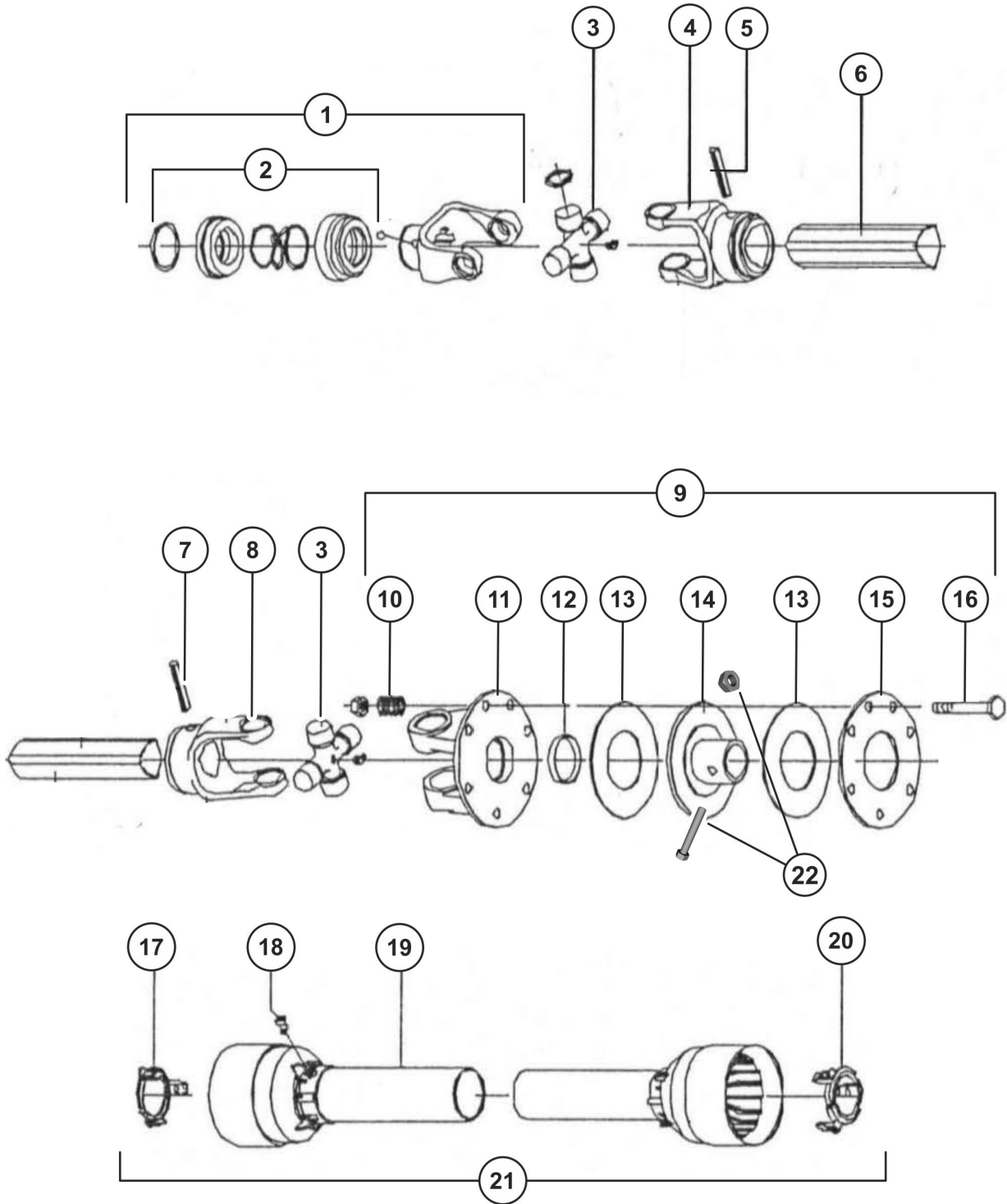



## DRIVELINE ASSEMBLY - 00759318CSP CAT3 SLIP CLUTCH

Continued...

ITEM	PART NO.	QTY.	DESCRIPTION
0	00759318CSP	1	COMPLETE DRIVELINE
1	00764500A	1	COMPLETE COLLAR YOKE
2	00774079	1	KIT COLLAR 1-3/8"
3	00756231	2	CROSS JOURNAL SET
4	00759168	1	OUTER YOKE
5	00759169	1	ROLL PIN FOR OUTER TUBE
6	00756004	1	DANGER LABEL FOR OUTER TUBE
7	00759165	1	ROLL PIN FOR INNER TUBE
8	00759164	1	INNER YOKE
9	00773087	1	COMPLETE DISC CLUTCH
10	00754303	8	SPRING
11	00773080	1	FLANGED YOKE
12	00773081	1	BUSH
13	00768347	2	LINING RING
14	00773082	1	CLUTCH SUPPORT F10
15	00773083	1	PRESSURE PLATE
16	00754316	8	BOLT & NUT M10X80
17	00764507	1	GUARD RETAINING COLLAR FOR INNER TUBE
18	00754330	6	BOLT
19	00756005	1	DANGER LABEL FOR OUTER GUARD TUBE
20	00764506	1	GUARD RETAINING COLLAR FOR OUTER TUBE
21	00768342	1	COMPLETE GUARD
22	00753013	1	BOLT 1/2 UNC X 3 GR8
	00001800	1	TOPLOCK NUT 1/2-13

TW15

DRIVELINE ASSEMBLY - 00789318SP CAT3 SHEAR BOLT

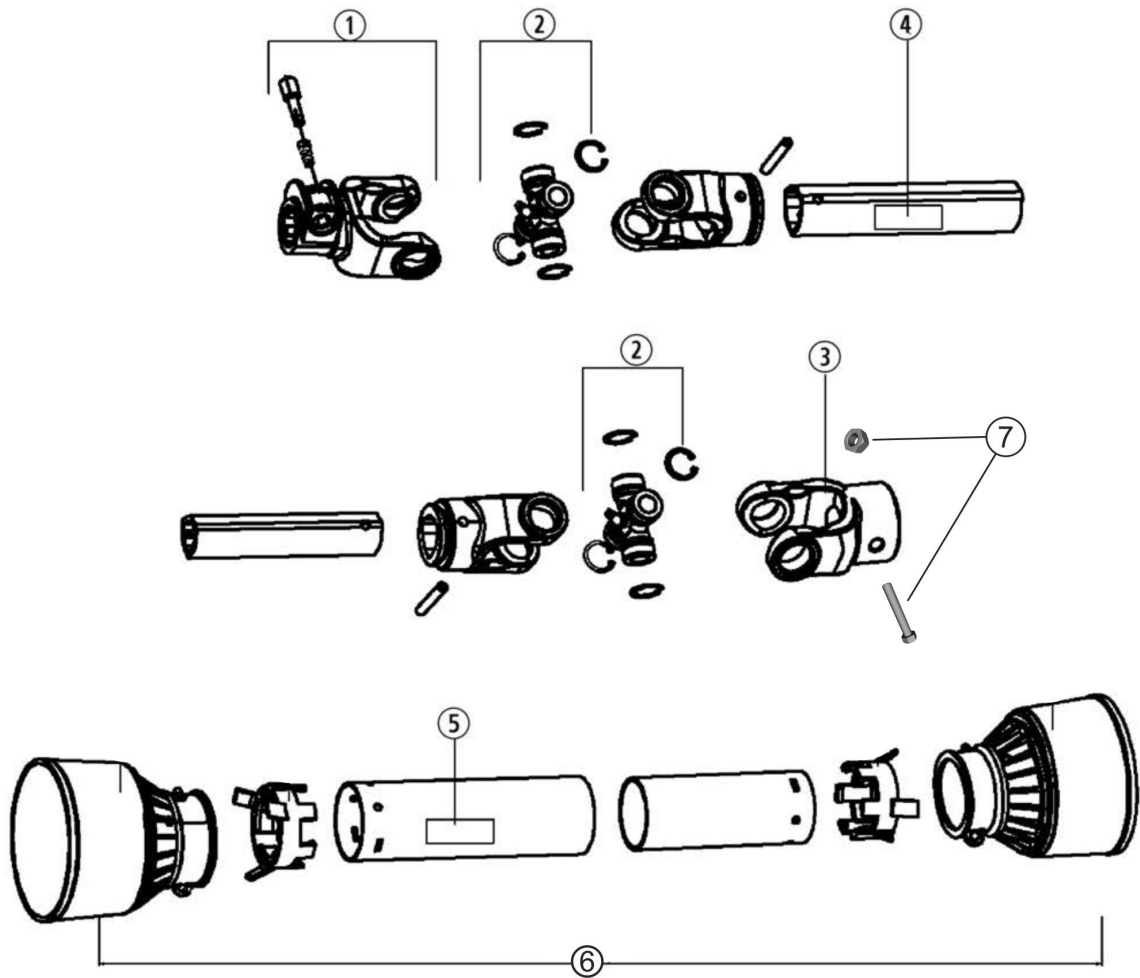

**DRIVELINE ASSEMBLY - 00789318SP CAT3 SHEAR BOLT**

**Continued...**

<b>ITEM</b>	<b>PART NO.</b>	<b>QTY.</b>	<b>DESCRIPTION</b>
	00789318	1	DRIVELINE ASSY.
1	00789317	1	PUSH PIN YOKE ASSY
2	00789306	2	CROSS BEARING KIT
3	00789316	1	YOKE, PLAIN BORE
4	00756004	1	SAFETY DECAL, INNER
5	00756005	1	SAFETY DECAL, OUTER
6	00789315	1	COMPLETE SHIELD KIT
7	314013C	1	BOLT, 1/2 UNC X 3 GR2
	00001800	1	NUT, TOPLOCK 1/2-13

GEARBOX ASSEMBLY - 50074339 540RPM

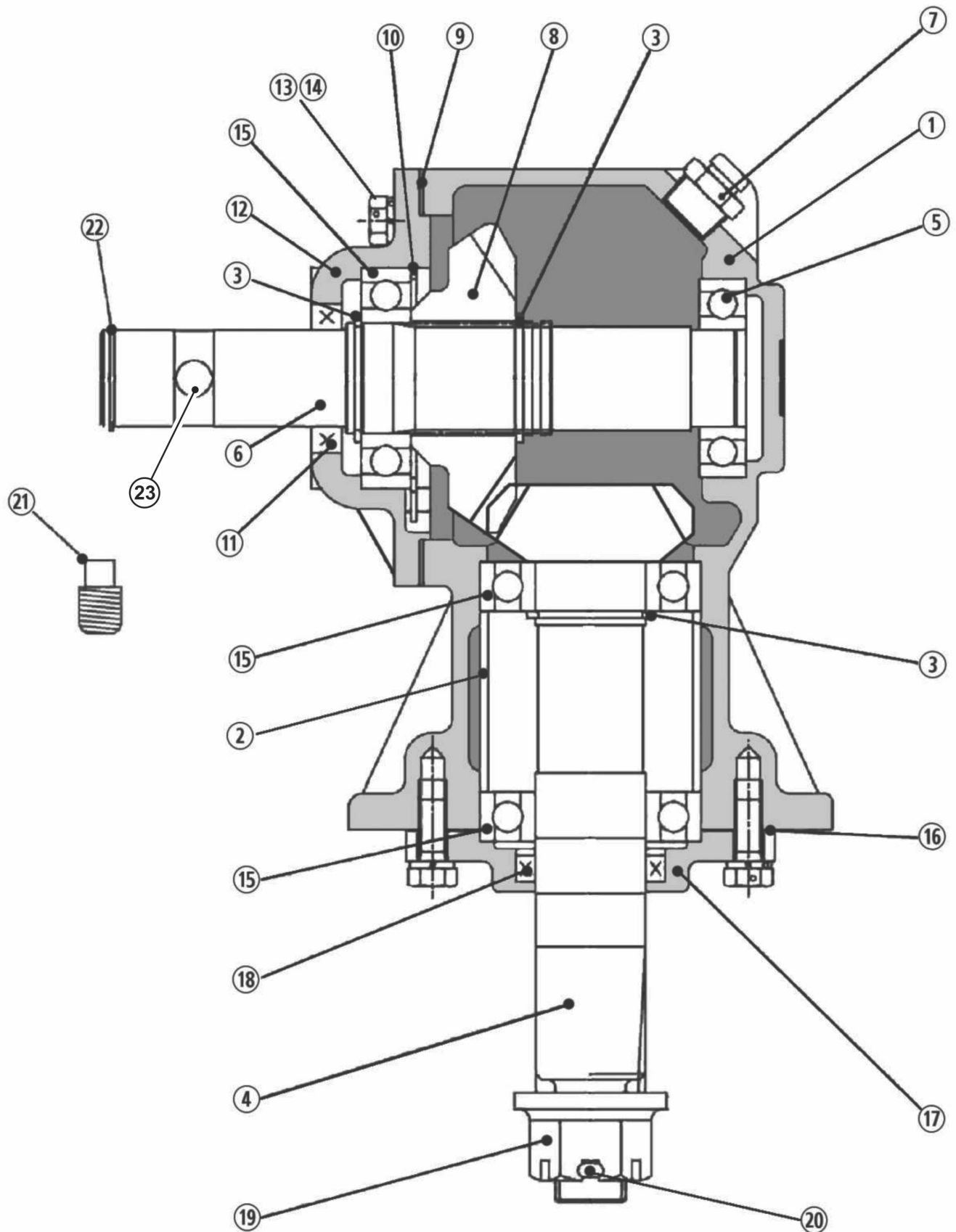

TW15

## GEARBOX ASSEMBLY - 50074339 540RPM

Continued...

ITEM	PART NO.	QTY.	DESCRIPTION
	50074339	1	GEARBOX ASSEMBLY
1	N/A	1	HOUSING
2	81630	1	SPACER
3	81631	3	RETAINING RING
4	50074340	1	PINION
5	70229	1	BEARING ASSY.
6	81634	1	SHAFT, INPUT
7	88851	1	PLUG, PRESSURE RELIEF
8	50074341	1	GEAR, INPUT
9	50052055	1	SHIM, .50MM
	50052053	1	SHIM, .15MM
	50052054	1	SHIM, .30MM
10	81637	1	RETAINING RING
11	88879	1	SEAL
12	50029491	1	CAP
13	20034	10	CAPSCREW 3/8" X 1" GR.5
14	15812	10	LOCKWASHER 3/8"
15	70256	3	BEARING ASSY.
16	50052058	1	SHIM, .50MM
	50052056	1	SHIM, .15MM
	50052057	1	SHIM, .30MM
17	81643	1	CAP
18	81644	1	SEAL
19	88873	1	HEX NUT, SLOTTED 1"
20	81648	1	COTTER PIN
21	69BH	1	PIPE PLUG
22	81445	1	SNAP RING, DRIVELINE RETAINER
23	00753013	1	BOLT 1/2 UNC X 3 GR8 (NOT SHOWN) - SLIPCLUTCH DRIVELINES ONLY
	00001800	1	TOPLOCK NUT 1/2-13 (NOT SHOWN) - SLIPCLUTCH AND SHEARBOLT DRIVELINES
	314013C	1	BOLT 1/2 UNC X 3 GR2 (NOT SHOWN) - SHEARBOLT DRIVELINE ONLY

GEARBOX ATTACHMENT

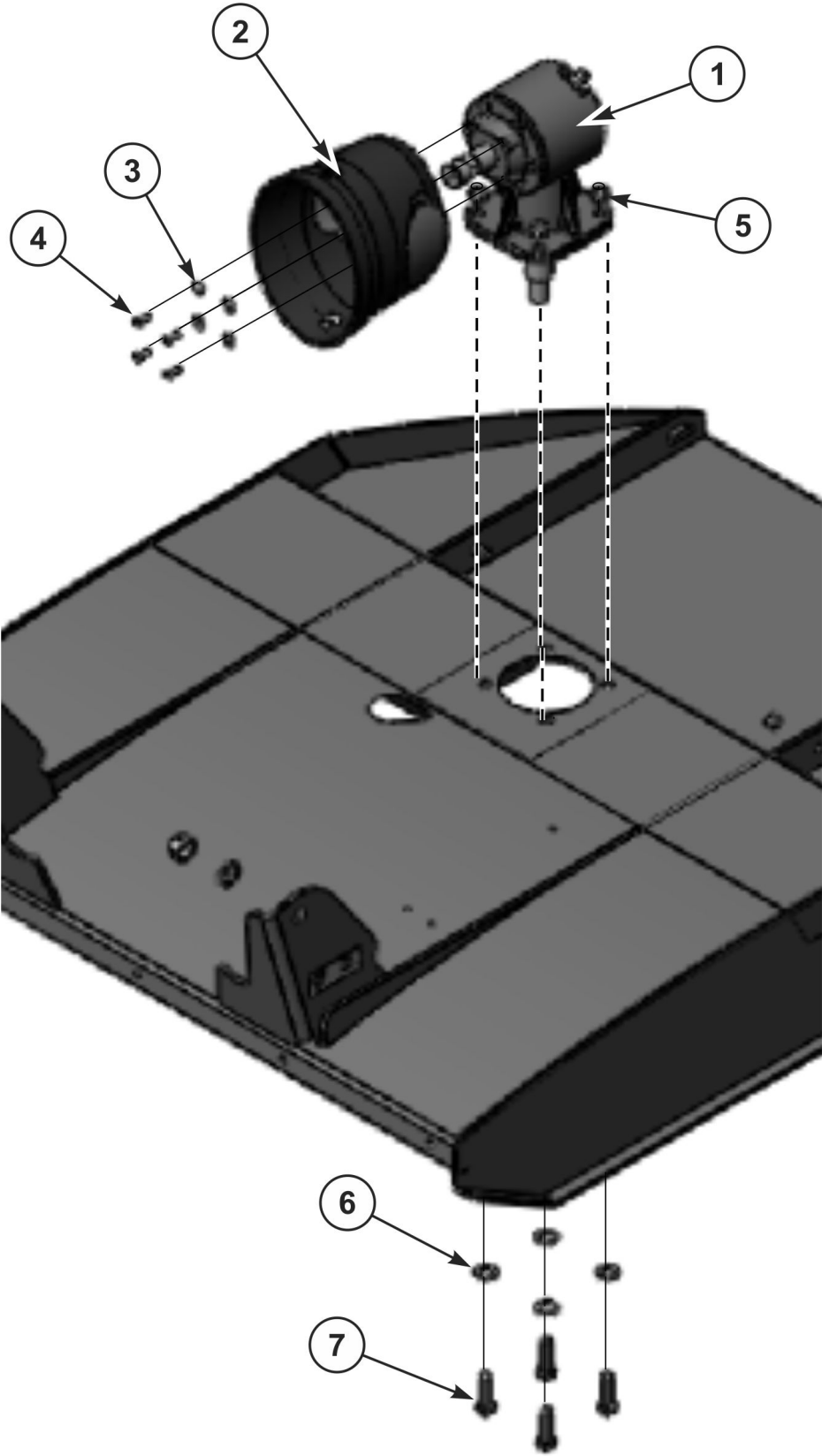

## GEARBOX ATTACHMENT

Continued...

ITEM	PART NO.	QTY.	DESCRIPTION
1	50074339	1	ASSY, GEARBOX
2	00785946	1	KIT/ GEARBOX SHIELD & RING
3	00023500	4	FLATWASHER, 5/16 PL
4	00035900	4	BOLT, HEX HD 5/16 X 3/4 GR5
5	00695100	4	NUT, TOPLOCK 5/8 NC PLC
6	00756077	4	WASHER, 5/8 HARDENED
7	02845500	4	HEXB, 5/8 NC X 2 PL5

# TAILWHEEL ASSEMBLY

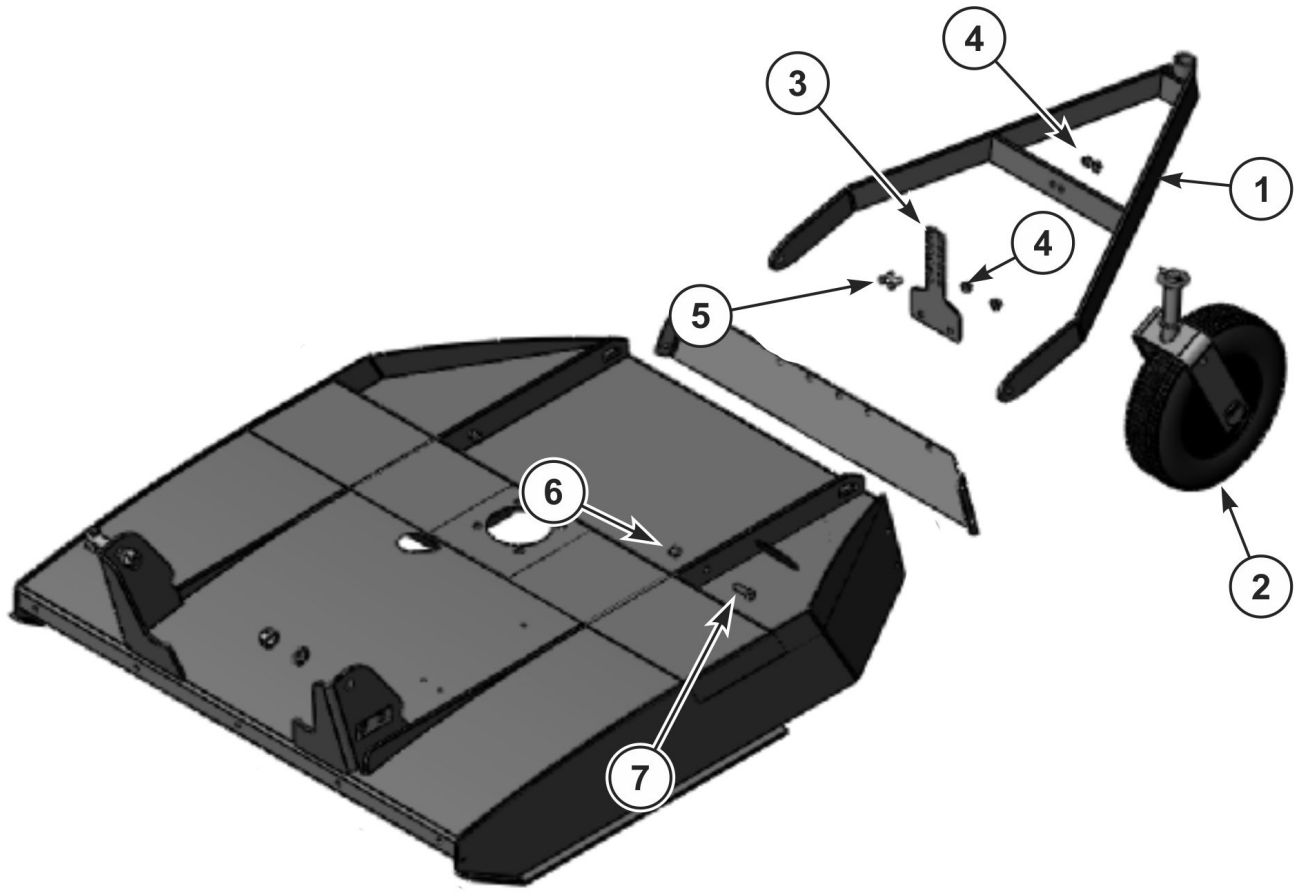





# SERVIS-RHINO

## LIMITED WARRANTY

### 1. LIMITED WARRANTIES

- 1.01. Servis-Rhino warrants for one year from the purchase date to the original non-commercial, governmental, or municipal purchaser ("Purchaser") and warrants for six months to the original commercial or industrial purchaser ("Purchaser") that the goods purchased are free from defects in material or workmanship.
- 1.02. Manufacturer will replace for the Purchaser any part or parts found, upon examination at one of its factories, to be defective under normal use and service due to defects in material or workmanship.
- 1.03. This limited warranty does not apply to any part of the goods which has been subjected to improper or abnormal use, negligence, alteration, modification, or accident, damaged due to lack of maintenance or use of wrong fuel, oil, or lubricants, or which has served its normal life. This limited warranty does not apply to any part of any internal combustion engine, or expendable items such as blades, shields, guards, or pneumatic tires except as specifically found in your Operator's Manual.
- 1.04. Except as provided herein, no employee, agent, Dealer, or other person is authorized to give any warranties of any nature on behalf of Manufacturer.

### 2. REMEDIES AND PROCEDURES.

- 2.01. This limited warranty is not effective unless the Purchaser returns the Registration and Warranty Form to Manufacturer within 30 days of purchase.
- 2.02. Purchaser claims must be made in writing to the Authorized Dealer ("Dealer") from whom Purchaser purchased the goods or an approved Authorized Dealer ("Dealer") within 30 days after Purchaser learns of the facts on which the claim is based.
- 2.03. Purchaser is responsible for returning the goods in question to the Dealer.
- 2.04. If after examining the goods and/or parts in question, Manufacturer finds them to be defective under normal use and service due to defects in material or workmanship, Manufacturer will:
  - (a) Repair or replace the defective goods or part(s) or
  - (b) Reimburse Purchaser for the cost of the part(s) and reasonable labor charges (as determined by Manufacturer) if Purchaser paid for the repair and/or replacement prior to the final determination of applicability of the warranty by Manufacturer.The choice of remedy shall belong to Manufacturer.
- 2.05. Purchaser is responsible for any labor charges exceeding a reasonable amount as determined by Manufacturer and for returning the goods to the Dealer, whether or not the claim is approved. Purchaser is responsible for the transportation cost for the goods or part(s) from the Dealer to the designated factory.

### 3. LIMITATION OF LIABILITY.

- 3.01. MANUFACTURER DISCLAIMS ANY EXPRESS (EXCEPT AS SET FORTH HEREIN) AND IMPLIED WARRANTIES WITH RESPECT TO THE GOODS INCLUDING, BUT NOT LIMITED TO, MERCHANTABILITY AND FITNESS FOR A PARTICULAR PURPOSE.
- 3.02. MANUFACTURER MAKES NO WARRANTY AS TO THE DESIGN, CAPABILITY, CAPACITY, OR SUITABILITY FOR USE OF THE GOODS.
- 3.03. EXCEPT AS PROVIDED HEREIN, MANUFACTURER SHALL HAVE NO LIABILITY OR RESPONSIBILITY TO PURCHASER OR ANY OTHER PERSON OR ENTITY WITH RESPECT TO ANY LIABILITY, LOSS, OR DAMAGE CAUSED OR ALLEGED TO BE CAUSED DIRECTLY OR INDIRECTLY BY THE GOODS INCLUDING, BUT NOT LIMITED TO, ANY INDIRECT, SPECIAL, CONSEQUENTIAL, OR INCIDENTAL DAMAGES RESULTING FROM THE USE OR OPERATION OF THE GOODS OR ANY BREACH OF THIS WARRANTY. NOT WITHSTANDING THE ABOVE LIMITATIONS AND WARRANTIES, MANUFACTURER'S LIABILITY HEREUNDER FOR DAMAGES INCURRED BY PURCHASER OR OTHERS SHALL NOT EXCEED THE PRICE OF THE GOODS.
- 3.04. NO ACTION ARISING OUT OF ANY CLAIMED BREACH OF THIS WARRANTY OR TRANSACTIONS UNDER THIS WARRANTY MAY BE BROUGHT MORE THAN TWO (2) YEARS AFTER THE CAUSE OF ACTION HAS OCCURRED.

### 4. MISCELLANEOUS.

- 4.01. Proper Venue for any lawsuits arising from or related to this limited warranty shall be only in Guadalupe County, Texas.
- 4.02. Manufacturer may waive compliance with any of the terms of this limited warranty, but no waiver of any terms shall be deemed to be a waiver of any other term.
- 4.03. If any provision of this limited warranty shall violate any applicable law and is held to be unenforceable, then the invalidity of such provision shall not invalidate any other provisions herein.
- 4.04. Applicable law may provide rights and benefits to purchaser in addition to those provided herein.

### KEEP FOR YOUR RECORDS

ATTENTION: Purchaser should fill in the blanks below for his reference when buying repair parts and/or for proper machine identification when applying for warranty.

Servis-Rhino Implement Model \_\_\_\_\_ Serial Number \_\_\_\_\_

Date Purchased \_\_\_\_\_ Dealer \_\_\_\_\_

ATTENTION:  
READ YOUR OPERATOR'S MANUAL

**RHINO**<sup>®</sup>  
1020 S. Sangamon Ave.  
Gibson City, IL 60936  
800-446-5158  
Email: parts@servis-rhino.com





## TO THE OWNER/OPERATOR/DEALER

To keep your implement running efficiently and safely, read your manual thoroughly and follow these directions and the Safety Messages in this Manual. The Table of Contents clearly identifies each section where you can easily find the information you need.

The OCCUPATIONAL SAFETY AND HEALTH ACT (1928.51 Subpart C) makes these minimum safety requirements of tractor operators:

### REQUIRED OF THE OWNER:

1. Provide a Roll-Over-Protective Structure that meets the requirements of this Standard; and
2. Provide Seatbelts that meet the requirements of this paragraph of this Standard and SAE J4C; and
3. Ensure that each employee uses such Seatbelt while the tractor is moving; and
4. Ensure that each employee tightens the Seatbelt sufficiently to confine the employee to the protected area provided by the ROPS.

### REQUIRED OF THE OPERATOR

1. Securely fasten seatbelt if the tractor has a ROPS.
  2. Where possible, avoid operating the tractor near ditches, embankments, and holes.
  3. Reduce speed when turning, crossing slopes, and on rough, slick, or muddy surfaces.
  4. Stay off slopes too steep for safe operation.
  5. Watch where you are going - especially at row ends, on roads, and around trees.
  6. Do not permit others to ride.
  7. Operate the tractor smoothly - no jerky turns, starts, or stops.
  8. Hitch only to the drawbar and hitch points recommended by the tractor manufacturer.
  9. When the tractor is stopped, set brakes securely and use park lock, if available.
-

